

LINHA PESADA



MB BRASMECK
juntas

MB BRASMECK
juntas

TECNOLOGIA ORIGINAL EM PEÇAS DE REPOSIÇÃO

PERFIL

Desde a sua fundação, ocorrida no ano de 1.988, a **BRASMECK Juntas Automotiva Indústria e Comércio Ltda.** procurou incessantemente trazer seu modelo de tecnologia para os mais diferentes tipos de automóveis e veículos automotivos de carga, com um conceito mais amplo e diversificado na fabricação de juntas de vedação. Pela total observância aos padrões de qualidade mundialmente reconhecido, o mercado automobilístico tornou-se nosso alvo.

Nosso Know-How está presente nos mercados interno e externo, traduzindo a mais pura forma de prestígio e tradição com que nossos clientes sempre nos distinguiu e definindo-se assim, uma acertada tomada de decisão na aquisição dos produtos Brasmeck, adicionando mais um fator para garantia de nossa competência e confiabilidade.

Acreditamos que essa preferência tenha sido fruto de nossa dedicação, o que nos estimula ainda mais a continuar a pesquisa em busca da perfeição. Pois a Nossa Missão é **"Contribuir para Vedação e Transporte de Fluídos nos Motores Automotivos"**.

Na nossa parceria, temos condições de oferecer vantagens diferenciadas por um custo competitivo.

"Assim cresceremos juntos".

MATÉRIA PRIMA

- NA - NÃO AMIANTO AUTOMOTIVO**
- GE - GAXETA NÃO AMIANTO**
- AL - ALUMÍNIO**
- BBS - BRASBESTO**
- BO - BORRACHA NITRÍLICA**
- BO+CH - BORRACHA + CHAPA**
- BOG - BORRACHA NITRÍLICA GRAFITADA**
- CB - CORTIÇA COM BORRACHA**
- CH - CHAPA**
- CU - COBRE**
- D.V.M. - DIVERSOS MATERIAIS**
- FBBSF - FLANDRES - BRASBESTO - FLANDRES**
- FI - FIBRA**
- GV - GUARNITAL VERDE**
- PE - PAPEL ESPECIAL**
- PP - POLIPROPILENO**
- PS - PRESSPHAN VERMELHO**

ÍNDICE

CHEVROLET BRASIL

Jogos de Motores	pág.
Chevrolet Brasil - Motor 261 / C10 / C20 / C60	1

CUMMINS

Jogos de Motores	pág.
Cummins 4B / BT	3
Cummins 6B/BT / 6BTA	5
Cummins 6C/CT / 6CTA	7

Jogos de Motores parte Inferior	pág.
Cummins 4B / BT	9
Cummins 6B/BT / 6BTA	11
Cummins 6C/CT / 6CTA	13

Jogos de Retificação de Válvulas	pág.
Cummins 4B / BT	14
Cummins 6B/BT / 6BTA	15
Cummins 6C/CT / 6CTA	16

FORD

Jogos de Motores	pág.
Ford F-2000 / F-4000	17
Ford Cargo Fase I	19
Ford Cargo Fase I	21

MERCEDES BENZ

Jogos de Motores	pág.
OM 314/L608 D Brasileiro (72/...) 4 Cilindros	23
OM 364 (87/...) Aspirado - 4 Cilindros	25
OM 364 (87/...) Turbinado - 4 Cilindros	27
OM 352 (70/...) Aspirado - 6 Cilindros	29
OM 352 Turbinado (81/...) - 6 Cilindros	31
OM 355 (85/...) - 5 Cilindros	33
OM 355 (85/...) - 6 Cilindros	35
OM 366 Aspirado (87/...) - 6 Cilindros	37
OM 366A Turbinado (87/...) - 6 Cilindros	39
BR 400 - 5 Cilindros - Motor 449	41
BR 400 - 6 Cilindros - Motor 447	43
OM 457 Eletrônico - 6 Cilindros	45

Jogos de Retificação de Válvulas	pág.
OM 314 (72/...) 4 Cilindros	47
OM 364 (87/...) Aspirado / Turbinado 4 Cilindros	48
OM 352 (70/...) Aspirado / Turbinado 6 Cilindros	49
OM 355 (85/...) - 5 Cilindros	50
OM 355 (85/...) - 6 Cilindros	51
OM 366 (87/...) Aspirado / Turbinado 6 Cilindros	52
BR 400 - Motor 449 / 447	53
OM 457 Eletrônico	54

Jogos de Juntas do Câmbio	pág.
ZF 16S 130/160/190 - MBB 1929/1932/1933/1934/1938/ 1941/LS 1632/LS 1938	55
OM-364 / OM-314 / 608-D 72 ED - CX. G-20 / 24	55
MBB 709 / 710 - CX. G-20 / 24	56
ZF-OH 1620 (Ônibus) OF 1620 (Caminhão)	56
OM-321 / 352 / 352A - Cx. - G3/36 - G40/60	57
OM-352 / 352A / 2013 / 2213 / 2218 (Antiga)	57
LP 321 / OM-352 / 352 A / OM-326 / OM-355/6Cils / OM-366/ 366 A Caminhões e Ônibus	58
ZF S-5 6.80 MBB OF-1620 / 1318 / L-1620 / OH-1421 / OH-1318 / 1418	59
OM-366 / VG-500 (moderna)	59
G3-55 (Veicular) MBB 1214 / 1218 / 1414 / 1614 / 1618 / 1714 /	

1718 / LK-1620 / 1718K / 1218	60
ZF S6-820 MBB LK 1123 / 1723 / Volvo Ônibus B-7	60
OM-326 / 352 / 321 Ônibus	61
ZF-S 6-90 / OM-370 / Volvo B-58	61
ZF-S 6-80 / MBB 1519 / 2219 / 1520 / 2220(Caminhões)	62
ZF 4K 120/121 - OM-355/6 - 1924 / 1924 A / 1524 / 1525	63

Jogos de Juntas do Compressor de Ar .

Jogos de Juntas do Compressor de Ar	pág.
Compressor OM-355 - Warco	64
Compressor de Ar Wabco OM-355	64
Compressor de Ar Motor 1114	64
Compressor de Ar MBB 352 / 352 A	65
Compressor OM-447 / 449	65
Compressor Wabco - MBB OM-366	66
Compressor de Ar Knorr LK 15 MBB OM-366 93/	66
Compressor de Ar OM-355	67
Compressor de Ar Knpr	67
Compressor de Ar LK - MBB OM-366	67
Compressor de Ar MBB OM-366	68
Compressor - LK 38	68

Jogos de Juntas da Turbina

Jogos de Juntas da Turbina	pág.
Turbina MB 804 / 814	69
Turbina Toyota	69
Turbina MBB OM-364 / 709 / 712	70
Turbina MBB OM-314 / 608-D	70
Turbina Toyota Motor OM-364	71
Turbina MBB 709	71
Turbina MBB OM-449/5	72
Turbina MBB OM-447/6	72
Turbina MBB OM-352 / 366 KKK Lacon / Garret	73
MBB OM-352 / 366 KKK Lacon / Garret	73

Jogos de Juntas Diversos

Jogos de Juntas Diversos	pág.
Radiador de Óleo MBB 709 / 701	74
Refrigeração de Óleo MBB OM-366 / 366 A	74
Cano D'Água MBB OM-366	74
Caixa de Direção MEC	75
Bomba D'Água MBB OM-352 A	75
Refrigeração de Óleo MBB OM-352 / 352 A	75
Refrigeração de Água MBB OM-314 / 352 / 352A / 364 / 366 / 366 A	76
Adaptação para Turbinamento OM-352	76
Adaptação para Turbinamento OM-366	76
Coletor de Admissão OM-355/5	77
Coletor de Admissão OM-355/6	77
Coletor de Escape OM-355/5	77
Coletor de Escape OM-355/6	78
Refrigeração de Água MBB OM-355/5/6	78

Juntas Diversas

Juntas do Diferencial

MWM

Jogos de Motores	pág.
MWM D-225 / 3 Cilindros	83
MWM D-225 / 4 Cilindros	85
MWM D-225 / 6 Cilindros	87
MWM D-226 / 4 Cilindros	89
MWM D-229 / 3 Cilindros	91
MWM D-229 / 4 Cilindros	93
MWM D-229 / 4 Cilindros Turbinado	95
MWM D-229 / 6 Cilindros	97
MWM D-229 / 6 Cilindros Turbinado	99
Motor 410-4 Série X-10 - Vans Volare	101
Motor 610-6 Série X-10	103
Sprint 4 Cilindros	105
Sprint 6 Cilindros	107

ÍNDICE

Jogos de Retificação de Válvulas pág.

MWM D-225	109
MWM D-226	110
MWM D-229	111
Motor 410-4 / 610-6 Série X-10 - Vans Volare	112
Sprint 4 Cilindros	113
Sprint 6 Cilindros	114

Jogos de Juntas de Câmbio pág.

Clark 450 5M - A-60 / F-1000 (85/91)	115
Câmbio Clark Caixa 280 V / VH / VHC / VHD 5M - A60 / C60 / D60 Caminhão VW D950 / P400 / DTI 400TD / 6.80 / 6.90 / 11.130 / 13.130	115
Câmbio Clark Caixa CL-450 / FS 4205 / 4205-A 5M - Caminhão VW 11.130 / 13.130	116
Câmbio Clark Caixa 280 V / VH / VHC / VHD 5M - A60 / C60 / D60 Caminhão VW D950 / P400 / DTI 400TD / 6.80 / 6.90 / 11.130 / 13.130	116
Câmbio Caixa Eaton 5106 / 5306/ 6005/ 6305 / 6206/6306 - 6M	117
Câmbio F-1000 - 4M	117
Câmbio F-4000 - 4M	118
Câmbio 240V - F-1000 - 5M	118
Câmbio 240V - F-4000 - 4/5M	119

Jogos de Juntas da Turbina pág.

Turbina Caminhão VW / MWM 229	120
Turbina TK - 107 S2A / F1000 / MWM	120
Turbina D-255 6 Cilindros (veicular / agrícola)	121
Turbina MWM X-10 4 Cilindros	121
Turbina MWM X-10 6 Cilindros	122
Turbina TK 107 / F1000 / F2000 / F4000 - Caminhão VW 4 Cilindros	122

Juntas Diversas pág.

PERKINS

Jogos de Motores pág.

Maxion HS 2.5	125
Perkins 3152 / 50X	127
Perkins 3152 Injeção Direta (Moderno)	129
Perkins 1006 / 1006 T Aspirado / Turbinado	131
Maxion 4.000 / 4.000T Agrícola	133
S4 / S4T (D20 / D40 / GMC 6.150 / 6.100 Plus) Aspirado / Turbinado	135
Perkins 4203 / 8BR Injeção Indireta	137
Perkins 4203 / MF 65 Injeção Indireta	139
Perkins 4203 / 65X - Injeção Direta	141
Perkins 4236 Turbo / MF 292	143
Perkins 4236 - D-10 / D-20 Veicular Injeção Direta	145
Perkins 4236 - Agrícola - Massey Ferguson	147
Perkins 4236 Q-20B	149
Perkins 4248 - Agrícola	151
Perkins Empilhadeira Yale	153
Perkins 6354.2	155
Perkins 6354.4	157
Perkins 6357-TA	159
Perkins 6357-V	161
Perkins 6358	163

Jogos de Retificação de Válvulas pág.

Maxion HS 2.5	165
Perkins 3152 / 50X	166
Perkins 3152 Injeção Direta	167
Perkins 1006 / 1006 T	168
Maxio S4 / S4T / 4.000 / 4.000T (Agrícola)	169
Perkins 4203 Injeção Indireta (MF 65 / BR)	170

Perkins 4203 - Injeção Direta 65X	171
Perkins 4236 Turbo / MF 292	172
Perkins 4236 Veicular / Agrícola / Q-20B	173
Perkins 4248	174
Perkins 6354.2	175
Perkins 6354.4	176
Perkins 6357- Veicular / Agrícola	177
Perkins 6358	178

SCANIA

Jogos de Motores pág.

L-75/76/110 - Motor Nacional Ônibus/Caminhão (63/76) ...	179
L-111 / L-112 Ônibus B-76 (76/89)	181
HW 112/113 - DN / DS / DSC11 (82/...)	183
HW 1990	185
Unificados 111/112 HW / 112/113 - DN / DS / DSC	187
LK 140 / 141/ - LKS 140	189
Scania DSC 124 - Motor 360	191

Jogos de Retificação de Válvulas pág.

L-75/76/110 - Motor Nacional Ônibus/Caminhão (63/76) ...	193
L-111 / L-112 Ônibus B-76 (76/89)	194
HW 112/113 - DN / DS / DSC11 (82/...)	195
Scania HW 1990	196
LK 140 / 141/ - LKS 140	197
Scania DSC 124 - Motor 360	198
Scania DSC 124 - Motor 420	199

Jogos de Juntas do Câmbio pág.

GR / GRS / RE 890 / 900 - 8 Marchas	200
GR 801 - 8 Marchas (Ônibus)	200
L-110 / 111 - LK 140 / 141 (Caminhão) Caixa GR 860 10 Marchas (com anéis)	201
B-111 / BR 112 / K 111 / K-S 112 (Ônibus)	202
B-75 / 76 (Ônibus)	202
Scania L-75	203
Scania L-75 (Caixa Reduzida)	203
Scania L-76 (Caixa Acoplada Moderna)	204
SC B-110/111-BR 115/116 (Ônibus Motor Dianteiro)	204
L-110 / 111 - LK 140 / 141 (Caminhão) Caixa GR 860 10 Marchas (sem anéis)	205

Jogos de Juntas do Compressor de Ar . pág.

Compressor de Ar Bendix TU-FLU 500	206
Compressor de Ar Bendix TU-FLU 700	206
Compressor Vargas 2 Cilindros	207
Compressor Vargas 2 Cilindros	207
Compressor Vargas 2 Cilindros	208

Jogos de Juntas da Turbina pág.

Turbina L-110 / 111 BR 116	209
Turbina T-112	209

Jogos de Juntas Diversos pág.

Escape. L-111/112 Ônibus B76	210
Coletor do Escape HW-112/113	210
Escape. LK 140/141	210
Coletor Admissão/Escape. LK-140/141 - LKS-140	211
Cano do Escape LK-140/141 - LKS-140	211
Escape. LK 140/141 - LKS-140	211
Admissão HW 112/113	212

Juntas Diversas pag.

Juntas Diversas 1	213
Juntas Diversas 2	215



TECNOLOGIA ORIGINAL EM PEÇAS DE REPOSIÇÃO



*CHEVROLET
BRASIL*



CHEVROLET BRASIL - MOTOR 261 / C10 / C20 / C60

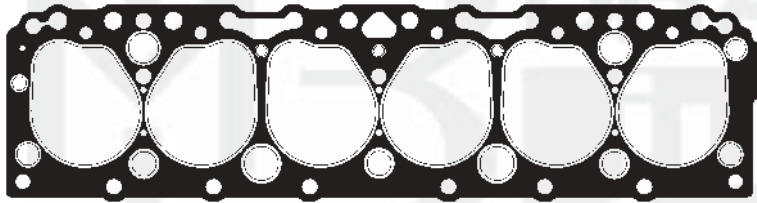

10.017-GAS



10.233-GV



10.263-GV



10 285-GV



10 288-CB



10 296-GV



10 303-CB



10 328-BBS



10 330-NA



10 334-NA



10 359-S



10 379-NA



10 383-BBS



10 408-NA



10 416-CB



10 417-GV



10 418-CB



10 463-NA



10 568-NA



ARRUELA

DESENHOS FORA DE ESCALA



TECNOLOGIA ORIGINAL EM PEÇAS DE REPOSIÇÃO



CUMMINS



CUMMINS 4B / BT



83.126-OIL



83.032-BBS



83.038-CB



83.039-BBS



83.070-BBS

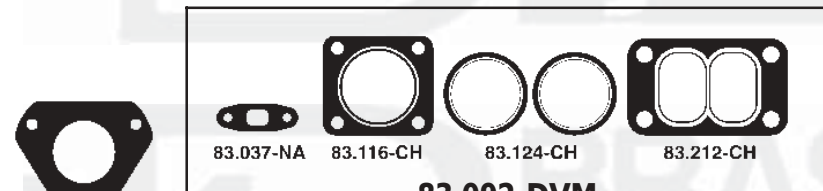

83.037-NA

83.116-CH

83.124-CH

83.212-CH

83.092-DVM

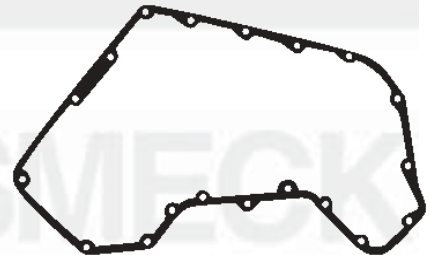

83.095-BBS



83.083-NA



83.096-BBS



83.097-NA



83.098-NA



83.102-BO



83.104-CH



83.107-NA



83.108-NA



83.109-BBS



83.113-BO

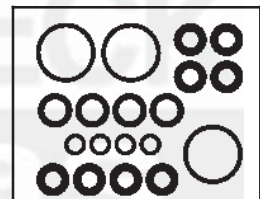

83.115-KA



83.117-KA

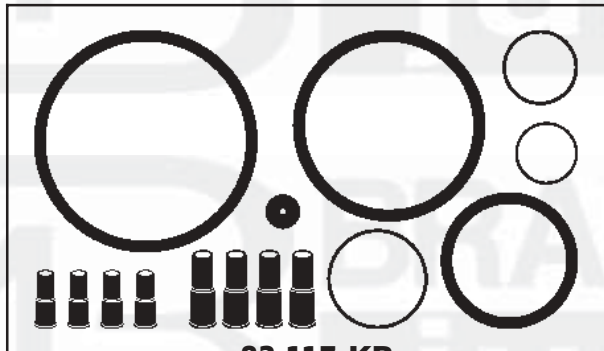

83.117-KB



83.118-BBS

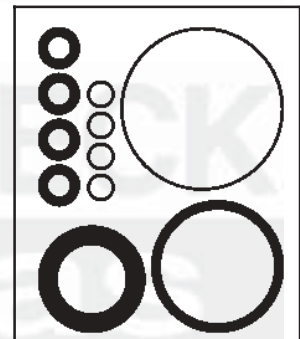

83.120-KB

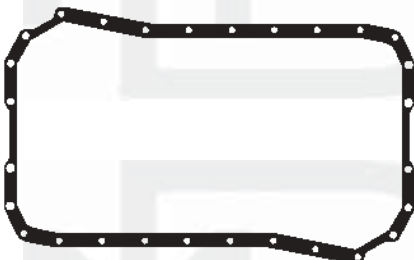

83.129-NA



83.130-NA



83.145-BBS



83.156-BO



83.175-NA



83.131-BO



83.250-S



83.251-S



83.252-S

DESENHOS FORA DE ESCALA

CUMMINS 6B/BT / 6BTA



83.105-OIL



83.032-BBS



83.038-CB



83.070-BBS



83.072-NA



83.083-NA

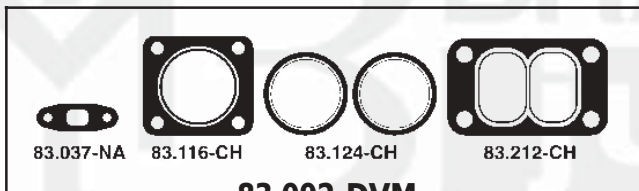

83.092-DVM



83.094-BBS

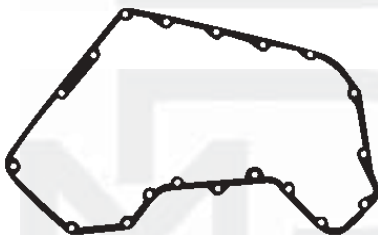

83.095-BBS



83.096-BBS



83.097-NA



83.098-NA



83.100-NA



83.102-BO



83.103-BO



83.104-CH



83.107-NA



83.108-NA



83.109-BBS



83.112-KB



83.110-BBS

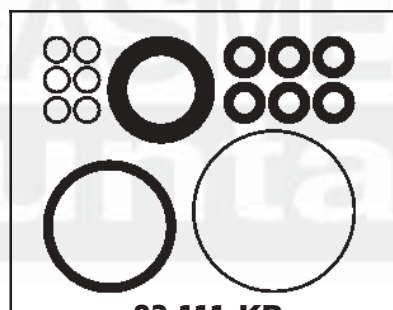

83.111-KB

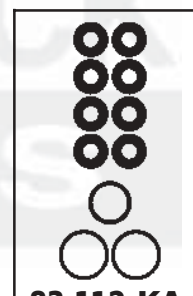

83.112-KA



83.118-BBS

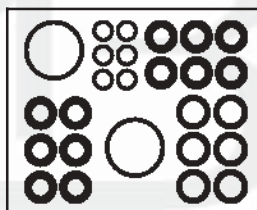

83.119-KA



83.113-BO



83.114-BO



83.131-BO



83.175-NA



83.250-S



83.251-S



83.252-S

DESENHOS FORA DE ESCALA

CUMMINS 6C/CT / 6CTA



83.081-OIL



83.030-NA



83.031-NA



83.032-BBS



83.033-BBS



83.036-CH



83.037-NA



83.039-BBS



83.040-BBS



83.042-BBS

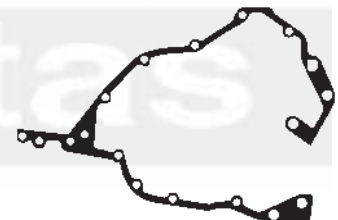

83.043-NA



83.057-NA



83.063-CH



83.064-NA



83.065-NA



83.066-NA



83.067-NA



83.071-BBS



83.073-NA



83.070-BBS



83.074-BO



83.075-CH



83.083-NA



83.084-NA



83.085-CH



83.086-NA

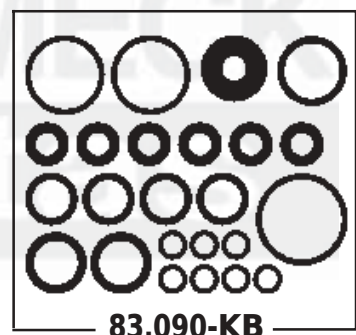

83.090-KB

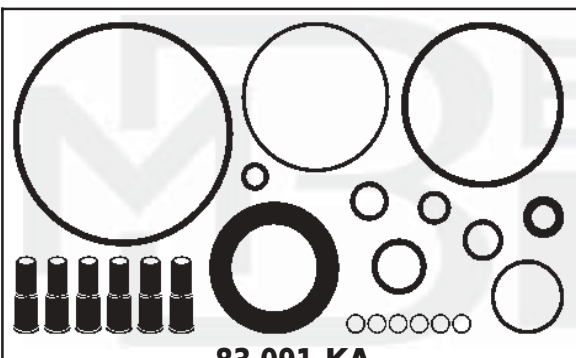

83.091-KA



83.101-BBS



83.102-BO



83.103-BO



83.251-S



83.253-S



83.254-S

DESENHOS FORA DE ESCALA

CUMMINS 6C/CT / 6CTA

CÓDIGO BRASMECK	CÓDIGO ORIGINAL	DESCRIÇÃO	QTDE.
83.206-CC		Jogo de Juntas do Motor Com Cabeçote Com Retenores	
		Modelos: Caminhões VW 16170 / 16220 / 35300 / 14220 / 16210 / 24250	
		Ford C1422 / 1622 / 2422 / 2425 / 3224 / 3530 / 4030	
83.206-CS		Jogo de Juntas do Motor Com Cabeçote Sem Retentor	
		Modelos: Caminhões VW 16170 / 16220 / 35300 / 14220 / 16210 / 24250	
		Ford C1422 / 1622 / 2422 / 2425 / 3224 / 3530 / 4030	
83.206-SC		Jogo de Juntas do Motor Sem Cabeçote Com Retentor	
		Modelos: Caminhões VW 16170 / 16220 / 35300 / 14220 / 16210 / 24250	
		Ford C1422 / 1622 / 2422 / 2425 / 3224 / 3530 / 4030	
83.206-SS		Jogo de Juntas do Motor Sem Cabeçote Sem Retentor	
		Modelos: Caminhões VW 16170 / 16220 / 35300 / 14220 / 16210 / 24250	
		Ford C1422 / 1622 / 2422 / 2425 / 3224 / 3530 / 4030	
83.081-OIL	3.935.585	Junta do Cabeçote	1
83.030-NA	3.914.311	Junta do Coletor de Admissão	1
83.031-NA	9.914.301	Junta da Tampa Traseira	1
83.032-BBS	3.916.042	Junta da BBA de Óleo	1
83.033-BBS	3.918.174	Junta Diversa	1
83.036-CH	3.929.012	Junta do Coletor de Escape	6
83.037-NA	3.931.350	Junta do Dreno de Óleo da Turbina	1
83.039-BBS	3.914.302	Junta do Cano do Respiro de Óleo	1
83.040-BBS	3.914.308	Junta do Filtro de Óleo	1
83.042-BBS	3.917.780	Junta da Tampa Frontal (moderna)	1
83.043-NA	3.929.253	Junta da Caixa de Distribuição	1
83.057-NA	3.934.044	Junta do Carter	1
83.063-CH		Junta de Vedação do Escape	2
83.064-NA	3.914.310	Junta do Termostato	1
83.065-NA		Junta do Adaptador da BBA	1
83.066-NA	3.918.340	Junta Diversa	1
83.067-NA	3.060.912	Junta da Conexão	1
83.070-BBS	3.931.348	Junta Diversa	1
83.071BBS	3.917.779	Junta da Tampa Frontal (antiga)	1
83.073-NA	3.921.440	Junta da Conexão de Admissão	1
83.074-BO	3.905.449	Junta da Tampa de Válvulas	1
83.075-CH	3.911.941	Junta da Saída do Escape	1
83.083-NA	3.931.607	Junta da BBA Injetora	1
83.084-NA	176.027	Junta do Suporte do Compressor de Ar	1
83.085-CH	3.575.909	Junta do Turbo	1
83.086-NA	3.931.350	Junta do Retorno de Óleo do Turbo	1
83.090-KB		Kit Borrachas	1
83.091-KA		Kit Arruelas	1
83.101-BBS	3.929.011	Junta do Filtro de Óleo (moderno)	1
83.102-BO	3.930.139	Borrifador da Saída do Pistão	6
83.103-BO	3.912.473	Anel de Borracha (155,97 x 162,17 x 7,00mm)	1
83.251-S	3.909.410	Retentor Traseiro do Virabrequim	1
83.253-S	3.353.977	Retentor Dianteiro do Virabrequim	1
83.254-S	3915707/391903	Retentor de Haste de Válvulas	12

TODAS AS PEÇAS SÃO FORNECIDAS INDIVIDUALMENTE

CUMMINS 4B / BT



83.032-BBS



83.038-CB



83.039-BBS



83.070-BBS



83.083-NA

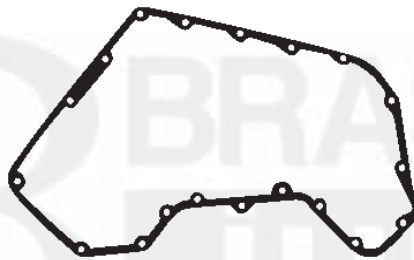

83.095-BBS

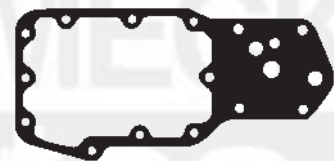

83.096-BBS



83.097-NA



83.098-NA



83.102-BO



83.107-NA



83.108-NA



83.109-BBS

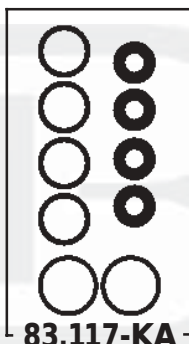

83.117-KA

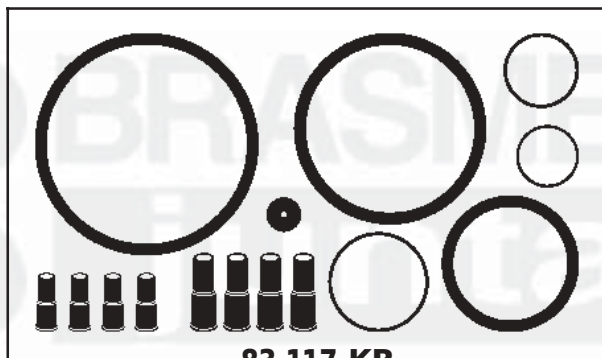

83.117-KB



83.118-BBS



83.129-NA



83.131-BO



83.250-S



83.251-S

CUMMINS 6B/BT / 6BTA



83.032-BBS



83.038-CB



83.070-BBS

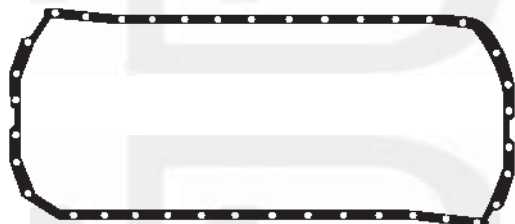

83.072-NA



83.083-NA



83.094-BBS

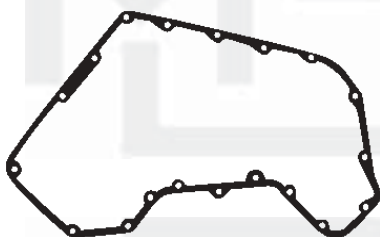

83.095-BBS

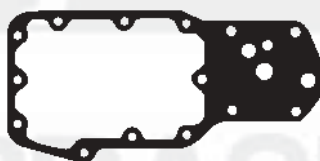

83.096-BBS



83.097-NA



83.098-NA



83.102-BO



83.103-BO



83.107-NA



83.108-NA



83.109-BBS



83.110-BBS

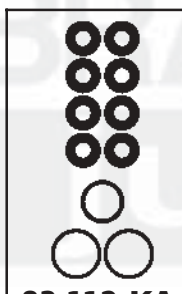

83.112-KA

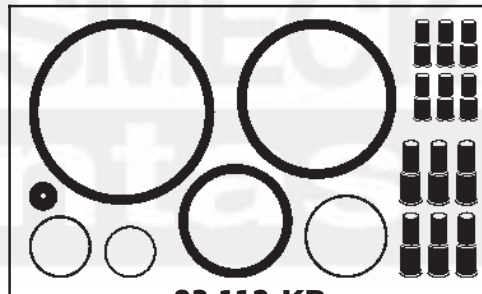

83.112-KB



83.114-BO



83.118-BBS



83.131-BO



83.250-S



83.251-S

DESENHOS FORA DE ESCALA

CUMMINS 6C/CT / 6CTA



83.031-NA



83.032-BBS



83.033-BBS



83.037-NA



83.039-BBS



83.040-BBS

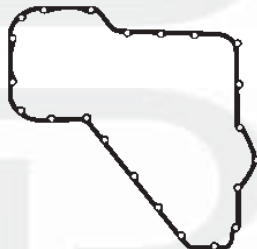

83.042-BBS



83.043-NA



83.057-NA



83.066-NA



83.070-BBS



83.071-BBS



83.083-NA



83.084-NA



83.103-BO



83.251-S

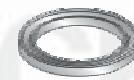

83.253-S

DESENHOS FORA DE ESCALA

CÓDIGO BRASMECK	CÓDIGO ORIGINAL	DESCRIÇÃO	QTDE.
83.247-I	3.357.004	Jogo de Juntas para Parte Inferior Com Retentor	
83.248-I	3.357.004	Jogo de Juntas para Parte Inferior Sem Retentor	
83.031-NA	9.914.301	Junta da Tampa Traseira	1
83.032-BBS	3.916.042	Junta da BBA de Óleo	1
83.033-BBS	3.918.174	Junta Diversa	1
83.037-NA	3.931.350	Junta do Dreno de Óleo da Turbina	1
83.039-BBS	3.914.302	Junta do Cano do Respiro de Óleo	1
83.040-BBS	3.914.308	Junta do Filtro de Óleo	1
83.042-BBS	3.917.780	Junta da Tampa Frontal (moderna)	1
83.043-NA	3.929.253	Junta da Caixa de Distribuição	1
83.057-NA	3.934.044	Junta do Carter	1
83.066-NA	3.918.340	Junta Diversa	1
83.070-BBS	3.931.348	Junta Diversa	1
83.071-BBS	3.917.779	Junta da Tampa Frontal (antiga)	1
83.083-NA	3.931.607	Junta da BBA Injetora	1
83.084-NA	176.027	Junta do Suporte do Compressor de Ar	1
83.103-BO	3.912.473	Anel de Borracha (155,97 x 162,17 x 7,00mm)	1
83.251-S	3.909.410	Retentor Traseiro do Virabrequim	1
83.253-S	3.353.977	Retentor Dianteiro do Virabrequim	1

TODAS AS PEÇAS SÃO FORNECIDAS INDIVIDUALMENTE

CUMMINS 4B/BT / 4BTA



83.126-OIL

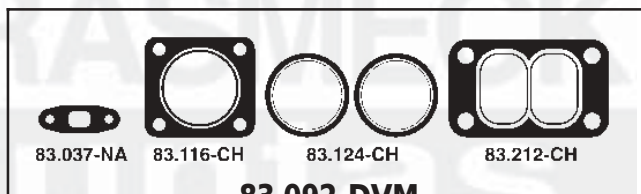

83.092-DVM



83.104-CH



83.113-BO

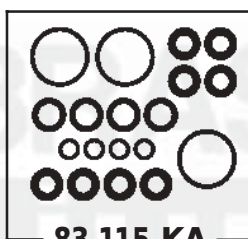

83.115-KA

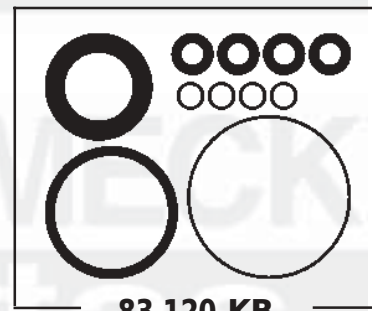

83.120-KB



83.130-NA



83.156-BO



83.252-S

DESENHOS FORA DE ESCALA

CÓDIGO BRASMECK	CÓDIGO ORIGINAL	DESCRIÇÃO	QTDE.
83.046-CC	3.804.096	Jogo de Juntas p/ Retificação de Válvulas C/ Cabeçote C/ Haste de Válvulas	
83.046-CS	3.804.096	Jogo de Juntas p/ Retificação de Válvulas C/ Cabeçote S/ Haste de Válvulas	
83.046-SC		Jogo de Juntas p/ Retificação de Válvulas S/ Cabeçote C/ Haste de Válvulas	
83.046-SS		Jogo de Juntas p/ Retificação de Válvulas S/ Cabeçote S/ Haste de Válvulas	
83.126-OIL	3.283.569	Junta do Cabeçote	1
83.092-DVM		Jogo de Juntas da Turbina	1
83.104-CH	3.927.154	Junta do Coletor do Escape	4
83.113-BO	3.902.666	Junta da Tampa de Válvulas	4
83.115-KA		Kit de Arruelas Superior	1
83.120-KB		Kit de Borrachas Superior	1
83.130-NA	3.931.605	Junta da Tampa do Coletor de Admissão	1
83.156-BO	3.283.767	Junta da Tampa Lateral	1
83.252-S	3.921.640	Retentor de Haste de Válvulas	8

TODAS AS PEÇAS SÃO FORNECIDAS INDIVIDUALMENTE

CUMMINS 6B/BT / 6BTA



83.105-OIL

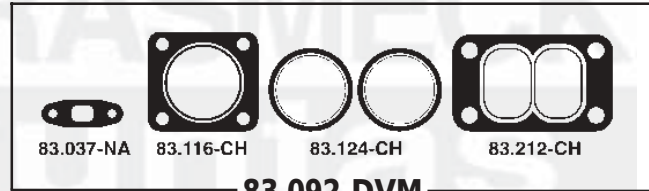

83.092-DVM



83.100-NA



83.104-NA

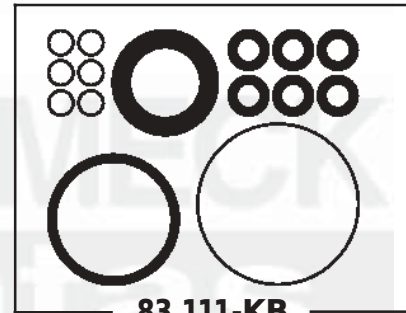

83.111-KB



83.113-BO

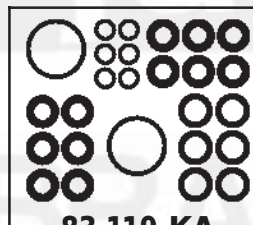

83.119-KA



83.252-S

DESENHOS FORA DE ESCALA

CÓDIGO BRASMECK	CÓDIGO ORIGINAL	DESCRIÇÃO	QTDE.
83.146-CC	3.804.096	Jogo de Juntas p/ Retificação de Válvulas C/ Cabeçote C/ Haste de Válvulas	
83.146-CS	3.804.096	Jogo de Juntas p/ Retificação de Válvulas C/ Cabeçote S/ Haste de Válvulas	
83.146-SC		Jogo de Juntas p/ Retificação de Válvulas S/ Cabeçote C/ Haste de Válvulas	
83.146-SS		Jogo de Juntas p/ Retificação de Válvulas S/ Cabeçote S/ Haste de Válvulas	
83.105-OIL	3.283.570	Junta do Cabeçote	1
83.092-DVM		Jogo de Juntas da Turbina	1
83.100-NA	3.931.347	Junta do Coletor de Admissão	1
83.104-CH	3.927.154	Junta do Coletor de Escape	6
83.111-KB		Kit de Borrachas Superior	1
83.113-BO	3.902.666	Junta da Tampa de Válvulas	6
83.119-KA		Kit de Arruelas Superior	1
83.252-S	3.921.640	Retentor de Haste de Válvulas	12

TODAS AS PEÇAS SÃO FORNECIDAS INDIVIDUALMENTE

CUMMINS 6C/CT / 6CTA



83.081-OIL



83.030-NA



83.036-CH



83.063-CH



83.064-NA



83.065-NA



83.067-NA



83.073-NA



83.074-BO



83.085-CH



83.086-NA

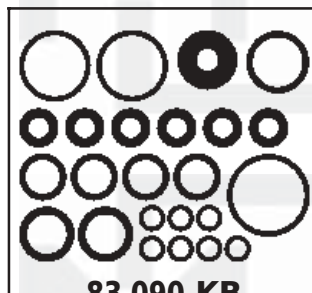

83.090-KB

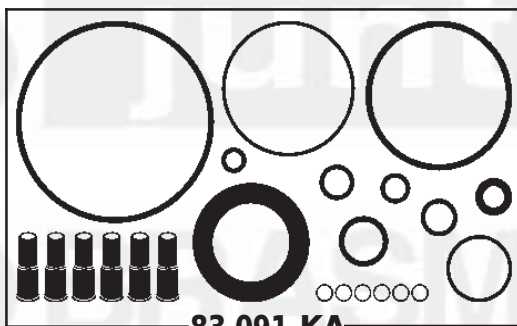

83.091-KA



83.254-S

DESENHOS FORA DE ESCALA

CÓDIGO BRASMECK	CÓDIGO ORIGINAL	DESCRIÇÃO	QTDE.
83.246-CC		Jogo de Juntas p/ Retificação de Válvulas C/ Cabeçote C/ Haste de Válvulas	
83.246-CS		Jogo de Juntas p/ Retificação de Válvulas C/ Cabeçote S/ Haste de Válvulas	
83.246-SC		Jogo de Juntas p/ Retificação de Válvulas S/ Cabeçote C/ Haste de Válvulas	
83.246-SS		Jogo de Juntas p/ Retificação de Válvulas S/ Cabeçote S/ Haste de Válvulas	
83.081-OIL	3.935.585	Junta do Cabeçote	1
83.030-NA	3.914.311	Junta do Coletor de Admissão	1
83.036-CH	3.929.012	Junta do Coletor de Escape	6
83.063-CH		Junta de Vedação do Escape	2
83.064-NA	3.914.310	Junta do Termostato	1
83.065-NA		Junta do Adaptador da BBA	1
83.067-NA	3.060.912	Junta da Conexão	1
83.073-NA	3.921.440	Junta da Conexão de Admissão	1
83.074-BO	3.905.449	Junta da Tampa de Válvulas	1
83.085-CH	3.575.909	Junta do Turbo	1
83.086-NA	3.931.350	Junta do Retorno de Óleo do Turbo	1
83.090-KB		Kit Borrachas	1
83.091-KA		Kit Arruelas	1
83.254-S	3915707/391903	Retentor de Haste de Válvulas	12

TODAS AS PEÇAS SÃO FORNECIDAS INDIVIDUALMENTE



TECNOLOGIA ORIGINAL EM PEÇAS DE REPOSIÇÃO



FORD F-2000 / F-4000



61.501-OIL

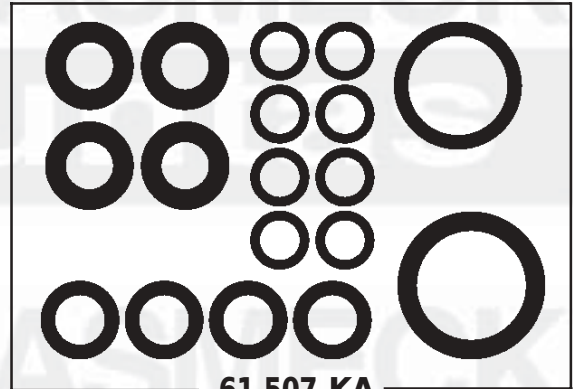

61.507-KA

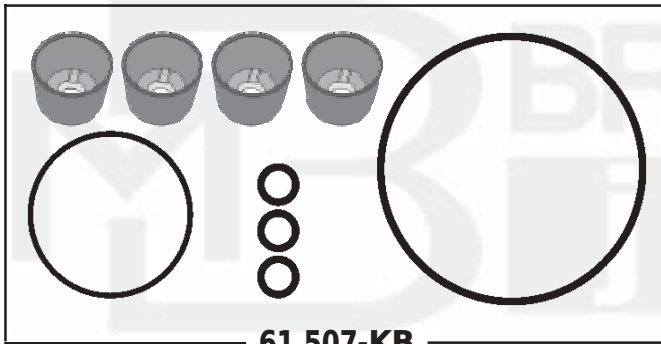

61.507-KB

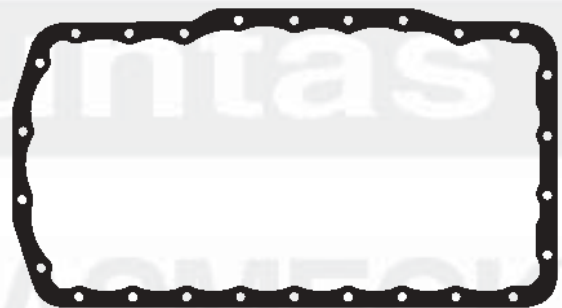

61.517-CB



61.521-BBS



61.523-NA



61.524-NA



61.526-CB



61.527-NA



61.528-NA



61.529-NA



61.530-NA



61.532-NA



61.533-NA



61.534-NA



61.535-NA



61.536-NA



61.537-GV



61.538-NA



61.539-CB



61.542-BO



61.646-CB

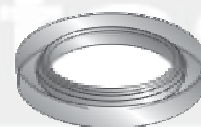

9.2511-S



9.2449-S

DESENHOS FORA DE ESCALA

FORD CARGO FASE I

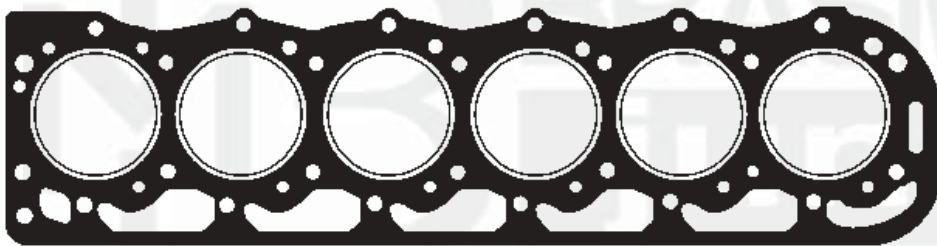

61.601-OIL



48.373-CH



61.321-BBS



61.528-NA



61.529-NA



61.531-CB



61.533-NA



61.542-BO

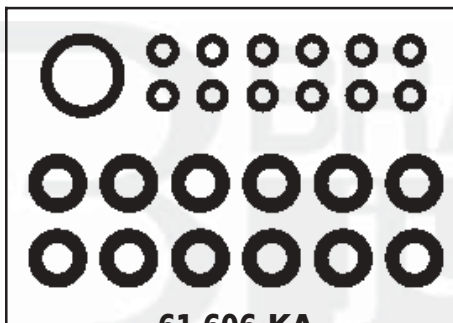

61.606-KA

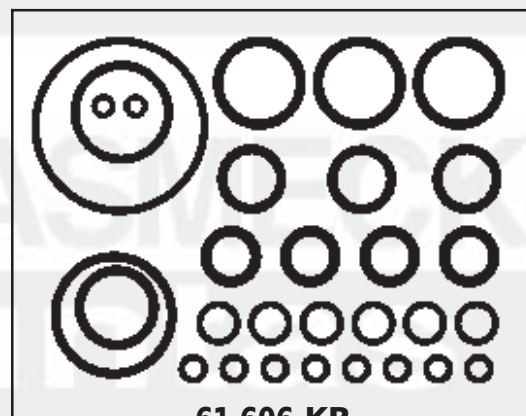

61.606-KB



61.616-CB



61.622-NA



61.626-CB

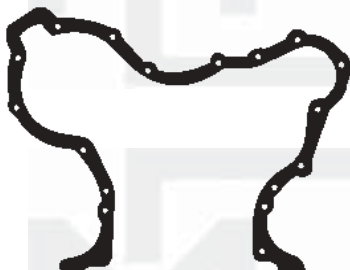

61.628-NA

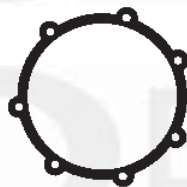

61.630-CB



61.632-PS



61.633-NA



61.634-NA



61.640-NA



61.646-CB



61.675-NA



61.676-NA



9.2511-S



9.2449-S

DESENHOS FORA DE ESCALA

FORD CARGO FASE II

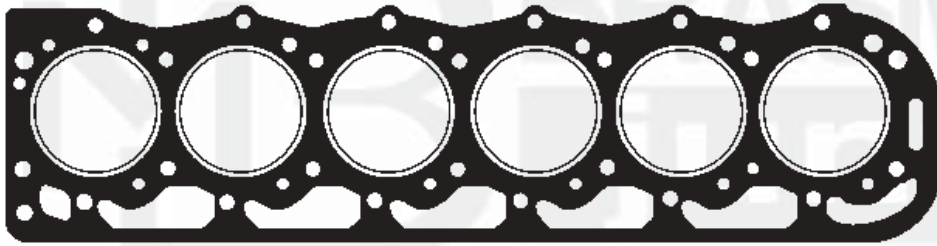

61.601-OIL



61.528-NA



61.542-BO

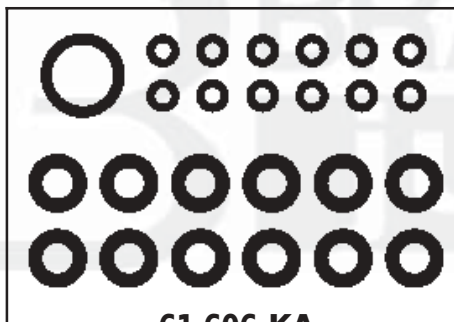

61.606-KA

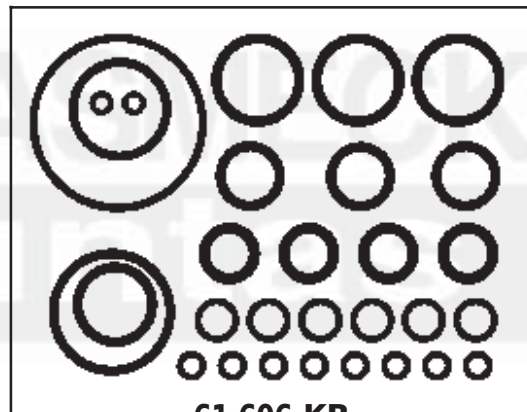

61.606-KB



61.616-CB



61.623-NA



61.624-BBS



61.626-CB



61.629-NA



61.630-CB

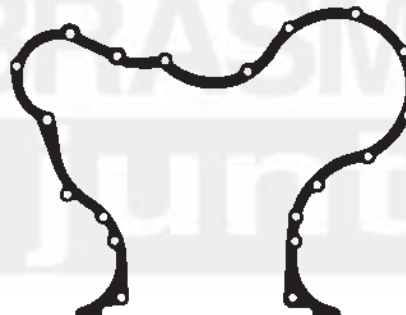

61.631-NA



61.632-PS



61.633-NA



61.634-NA



61.640-NA



61.646-CB



61.671-CH



61.675-NA



61.676-NA

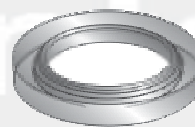

9.2511-S



9.2449-S

DESENHOS FORA DE ESCALA



TECNOLOGIA ORIGINAL EM PEÇAS DE REPOSIÇÃO



*MERCEDES
BENZ*



OM 314/L608 D Brasileiro (72/...) 4 Cilindros

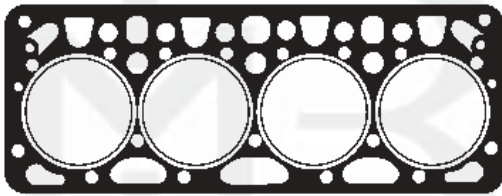

48.301-OIL



48.127-CB



48.129-NA



48.136-NA

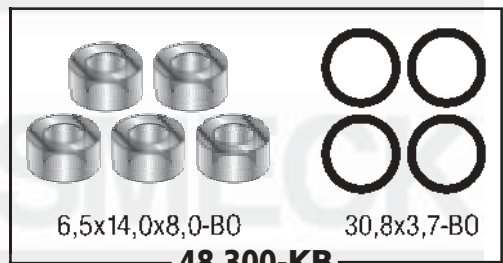
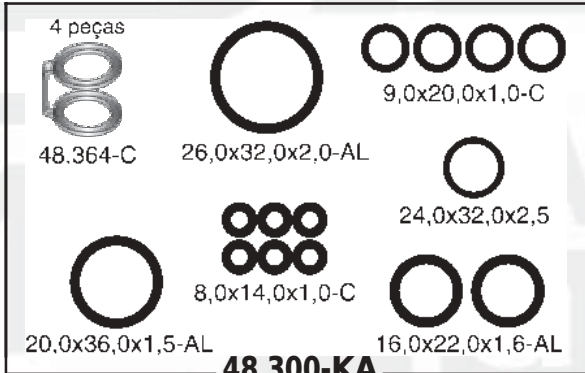

48.321-BBS



48.316-CBL



48.326-CBL



48.328-CBL



48.330-NA

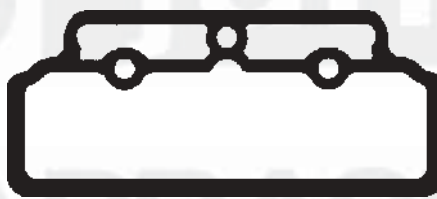

48.332-BBS



48.333-CBL



48.335-NA



48.337-NA



48.338-NA



48.340-BBS



48.341-NA



48.342-NA



48.344-NA



48.346-NA



48.347-NA



48.448-NA



48.834-NA



48.838-NA



48.849-NA



48.850-NA



48.891-NA

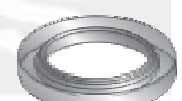

9.1810-S

DESENHOS FORA DE ESCALA

OM 364 (87/...) Aspirado - 4 Cilindros

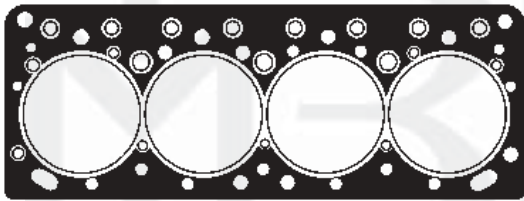

48.305-OIL



48.042-BBS



48.129-NA



48.136-NA



48.221-CH



48.222-BBS

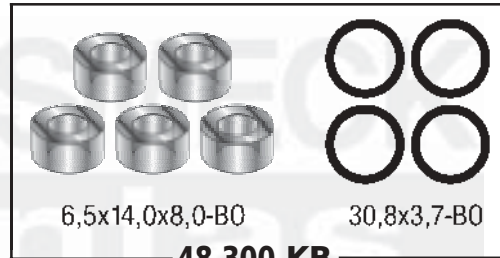
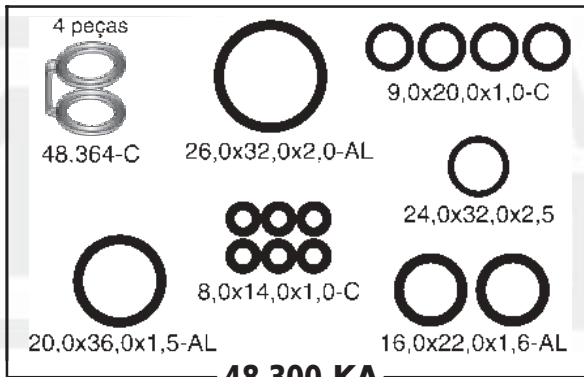

48.325-B0



48.316-CBL



48.326-NA



48.328-CBL



48.330-NA



48.335-NA



48.337-NA



48.339-NA



48.341-NA



48.342-NA



48.344-NA



48.426-BBS



48.435-NA



48.446-NA



48.448-NA



48.534-NA



48.834-NA



48.850-NA



48.875-BBS

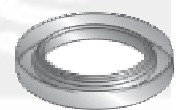

9.1810-S

DESENHOS FORA DE ESCALA

OM 364 (87/...) Turbinado - 4 Cilindros

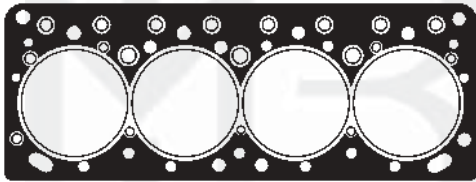

48.305-OIL



48.042-BBS



48.129-NA



48.136-NA



48.221-CH



48.222-BBS

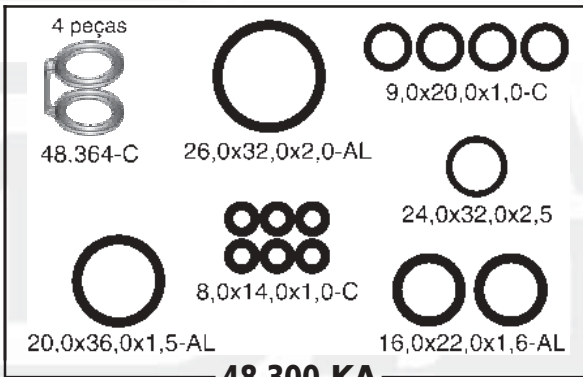

48.300-KA

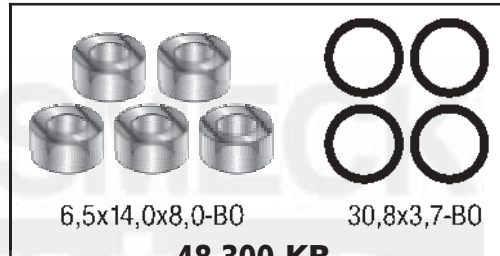

48.300-KB

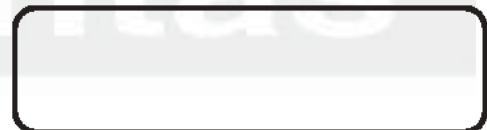

48.325-BO



48.316-CBL



48.330-NA



48.326-NA



48.328-CBL



48.335-NA



48.337-NA



48.339-NA



48.341-NA



48.342-NA



48.344-NA



48.426-BBS



48.435-NA



48.446-NA



48.448-NA



48.534-NA



48.834-NA

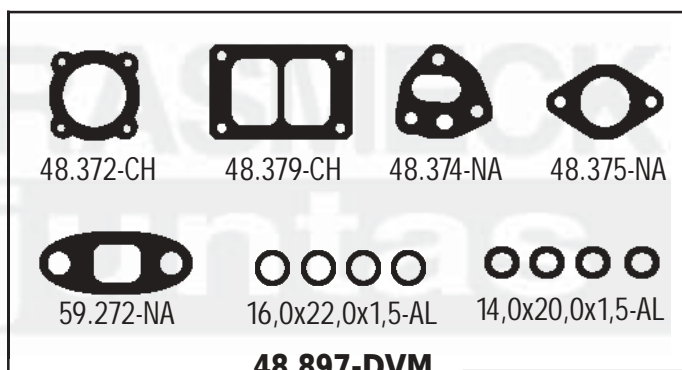

48.897-DVM



48.850-NA



48.875-BBS



9.1810-S

DESENHOS FORA DE ESCALA

OM-352 (70/...) Aspirado 6 Cilindros

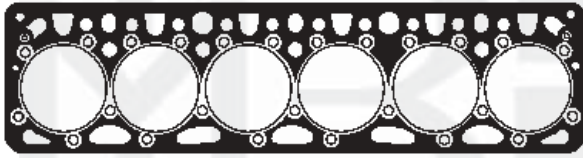

48.802-OIL



48.042-BBS



48.129-NA



48.136-NA



48.341-NA



48.140-CHA



48.326-CBL



48.328-CBL



48.333-CBL



48.337-NA



48.342-NA



48.344-NA



48.346-NA



48.347-NA



48.448-NA



48.527-CB



48.534-NA

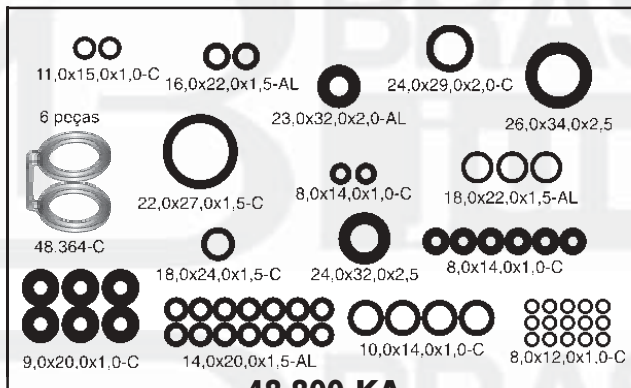

48.800-KA

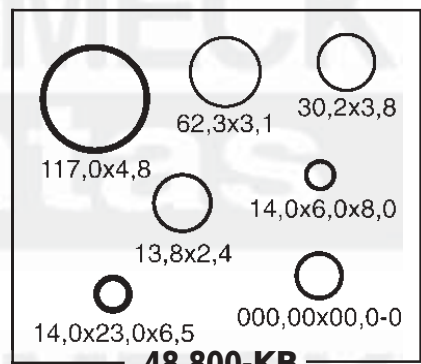

48.800-KB



48.816-CBL



48.822-CH

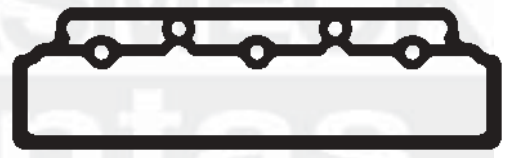

48.832-BBS



48.834-NA



48.835-NA



48.838-NA



48.849-NA



48.850-NA



48.531-PS

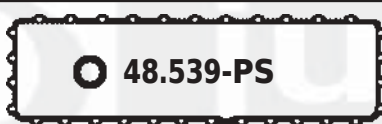

48.530-PS

48.868-PS

48.539-PS



48.875-BBS

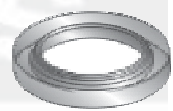

9.1810-S

DESENHOS FORA DE ESCALA

OM 352 Turbinado (81/...) 6 Cilindros

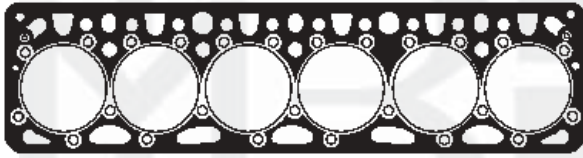

48.802-OIL



48.042-BBS



48.129-NA



48.136-NA



48.326-CBL



48.328-CBL



48.333-CBL



48.337-NA



48.341-NA



48.342-NA



48.344-NA



48.346-NA



48.347-NA



48.448-NA



48.527-CB



48.534-NA

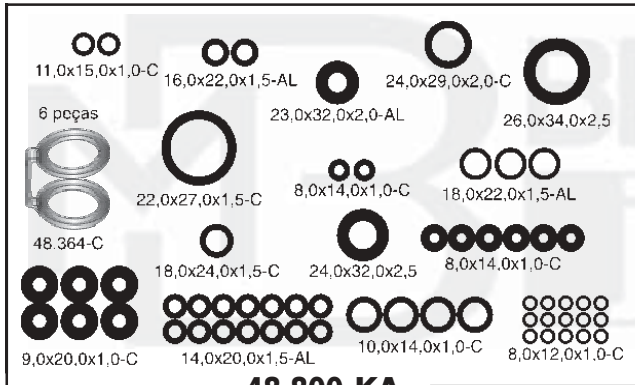

48.800-KA



48.800-KB



48.816-CBL



48.822-CH



48.832-BBS



48.834-NA



48.835-NA



48.838-NA



48.849-NA



48.850-NA



48.875-BBS



48.372-CH



48.379-CH



48.374-AA



48.375-AA



59272-AA



16,0x22,0x1,5-AL



14,0x20,0x1,5-AL

48.897-DVM



48.539-PS

48.530-PS



48.531-PS

48.868-PS



48.893-NA



48.931-CHA



9.1810-S

DESENHOS FORA DE ESCALA

OM 355 (85/...) - 5 Cilindros

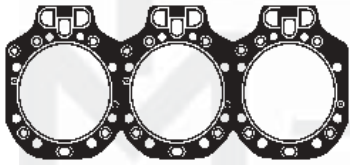

48.901-OIL

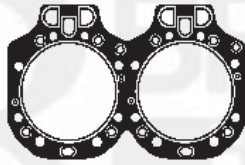

48.902-OIL

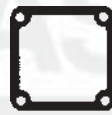

48.263-NA



48.264-NA



48.265-BBS

48.260-DVM



48.333-CBL

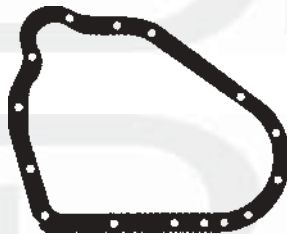

48.729-CBL



48.746-NA



48.772-NA



26,57x3,53-BO



18,77x1,78-BO



60,8x4,3-BO



23,47x2,95-BO



30,8x3,7-BO

48.900-KB



30,0x36,0x2,0-AL



30,0x36,0x2,0-C



27,0x33,0x2,0-C



24,0x29,0x2,0-AL



20,0x25,0x1,5-C



20,0x24,0x1,5-C

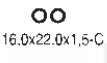

16,0x22,0x1,5-C



18,0x22,0x1,5-C



12,0x16,0x1,5-F



14,0x20,0x1,5-C



48.364-C



22,0x27,0x1,5-C

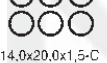

9,0x20,0x1,0-C



8,0x12,0x1,0-C

48.909-KA

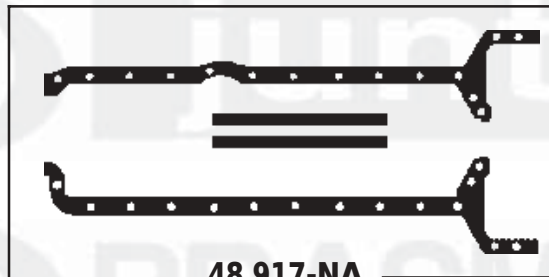

48.917-NA



48.920-BBS



48.921-CH



48.922-BBS



48.926-BBS



48.927-NA



48.931-CHA

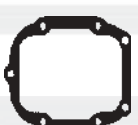

48.937-NA



48.938-NA



48.939-NA



48.940-NA



48.941-NA



48.942-NA



48.943-NA



48.945-NA



48.946-NA



48.948-NA



48.949-NA



48.949-NA



48.956-BBS



48.957-NA



48.958-NA



48.959-NA



48.966-NA



48.962-NA



48.976-BO



48.987-BO



59.263-CH



59.264-NA



59.265-NA



59.777-CH

59.260-DVM



9.0269-S



9.1815-S



9.7013-S

DESENHOS FORA DE ESCALA

OM 355 (85/...) - 5 Cilindros

CÓDIGO BRASMECK	CÓDIGO ORIGINAL	DESCRIÇÃO	QTDE.
48.909-CC	345.586.0290	Jogo de Juntas Motor Com Cabeçote Com Retentor Modelos OF 370 / 371 / 1524L / 1525LK / 1924L / 1925LK 1932L / 1933LK / FAM	
48.909-CS		Jogo de Juntas Motor Com Cabeçote Sem Retentor Modelos OF 370 / 371 / 1524L / 1525LK / 1924L / 1925LK 1932L / 1933LK / FAM	
48.909-SS		Jogo de Juntas Motor Sem Cabeçote Sem Retentor Modelos OF 370 / 371 / 1524L / 1525LK / 1924L / 1925LK 1932L / 1933LK / FAM	
48.901-OIL	355.016.0220	Junta do Cabeçote – 3 cilindros	1
48.902-OIL	345.016.0020	Junta do Cabeçote – 2 cilindros	1
48.260-DVM	000.130.9320	Jogo de Juntas do Compressor de Ar	1
48.333-CBL	312.018.0180	Junta da Tampa da Tubulação do Óleo	1
48.729-CBL	346.015.0120	Junta da Distribuição	1
48.746-NA	065.181.0079	Junta da Flange BBA de Óleo	1
48.772-NA	071.151.102.6001	Junta da BBA de Óleo	2
48.900-KB		Kit de Borrachas	1
48.909-KA		Kit de Arruelas	1
48.917-NA	345.586.7001	Jogo de Juntas do Carter	1
48.920-BBS	345.141.0080	Junta do Coletor de Admissão	1
48.921-CH	345.142.7060	Junta do Coletor de Escape.	5
48.922-BBS	346.141.0180	Junta do Coletor de Admissão	1
48.926-BBS	346.016.0221	Junta da Tampa de Válvulas	5
48.927-NA	355.015.0022	Junta da Tampa Lateral das Válvulas	1
48.931-CHA	344.492.0080	Junta da Saída do Escape	1
48.937-NA	355.188.0080	Junta da BBA de Óleo	1
48.938-NA	355.184.0480	Junta do Filtro do Óleo ao Bloco	1
48.939-NA	326.997.0149	Junta do Cavalete da BBA D'Água	5
48.940-NA	355.201.0080	Junta do Arrefecimento do Motor	2
48.941-NA	355.203.0080	Junta da Válvula Termostática ao Bloco	1
48.942-NA	346.077.0380	Junta do Regulador da BBA Injetora	2
48.943-NA	356.201.0180	Junta da BBA D'Água	1
48.945-NA	327.075.0180	Junta da Vedação Corpo do Mancal	1
48.946-NA	346.018.0080	Junta do Bocal do Enchimento de Óleo	1
48.948-NA	000.131.1479	Junta do Compressor	1
48.949-NA	000.131.1679	Jogo de Juntas do Compressor de Ar	1
48.956-BBS	000.131.4380	Junta do Cabeçote Compressor de Ar	1
48.957-NA	345.015.0022	Junta da Lateral do Motor	1
48.958-NA	303.018.0079	Junta da Vareta do Óleo	1
48.959-NA	07.151.104.0017	Junta do Tubo de Ventilação	1
48.962-NA	345.015.0021	Junta da Tampa Lateral do Motor	1
48.966-NA		Junta do Refrigerador de Óleo	2
48.976-BO	355.201.0178	Anel de Borracha	1
48.987-BO		Borracha da Admissão	5
59.260-DVM		Jogo de Juntas da Turbina (Somente para Jogo Turbinado)	1
9.0269-S	004.997.3947	Retentor Virabrequim Dianteiro	1
9.1815-S	352.053.0269	Retentor Haste de Válvulas	20
9.7013-S	315.030.0080	Retentor do Volante	1

TODAS AS PEÇAS SÃO FORNECIDAS INDIVIDUALMENTE

OM 355 (85/...) - 6 Cilindros

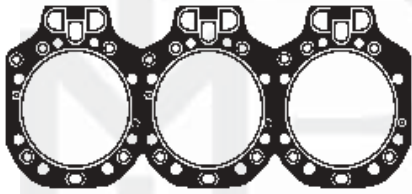

48.901-OIL

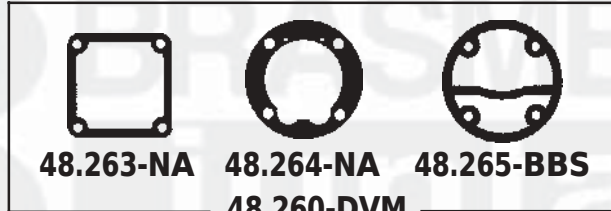

48.263-NA

48.264-NA

48.265-BBS

48.260-DVM



48.333-CBL



48.716-NA



48.729-CBL



48.746-NA



48.772-NA

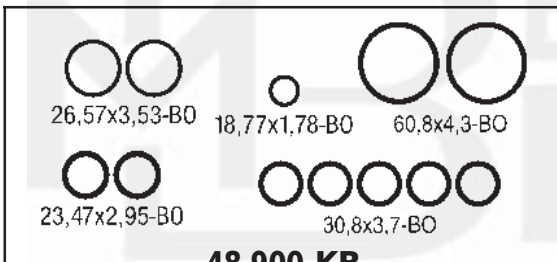

48.900-KB



26,57x3,53-BO

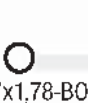

18,77x1,78-BO

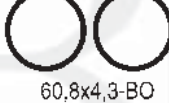

60,8x4,3-BO



23,47x2,95-BO



30,8x3,7-BO

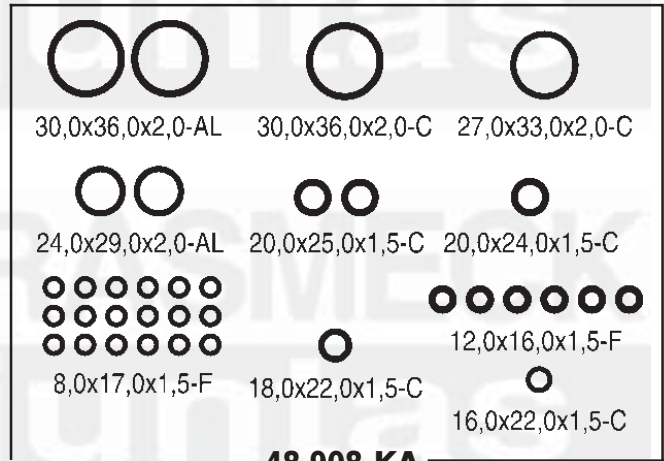

48.908-KA



30,0x36,0x2,0-AL



30,0x36,0x2,0-C



27,0x33,0x2,0-C

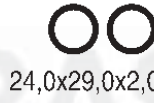

24,0x29,0x2,0-AL



20,0x25,0x1,5-C



20,0x24,0x1,5-C



8,0x17,0x1,5-F



18,0x22,0x1,5-C



12,0x16,0x1,5-F

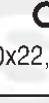

16,0x22,0x1,5-C



48.921-CH



48.922-BBS



48.926-BBS



48.927-NA



48.928-NA



48.931-CHA



48.937-NA



48.938-NA



48.939-NA



48.940-NA



48.941-NA



48.942-NA



48.943-NA



48.945-NA



48.946-NA



48.948-NA

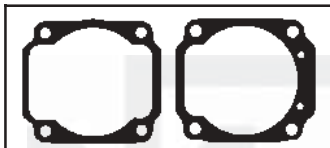

48.949-NA



48.958-NA



48.959-NA



48.966-NA



48.976-BO



48.987-BO



59.263-CH

59.264-NA

59.265-NA

59.777-CH

59.260-DVM



9.0269-S



9.1815-S



9.7013-S

OM-355 (85/...) 6 Cilindros

CÓDIGO BRASMECK	CÓDIGO ORIGINAL	DESCRIÇÃO	QTDE.
48.908-CC	345.586.0390	Jogo de Juntas Motor Com Cabeçote Com Retentor - Modelos OF O370/371 / 1524L / 1525LK / 1525LK / 1924L / 1925LK / 1932L / 1933LK / FAM	
48.908-CS		Jogo de Juntas Motor Com Cabeçote Sem Retentor - Modelos OF O370/371 / 1524L / 1525LK / 1525LK / 1924L / 1925LK / 1932L / 1933LK / FAM	
48.908-SS		Jogo de Juntas Motor Sem Cabeçote Sem Retentor - Modelos OF O370/371 / 1524L / 1525LK / 1525LK / 1924L / 1925LK / 1932L / 1933LK / FAM	
48.901-OIL	355.016.0220	Junta do Cabeçote – 3 cilindros	2
48.260-DVM	000.130.9320	Jogo de Juntas do Compressor de Ar	1
48.333-CBL	312.018.0180	Junta da Tampa da Tubulação do Óleo	1
48.716-NA	355.586.0001	Jogo de Juntas do Carter	1
48.729-CBL	346.015.0120	Junta da Distribuição	1
48.746-NA	065.181.0079	Junta da Flange BBA de Óleo	1
48.772-NA	071.151.102.6001	Junta da BBA de Óleo	2
48.900-KB		Kit de Borrachas	1
48.909-KA		Kit de Arruelas	1
48.921-CH	345.142.7060	Junta do Coletor de Escape.	6
48.922-BBS	346.141.0180	Junta do Coletor de Admissão	2
48.926-BBS	346.016.0221	Junta da Tampa de Válvulas	6
48.927-NA	355.015.0022	Junta da Tampa Lateral das Válvulas	2
48.928-NA	356.015.0121	Junta da Tampa Lateral do Motor	1
48.931-CHA	344.492.0080	Junta da Saída do Escape.	1
48.937-NA	355.188.0080	Jogo de Juntas da BBA de Óleo	1
48.938-NA	355.184.0480	Junta do Filtro do Óleo ao Bloco	1
48.939-NA	326.997.0149	Junta do Cavalete da BBA D'Água	6
48.940-NA	355.201.0080	Junta do Arrefecimento do Motor	2
48.941-NA	355.203.0080	Junta da Válvula Termostática ao Bloco	1
48.942-NA	346.077.0380	Junta do Regulador da BBA Injetora	2
48.943-NA	356.201.0180	Junta da BBA D'Água	1
48.945-NA	327.075.0180	Junta da Vedação Corpo do Mancal	1
48.946-NA	346.018.0080	Junta do Bocal do Enchimento de Óleo	1
48.948-NA	000.131.1479	Junta do Compressor	1
48.949-NA	000.131.1679	Jogo de Juntas do Compressor de Ar	1
48.958-NA	303.018.0079	Junta da Vareta do Óleo	1
48.959-NA	07.151.104.0017	Junta do Tubo de Ventilação	1
48.966-NA		Junta do Refrigerador de Óleo	2
48.976-BO	355.201.0178	Anel de Borracha	1
48.987-BO		Borracha da Admissão	5
59.260-DVM		Jogo de Juntas da Turbina (Somente para Jogo Turbinado)	1
9.0269-S	004.997.3947	Retentor Virabrequim Dianteiro	1
9.1815-S	352.053.0269	Retentor Haste de Válvulas	1
9.7013-S	315.030.0080	Retentor do Volante	1

TODAS AS PEÇAS SÃO FORNECIDAS INDIVIDUALMENTE

OM 366 Aspirado (871...) - 6 Cilindros

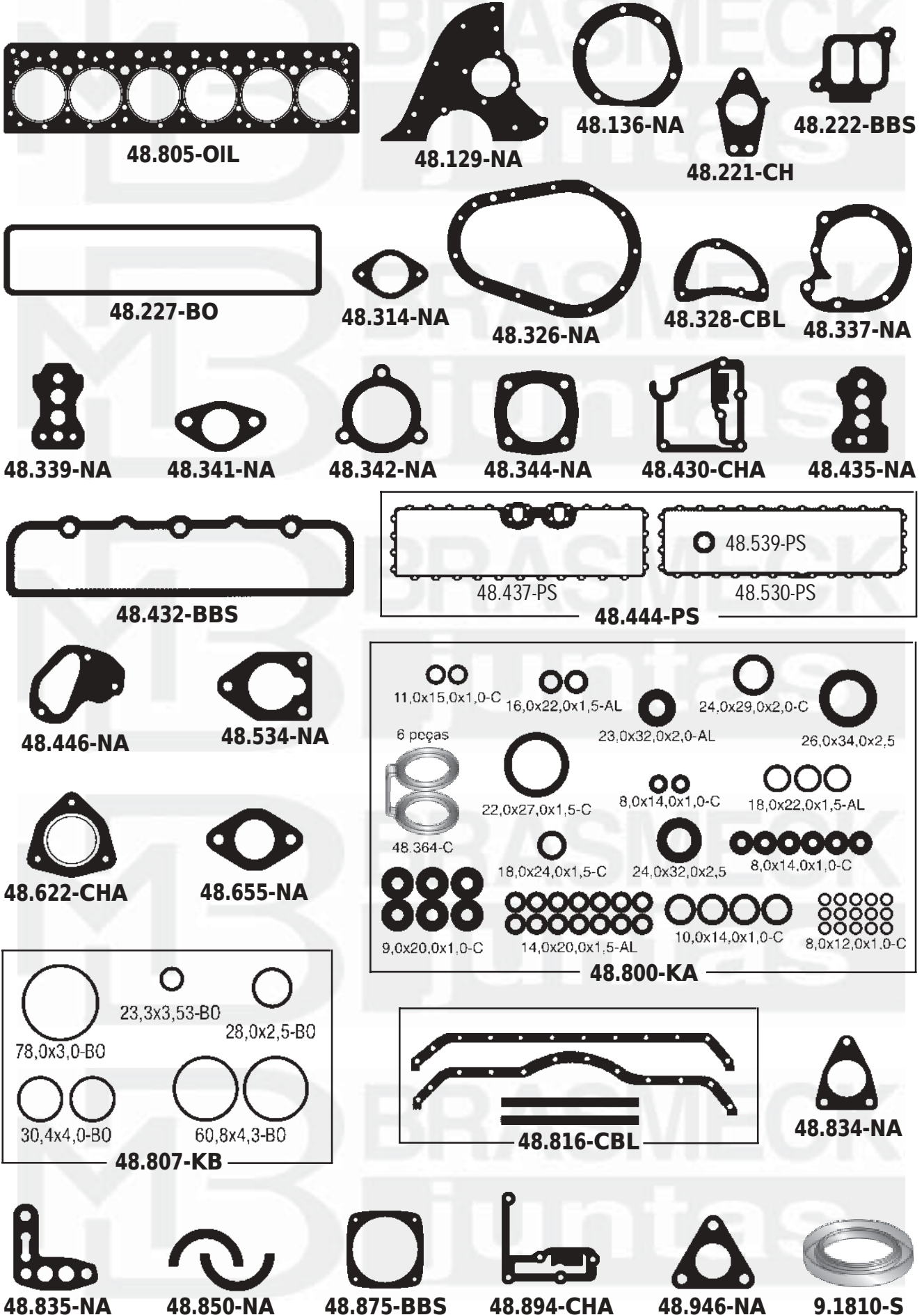

DESENHOS FORA DE ESCALA

OM 366A Turbinado (87/...) - 6 Cilindros

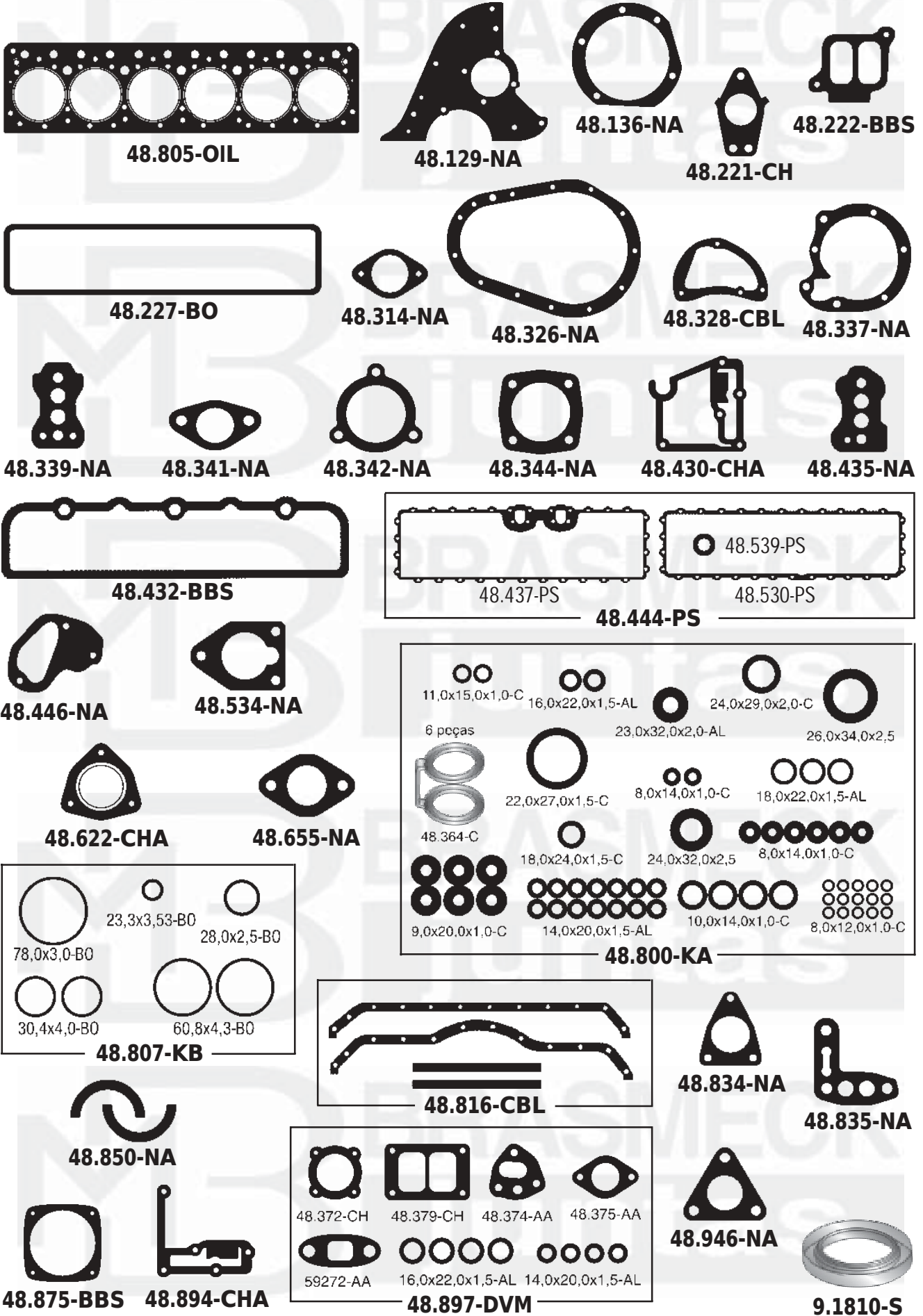

DESENHOS FORA DE ESCALA

BR 400 - 5 Cilindros - Motor 449



48.401-OIL



48.404-BO

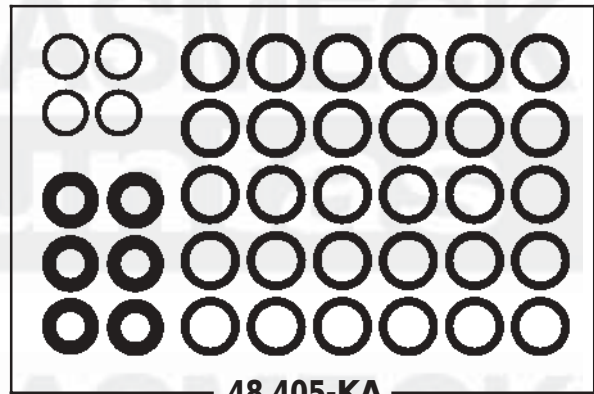

48.405-KA

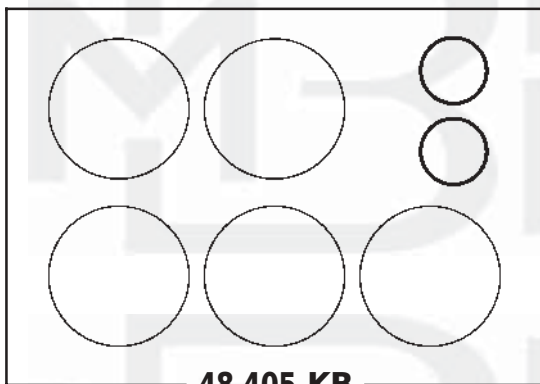

48.405-KB



48.416-NA



48.420-CH



48.423-BBS



48.425-NA



48.428-NA

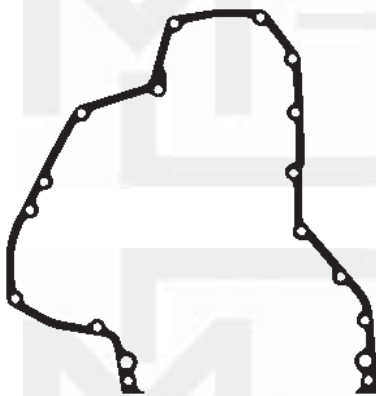

48.429-NA



48.431-NA



48.433-NA



48.438-NA



48.439-NA



48.440-NA



48.441-NA



48.445-CB



48.457-NA



48.458-NA



48.459-NA



48.460-CHA



48.465-NA



48.466-NA



48.471-NA



48.472-NA



48.473-BO



48.775-NA



9.2786-S



9.2696-S



9.2697-S

DESENHOS FORA DE ESCALA

BR 400 - 6 Cilindros - Motor 447



48.401-OIL



48.404-BO

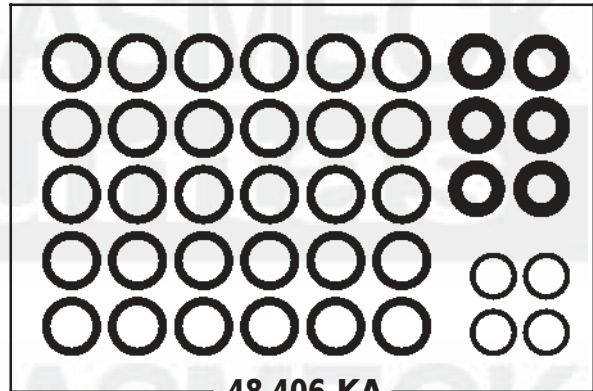

48.406-KA

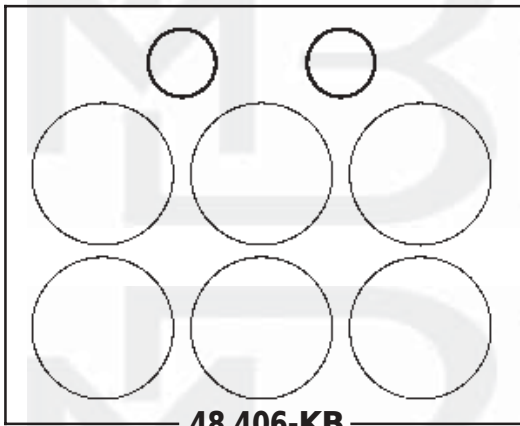

48.406-KB



48.417-NA



48.420-CH



48.423-BBS



48.425-NA



48.428-NA



48.429-NA



48.431-NA



48.433-NA



48.438-NA



48.439-NA



48.440-NA



48.441-NA



48.445-CB



48.457-NA



48.458-NA



48.459-NA



48.460-CHA



48.465-NA



48.466-NA



48.471-NA



48.472-NA



48.473-BO



48.775-NA



9.2786-S



9.2696-S

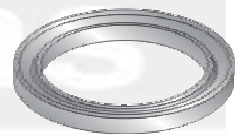

9.2697-S

DESENHOS FORA DE ESCALA

OM 457 Eletrônico - 6 Cilindros

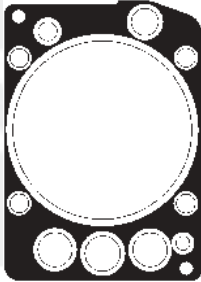

48.501-OIL



48.417-NA



48.420-CH



48.428-NA

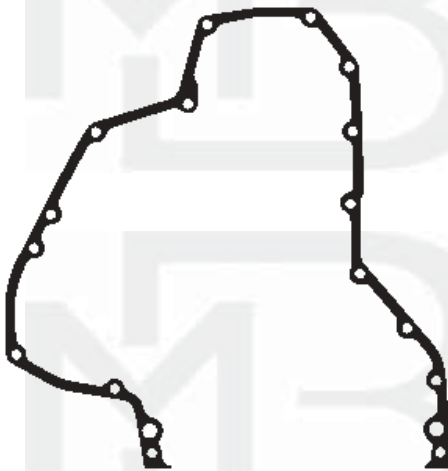

48.429-NA



48.431-NA



48.433-NA



48.440-NA



48.441-NA



48.445-CB



48.466-NA



48.502-CH



48.503-BO

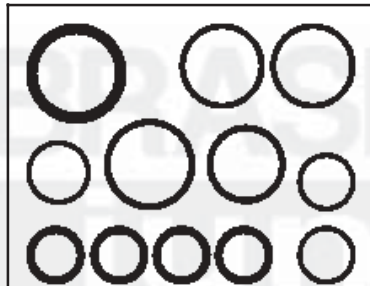

48.506-KA

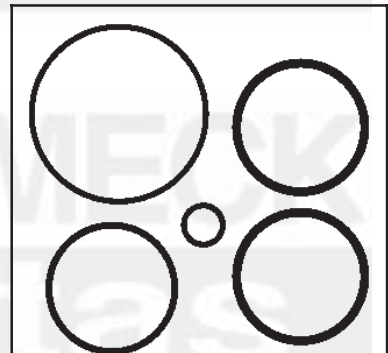

48.506-KB



48.513-NA



48.514-NA



48.520-NA



48.523-CHA



48.525-NA



48.775-NA



48.925-NA

DESENHOS FORA DE ESCALA

OM-314 (72/...) 4 CILINDROS

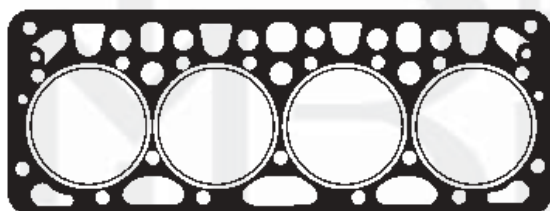
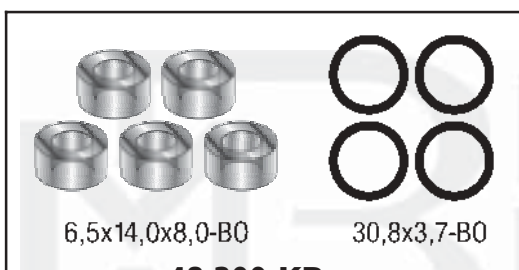
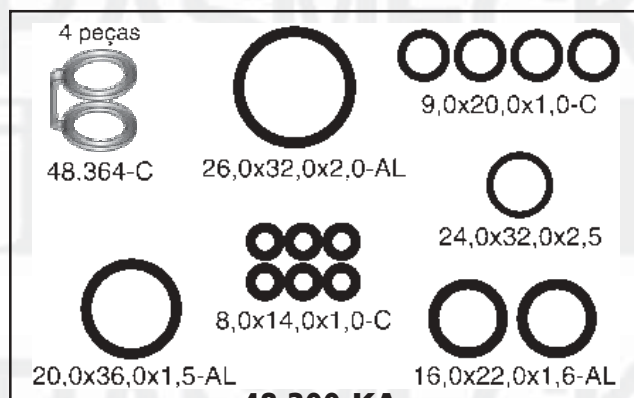
48.301-OIL

48.300-KB

48.300-KA

48.321-BBS

48.332-BBS

48.338-NA

48.341-NA

48.347-NA

48.346-NA

48.448-NA

DESENHOS FORA DE ESCALA

CÓDIGO BRASMECK	CÓDIGO ORIGINAL	DESCRIÇÃO	QTDE.
48.311-C		Jogo de Juntas para Retificação de Válvulas c/ Cabeçote Modelos 324 / L608 / 609-D / FAM	
48.311-S		Jogo de Juntas para Retificação de Válvulas s/ Cabeçote Modelos 324 / L608 / 609-D / FAM	
48.301-OIL	314.016.0220	Junta do Cabeçote Ø 100mm	1
48.300-KA		Kit de Arruelas	1
48.300-KB		Kit Anéis de Borrachas	1
48.321-BBS	314.142.0180	Junta do Escape.	1
48.332-BBS	314.016.0121	Junta da Tampa de Válvulas	1
48.338-NA	314.016.0280	Junta do Tubo de Sucção do Óleo	1
48.341-NA	352.203.0680	Junta do Cavalete D'Água	2
48.346-NA	352.203.0480	Junta do Termostato	1
48.347-NA	352.203.0080	Junta do Alojamento da Válvula Termostática	2
48.448-NA	352.203.0780	Junta do Termostato	1

TODAS AS PEÇAS SÃO FORNECIDAS INDIVIDUALMENTE

OM-364 (87/...) Aspirado / Turbinado 4 Cilindros

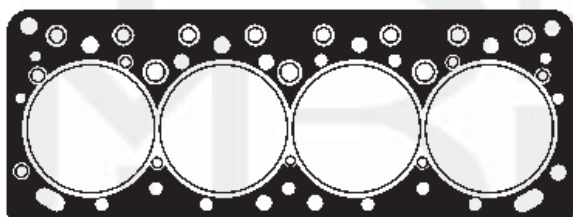
48.305-OIL

48.221-CH

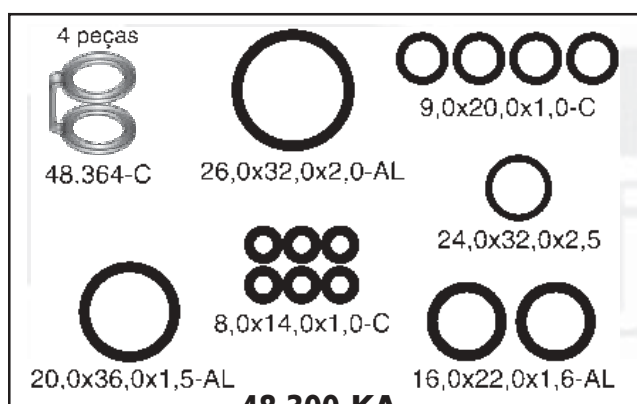
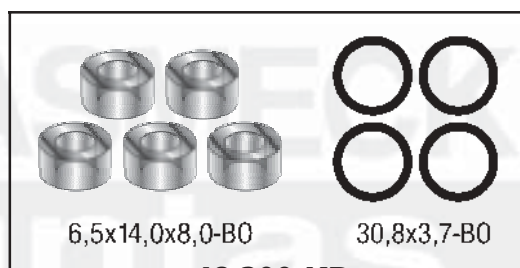
48.222-BBS

48.300-KA

48.300-KB

48.341-NA

48.426-BBS

48.446-NA

48.834-NA

48.448-NA

DESENHOS FORA DE ESCALA

CÓDIGO BRASMECK	CÓDIGO ORIGINAL	DESCRIÇÃO	QTDE.
48.312-C		Jogo de Juntas para Retificação de Válvulas c/ Cabeçote Modelos 709 / 710 / 912 / 1114 /Toyota	
48.312-S		Jogo de Juntas para Retificação de Válvulas s/ Cabeçote Modelos 709 / 710 / 912 / 1114 /Toyota	
48.305-OIL	364.016.0320	Junta do Cabeçote Ø 100mm	1
48.221-CH	366.142.0180	Junta do Coletor do Escape.	3
48.222-BBS	366.141.0280	Junta do Coletor de Admissão	2
48.300-KA		Kit de Arruelas	1
48.300-KB		Kit Anéis de Borrachas	1
48.341-NA	352.203.0680	Junta do Cavalete D'Água	2
48.426-BBS	364.016.0021	Junta da Tampa de Válvulas	1
48.446-NA	366.203.0080	Junta do Termostato	1
48.448-NA	352.203.0780	Junta do Termostato	1
48.834-NA	000.091.1280	Junta da BBA Alimentadora	1

TODAS AS PEÇAS SÃO FORNECIDAS INDIVIDUALMENTE

OM-352 (70/...) Aspirado / Turbinado 6 Cilindros

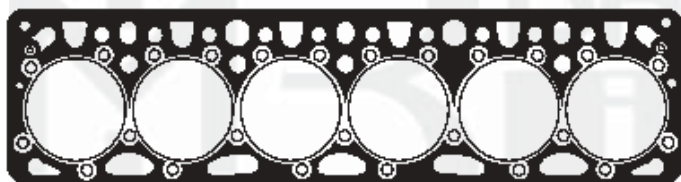

48.802-OIL



48.341-NA



48.346-NA



48.347-NA



48.448-NA



48.822-NA

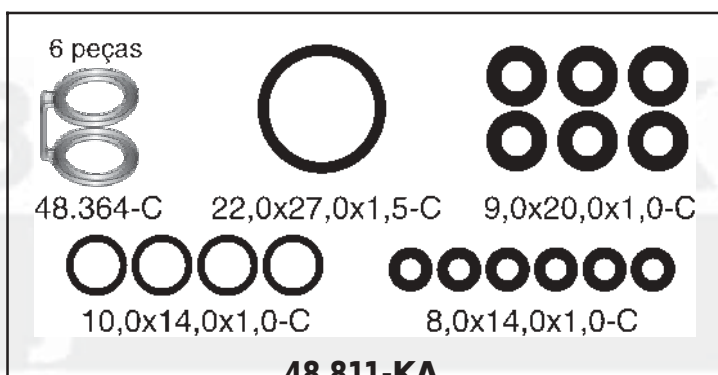

48.811-KA



48.832-BBS



48.849-NA



30,8x3,7-BO



6,5x14,0x8,0-BO



28,0x2,5-BO

CÓDIGO BRASMECK	CÓDIGO ORIGINAL	DESCRIÇÃO	QTDE.
48.811-C		Jogo de Juntas para Retificação de Válvulas c/ Cabeçote - Modelos 1111L / 1113L-LK / 1114L-LK / 1116L-LK / 1313L-LK 1314L-LK / 1316L-LK / 1513L-LK	
48.811-S		Jogo de Juntas para Retificação de Válvulas s/ Cabeçote - Modelos 1111L / 1113L-LK / 1114L-LK / 1116L-LK / 1313L-LK 1314L-LK / 1316L-LK / 1513L-LK	
48.802-OIL	352.016.0120	Junta do Cabeçote Ø 100mm	1
48.341-NA	352.203.0680	Junta do Cavalete D'Água	2
48.346-NA	352.203.0480	Junta do Termostato	1
48.347-NA	352.203.0080	Junta do Alojamento da Válvula Termostática	2
48.448-NA	352.203.0780	Junta do Termostato	1
48.811-KA		Kit Arruelas para Retificação	1
48.822-CH	352.142.0280	Jogo de Juntas do Escape.	2
48.832-BBS	352.016.0421	Junta da Tampa de Válvulas	1
48.849-NA	715.110.2206	Junta da Flange do Cano D'Água	1
		Borracha do Cano Injetor (6,5 x 14,0 x 8,0)	7
		Borracha Antecâmara (30,8 x 3,7)	6
		Borracha (28,0 x 2,5)	1

TODAS AS PEÇAS SÃO FORNECIDAS INDIVIDUALMENTE

OM 355 (85/...) 5 Cilindros

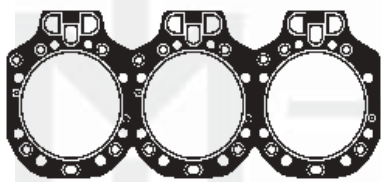
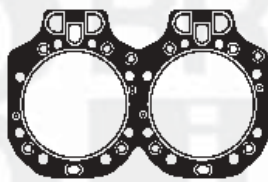
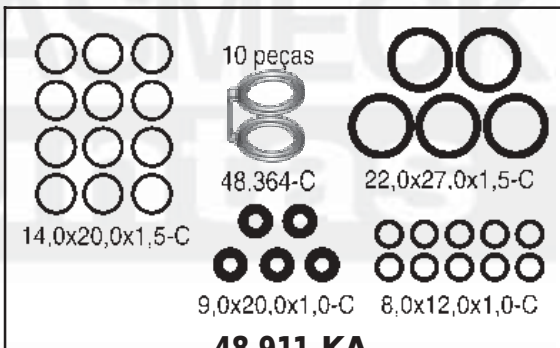
48.901-OIL

48.902-OIL

10 peças

48.364-C

22,0x27,0x1,5-C

14,0x20,0x1,5-C



9,0x20,0x1,0-C

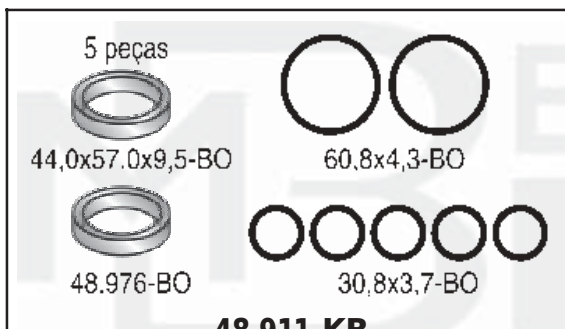

8,0x12,0x1,0-C

48.911-KA

5 peças

44,0x57,0x9,5-BO



60,8x4,3-BO



48.976-BO



30,8x3,7-BO

48.911-KB

48.921-CH

48.922-BBS

48.920-BBS
48.923-BBS

48.926-BBS

48.940-NA

48.941-NA

48.939-NA

9.1815-S

DESENHOS FORA DE ESCALA

CÓDIGO BRASMECK	CÓDIGO ORIGINAL	DESCRIÇÃO	QTDE.
48.911-C		Jogo de Juntas para Retificação de Válvulas c/ Cabeçote - Modelos OF 0370 / 371 / 1524L / 1525LK / 1924L / 1925LK 1932L / 1933LK / FAM	
48.911-S		Jogo de Juntas para Retificação de Válvulas s/ Cabeçote - Modelos OF 0370 / 371 / 1524L / 1525LK / 1924L / 1925LK 1932L / 1933LK / FAM	
48.901-OIL	355.016.0220	Junta do Cabeçote – 3 cilindros	1
48.902-OIL	345.016.0020	Junta do Cabeçote – 2 cilindros	1
48.911-KA		Kit Arruelas para Retificação	1
48.911-KB		Kit Borrachas para Retificação	1
48.921-CH	345.142.7060	Junta do Coletor de Escape.	5
48.923-BBS		Jogo de Juntas do Coletor de Admissão	1
48.926-BBS	346.016.0221	Junta da Tampa de Válvulas	5
48.939-NA	326.997.0149	Junta do Cavalete da BBA D'Água	5
48.940-NA	355.201.0080	Junta do Arrefecimento do Motor	2
48.941-NA	355.203.0080	Junta da Válvula Termostática ao Bloco	1
9.1815-S	352.053.0269	Retentor Haste de Válvulas	20

TODAS AS PEÇAS SÃO FORNECIDAS INDIVIDUALMENTE

OM 355 (85/...) 6 Cilindros



48.901-OIL

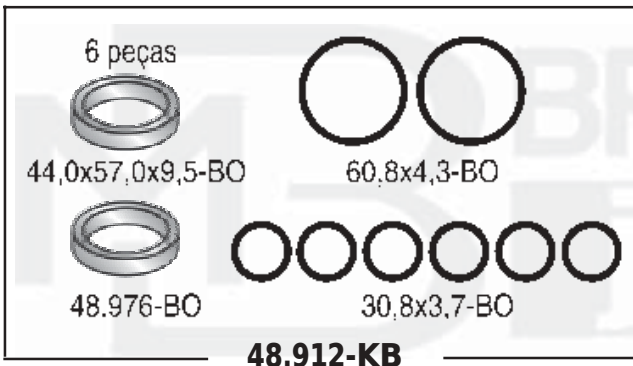
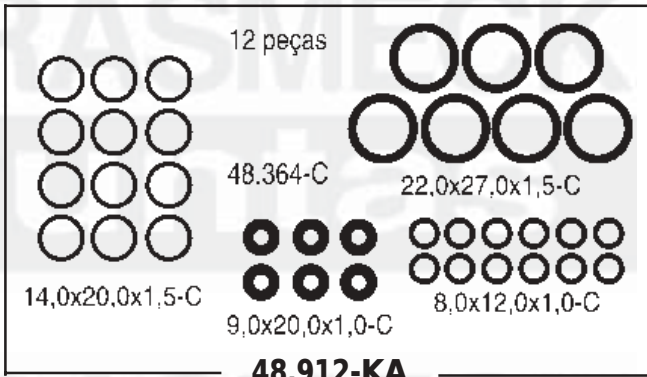

48.921-CH



48.922-BBS



48.926-BBS



48.939-NA



48.940-NA



48.941-NA



9.1815-S

CÓDIGO BRASMECK	CÓDIGO ORIGINAL	DESCRIÇÃO	QTDE.
48.912-C		Jogo de Juntas para Retificação de Válvulas c/ Cabeçote - Modelos OF 0370 / 371 / 1524L / 1525LK / 1525LK / 1924L 1925LK / 1932L / 1933LK / FAM	
48.912-S		Jogo de Juntas para Retificação de Válvulas s/ Cabeçote - Modelos OF 0370/ 371 / 1524L / 1525LK / 1525LK / 1924L 1925LK / 1932L / 1933LK / FAM	
48.901-OIL	355.016.0220	Junta do Cabeçote – 3 cilindros	2
48.912-KA		Kit Arruelas para Retificação	1
48.912-KB		Kit Borracha para Retificação	1
48.921-CH	345.142.7060	Junta do Coletor de Escape.	6
48.922-BBS	346.141.0180	Junta do Coletor de Admissão	2
48.926-BBS	346.016.0221	Junta da Tampa de Válvulas	6
48.939-NA	326.997.0149	Junta do Cavalete da BBA D'Água	6
48.940-NA	355.201.0080	Junta do Arrefecimento do Motor	2
48.941-NA	355.203.0080	Junta da Válvula Termostática ao Bloco	1
9.1815-S	352.053.0269	Retentor Haste de Válvulas	24

TODAS AS PEÇAS SÃO FORNECIDAS INDIVIDUALMENTE

OM-366 (87/...) Aspirado / Turbinado 6 Cilindros



48.805-OIL



48.221-CH



48.222-BBS



48.341-NA



48.432-BBS



48.446-NA

6 peças



48.364-C



22,0x27,0x1,5-C



9,0x20,0x1,0-C



10,0x14,0x1,0-C



8,0x14,0x1,0-C

48.811-KA

30,8x3,7-BO

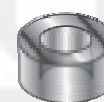

6,5x14,0x8,0-BO

DESENHOS FORA DE ESCALA

CÓDIGO BRASMECK	CÓDIGO ORIGINAL	DESCRIÇÃO	QTDE.
48.812-C		Jg. de Jtas. p/ Retificação das Válvulas c/ Cab. - Modelos 1214LK / 1414LK / 1218L / 1418K / 1618LK / 1718K / 2318LK / 2418 / 1621LK / 1721S / 1620 / 1720	
48.812-S		Jg. de Jtas. p. Retificação das Válvulas s/ Cab. - Modelos 1214LK / 1414LK / 1218L / 1418K / 1618LK / 1718K / 2318LK / 2418 / 1621LK / 1721S / 1620 / 1720	
48.805-OIL	366.016.0020	Junta do Cabeçote Ø 100mm	1
48.221-CH	366.142.0180	Junta do Coletor de Escape.	4
48.222-BBS	366.141.0280	Junta do Coletor de Admissão	3
48.341-NA	352.203.0680	Junta do Cavalete D'Água	2
48.432-BBS	366.016.0021	Junta da Tampa de Válvulas	1
48.446-NA	366.203.0080	Junta do Termostato	1
48.811-KA		Kit Arruelas para Retificação	1
		Borracha Antecâmara (30,8 x 3,7)	6
		Borracha Cano Injetor (6,5 x 14,0 x 8,0)	7

TODAS AS PEÇAS SÃO FORNECIDAS INDIVIDUALMENTE

BR 400 – Motor 449 / 447



48.401-OIL



48.420-CH



48.423-BBS



48.425-NA



9.2786-S



20,0x9,0x1,0

DESENHOS FORA DE ESCALA

CÓDIGO BRASMECK	CÓDIGO ORIGINAL	DESCRIÇÃO	QTDE.
48.411-C		Jogo de Juntas para Retificação de Válvulas c/ Cabeçote Modelos 1625LS / 2325L-LK-LB / 1630 LS (p/ 1 cil)	
48.411-S		Jogo de Juntas para Retificação de Válvulas s/ Cabeçote Modelos 1625LS / 2325L-LK-LB / 1630 LS (p/ 1 cil)	
48.401-OIL	422.016.0420	Junta do Cabeçote	1
48.404-BO		Junta Tampão do Bico Injetor	1
48.420-CH	403.142.0380	Junta do Escape.	1
48.423-BBS	442.141.0480	Junta de Admissão	1
48.425-NA	403.016.0321	Junta da Tampa de Válvulas	1
9.2786-S		Retentor de Haste de Válvulas	2
		Arruela 20 x 9,0 x 1,0	1

TODAS AS PEÇAS SÃO FORNECIDAS INDIVIDUALMENTE

OM-457 Eletrônico

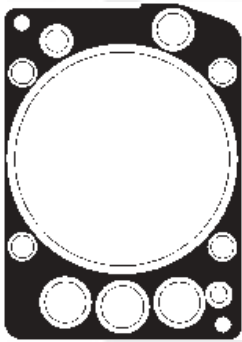

48.501-OIL



48.420-CH



48.503-CH

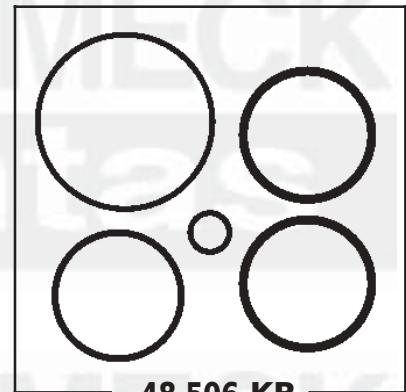

48.506-KB

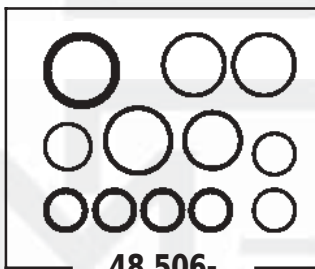

48.506-KA



48.523-CHA



48.925-NA

DESENHOS FORA DE ESCALA

CÓDIGO BRASMECK	CÓDIGO ORIGINAL	DESCRIÇÃO	QTDE.
48.511-CS	457.010.0005	Jogo de Juntas para Retificação de Válvula c/ Cabeçote Motores 1938 Eletrônico (p/ 1 cil)	
48.511-SS		Jogo de Juntas para Retificação de Válvula s/ Cabeçote Motores 1938 Eletrônico (p/ 1 cil)	
48.501-OIL	A-460.016.0320	Junta do Cabeçote	1
48.420-CH	403.142.0380	Junta do Escapamento	1
48.503-BO		Anéis da Camisa	2
48.506-KA		Kit de Arruelas	1
48.506-KB		Kit de Anéis de Borracha	1
48.523-CHA	A-457.141.0080	Junta do Coletor de Admissão	1
48.925-NA	A-457.016.0021	Junta da Tampa das Válvulas	1

TODAS AS PEÇAS SÃO FORNECIDAS INDIVIDUALMENTE

ZF 16S 130/160/190 – MBB 1929/1932/1933/1934/1938/1941/LS 1632/LS 1938



48.090-NA



48.092-NA

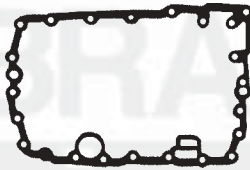

48.093-NA



48.094-NA



48.095-NA



48.096-NA



48.097-NA



48.098-NA



48.099-NA



48.994-NA

DESENHOS FORA DE ESCALA

CÓDIGO BRASMECK	CÓDIGO ORIGINAL	DESCRIÇÃO	QTDE.
48.091-NA	129.529.8891	Jogo de Juntas do Cambio	
48.090-NA		Junta do Câmbio	1
48.092-NA	129.630.1005	Junta do Câmbio	1
48.093-NA	129.630.1189	Junta do Câmbio	1
48.094-NA	129.730.2022	Junta do Câmbio	1
48.095-NA	129.630.1007	Junta do Câmbio	1
48.096-NA	129.530.7076	Junta do Câmbio	2
48.097-NA	129.530.7053	Junta do Câmbio	2
48.098-NA	129.730.7053	Junta do Câmbio	1
48.099-NA	129.530.6041	Junta do Câmbio	1
48.994-NA	000.264.2980	Junta da Tampa da Carcaça	1

OM-364 / OM-314 / 608-D 72 ED – CX. G-20 / 24



48.181-PS



48.182-PS



48.183-PS



48.185-NA



48.294-PS

DESENHOS FORA DE ESCALA

CÓDIGO BRASMECK	CÓDIGO ORIGINAL	DESCRIÇÃO	QTDE.
48.180-PS	98.308.586.0026	Jogo de Juntas do Cambio	
48.181-PS	314.261.0280	Junta da Tampa Superior	1
48.182-PS	314.261.0480	Junta da Tampa Traseira Interna	1
48.183-PS	312.261.1079	Junta da Tampa Dianteira	1
48.185-NA	312.261.1080	Junta Lateral da Tampa Superior	1
48.294-PS	312.261.2179	Junta da Tampa Engrenagem Principal	1

TODAS AS PEÇAS SÃO FORNECIDAS INDIVIDUALMENTE

M.B.B 709 / 710 – CX. G-20 / 24



48.181-PS



48.182-PS



48.183-PS



48.185-NA



48.294-PS



48.695-NA

DESENHOS FORA DE ESCALA

CÓDIGO BRASMECK	CÓDIGO ORIGINAL	DESCRIÇÃO	QTDE.
48.190-PS		Jogo de Juntas do Cambio	
48.181-PS	314.261.0280	Junta da Tampa Superior	1
48.182-PS	314.261.0480	Junta da Tampa Traseira Interna	1
48.183-PS	312.261.1079	Junta da Tampa Dianteira	1
48.185-NA	312.261.1080	Junta Lateral da Tampa Superior	1
48.294-PS	312.261.2179	Junta da Tampa Engrenagem Principal	1
48.695-PS		Junta da Caixa de Câmbio	1

ZF-OH 1620 (Ônibus) OF 1620 (Caminhão)



48.394-NA



48.396-NA



48.490-NA



48.491-NA



48.492-NA



48.493-NA

DESENHOS FORA DE ESCALA

CÓDIGO BRASMECK	CÓDIGO ORIGINAL	DESCRIÇÃO	QTDE.
48.299-NA		Jogo de Juntas do Cambio	
48.394-NA		Junta do Câmbio	1
48.396-NA		Junta do Câmbio	1
48.490-NA		Junta do Câmbio	1
48.491-NA		Junta do Câmbio	1
48.492-NA		Junta do Câmbio	1
48.493-NA		Junta do Câmbio	1

TODAS AS PEÇAS SÃO FORNECIDAS INDIVIDUALMENTE

OM-321 / 352 / 352 A – Cx. – G3/36 – G40/60



48.184-PS



48.386-PS



48.387-PS



48.388-PS



48.389-PS



48.391-PS



48.392-PS



48.393-PS



48.395-PS

DESENHOS FORA DE ESCALA

CÓDIGO BRASMECK	CÓDIGO ORIGINAL	DESCRIÇÃO	QTDE.
48.380-PS	345.586.7026	Jogo de Juntas do Câmbio	
48.184-PS	312.261.2179	Junta da Engrenagem Principal	1
48.386-PS	312.261.1379	Junta da Tampa Traseira Intermediária	1
48.387-PS	321.261.0779	Junta da Tampa Dianteira	1
48.388-PS	321.261.1279	Junta da Tampa Superior	1
48.389-PS	321.261.1479	Junta da Tampa Traseira	1
48.391-PS	321.261.0979	Junta Lateral da Tampa Superior	1
48.392-PS	321.261.2079	Junta Lateral da Tampa Superior	1
48.393-PS	321.261.1979	Junta do Suporte da Alavanca	1
48.395-PS	321.261.2179	Junta Lateral da Tampa Superior	1

OM-352 / 352 A / 2013 / 2213 / 2218 (Antiga)



48.582-NA



48.583-NA



48.584-NA

DESENHOS FORA DE ESCALA

CÓDIGO BRASMECK	CÓDIGO ORIGINAL	DESCRIÇÃO	QTDE.
48.581-NA	352.281.0097	Jogo de Juntas do Câmbio	
48.582-NA	352.281.0179	Junta do Câmbio	1
48.583-NA	352.281.0580	Junta do Câmbio	1
48.584-NA	352.281.0280	Junta do Câmbio	1

TODAS AS PEÇAS SÃO FORNECIDAS INDIVIDUALMENTE

LP 321 / OM-352 / 352 A / OM-326 / OM-355/6 CILS / OM-366/366 A Caminhões e Ônibus



48.184-PS



48.294-PS



48.386-PS



48.387-PS



48.388-PS



48.389-PS



48.390-PS



48.391-PS



48.392-PS



48.393-PS



48.395-PS



48.489-PS



48.989-PS

DESENHOS FORA DE ESCALA

CÓDIGO BRASMECK	CÓDIGO ORIGINAL	DESCRIÇÃO	QTDE.
48.480-PS	345.586.7026	Jogo de Juntas do Câmbio	
48.184-PS	312.261.2179	Junta da Engrenagem Principal	1
48.294-PS	317.261.1479	Junta da Tampa Engrenagem Principal	1
48.386-PS	312.261.1379	Junta da Tampa Traseira Intermediária	1
48.387-PS	321.261.0779	Junta da Tampa Dianteira	1
48.388-PS	321.261.1279	Junta da Tampa Superior	1
48.389-PS	321.261.1479	Junta da Tampa Traseira	1
48.390-PS	321.261.0280	Junta Lateral da Tampa Superior	1
48.391-PS	321.261.0979	Junta Lateral da Tampa Superior	1
48.392-PS	321.261.2079	Junta Lateral da Tampa Superior	1
48.393-PS	321.261.1979	Junta da Tampa Superior da Alavanca	1
48.395-PS	321.261.2179	Junta Lateral da Tampa Superior	1
48.489-PS	381.261.0180	Junta da Tampa Retentora	1
48.989-PS	337.261.0079	Junta da Engrenagem da Redução	1

TODAS AS PEÇAS SÃO FORNECIDAS INDIVIDUALMENTE

ZF S-5 6.80 M.B.B. OF-1620 / 1318 / L-1620 / OH-1421 / OH-1318 / 1418



48.490-NA



48.652-NA



48.654-NA



48.656-NA



48.657-NA



48.658-NA



48.659-NA

DESENHOS FORA DE ESCALA

CÓDIGO BRASMECK	CÓDIGO ORIGINAL	DESCRIÇÃO	QTDE.
48.650-NA	002.608.100	Jogo de Juntas do Câmbio	
48.490-NA		Junta da Tampa do Câmbio	1
48.652-NA		Junta da Moringa	1
48.654-NA		Junta do Câmbio	1
48.656-NA		Junta da Tomada de Força	1
48.657-NA		Junta do Câmbio	1
48.658-NA		Junta da Tampa Lateral	1
48.659-NA		Junta do Câmbio	1

OM-366 / VG-500 (moderna)

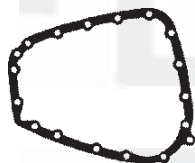

48.682-NA



48.683-NA



48.684-NA



48.685-NA



48.686-GV



48.687-GV

DESENHOS FORA DE ESCALA

CÓDIGO BRASMECK	CÓDIGO ORIGINAL	DESCRIÇÃO	QTDE.
48.681-NA		Jogo de Juntas do Câmbio	
48.682-NA		Junta do Câmbio	1
48.683-NA		Junta do Câmbio	1
48.684-NA	746143	Junta do Câmbio	1
48.685-NA		Junta do Câmbio	1
48.686-GV		Junta do Câmbio	1
48.687-GV		Junta do Câmbio	1

TODAS AS PEÇAS SÃO FORNECIDAS INDIVIDUALMENTE

G3-55 (Veicular) M.B.B 1214/1218/1414/1614/1618/1714/1718 / LK-1620/1718K/1218



48.389-NA



48.689-NA



48.691-NA



48.692-CB



48.693-CB



48.694-NA



48.695-NA



48.696-NA



48.697-NA

CÓDIGO BRASMECK	CÓDIGO ORIGINAL	DESCRIÇÃO	QTDE.
48.690-NA	384.260.4400	Jogo de Juntas do Câmbio	
48.389-NA	321.261.1479	Junta da Tampa Traseira	1
48.689-NA		Junta Redução Câmbio	1
48.691-NA		Junta da Tampa da Caixa	1
48.692-CB		Junta da Caixa de Câmbio	1
48.693-CB		Junta da Caixa de Câmbio	1
48.694-NA		Junta da Moringa	1
48.695-NA		Junta da Caixa de Câmbio	1
48.696-NA		Junta da Tampa Traseira	1
48.697-NA		Junta da Caixa de Câmbio	1

ZF S6-820 M.B.B LK 1123 / 1723 / Volvo Ônibus B-7



48.657-NA



48.658-NA

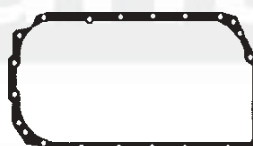

48.971-NA



48.972-NA



48.973-NA



48.974-NA



48.994-NA

CÓDIGO BRASMECK	CÓDIGO ORIGINAL	DESCRIÇÃO	QTDE.
48.970-NA	1.311.298.800	Jogo de Juntas do Câmbio	
48.657-NA		Junta do Câmbio	1
48.658-NA		Junta da Tampa Lateral	1
48.971-NA		Junta da Tampa do Câmbio	1
48.972-NA		Junta do Câmbio	1
48.973-NA		Junta do Câmbio	1
48.974-NA		Junta do Câmbio	1
48.994-NA	000.264.2980	Junta da Tampa da Carcaça	1

TODAS AS PEÇAS SÃO FORNECIDAS INDIVIDUALMENTE

ZF-S 6-90 / OM-370 / Volvo B-58



48.085-GV

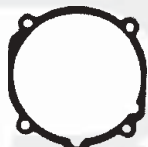

48.086-GV



48.087-GV



48.088-GV



48.089-GV



48.484-GV



48.488-GV



48.991-GV



48.994-GV



48.996-GV

DESENHOS FORA DE ESCALA

CÓDIGO BRASMECK	CÓDIGO ORIGINAL	DESCRIÇÃO	QTDE.
48.981-GV	009.029.8189	Jogo de Juntas do Câmbio	
48.085-GV		Junta do Câmbio	1
48.086-GV		Junta do Câmbio	1
48.087-GV		Junta do Câmbio	1
48.088-GV		Junta Traseira do Câmbio	1
48.089-GV		Junta do Câmbio	1
48.484-GV	000.268.2180	Junta do Tubo da Flange	1
48.488-GV	000.268.0980	Junta Válv. Distribuição	1
48.991-GV	125.030.6182	Junta da Tampa Lateral	1
48.994-GV	000.264.2980	Junta da Tampa da Carcaça	1
48.996-GV	336.268.0179	Junta da Tampa Trambulador	2

OM-326 / 352 / 321 Ônibus



48.294-PS



48.386-PS

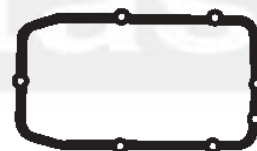

48.388-PS



48.389-PS



48.391-PS



48.988-PS



48.989-PS

DESENHOS FORA DE ESCALA

CÓDIGO BRASMECK	CÓDIGO ORIGINAL	DESCRIÇÃO	QTDE.
48.980-PS	983.455.860.326	Jogo de Juntas do Câmbio	
48.294-PS	317.261.1479	Junta da Tampa Engrenagem Principal	1
48.386-PS	321.261.1379	Junta da Tampa Traseira Intermediária	1
48.388-PS	321.261.1279	Junta da Tampa Superior	1
48.389-PS	321.261.1479	Junta da Tampa Traseira	1
48.391-PS	321.261.0979	Junta Lateral da Tampa Superior	1
48.988-PS	322.261.0280	Junta da Tampa da Caixa	1
48.989-PS	337.261.0079	Junta da Engrenagem da Redução	1

TODAS AS PEÇAS SÃO FORNECIDAS INDIVIDUALMENTE

ZF-S 6-80 / M.B.B 1519 / 2219 / 1520 / 2220 (Caminhões)



48.085-GV



48.086-GV



48.089-GV



48.484-GV



48.488-GV



48.991-GV



48.992-GV

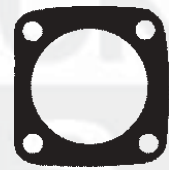

48.994-GV



48.995-GV



48.996-GV



50.486-GV

DESENHOS FORA DE ESCALA

CÓDIGO BRASMECK	CÓDIGO ORIGINAL	DESCRIÇÃO	QTDE.
48.982-GV	125.029.800.002	Jogo de Juntas do Câmbio	
48.085-GV		Junta do Câmbio	1
48.086-GV		Junta do Câmbio	1
48.089-GV		Junta do Câmbio	1
48.484-GV	000.268.2180	Junta do Tubo da Flange	1
48.488-GV	000.268.0980	Junta da Válvula de Distribuição	1
48.991-GV	125.033.06182	Junta da Tampa Superior	1
48.992-GV		Junta da Tampa Traseira	1
48.994-GV	000.264.2980	Junta da Tampa da Carcaça	1
48.995-GV		Junta do Câmbio	1
48.996-GV	336.268.0179	Junta da Tampa do Trambulador	2
50.486-GV		Junta da Tampa Dianteira	1

TODAS AS PEÇAS SÃO FORNECIDAS INDIVIDUALMENTE

ZF 4K 120/121 – OM-355/6 – 1924 / 1924 A / 1524 / 1525

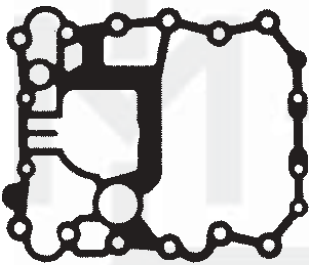

48.483-NA



48.484-NA

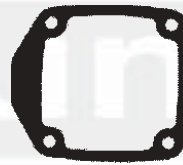

48.485-NA

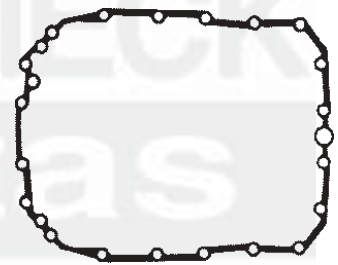

48.486-NA

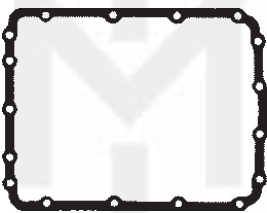

48.487-NA



48.488-NA



48.482-NA



48.494-NA



48.495-NA



48.994-NA



48.996-NA

DESENHOS FORA DE ESCALA

CÓDIGO BRASMECK	CÓDIGO ORIGINAL	DESCRIÇÃO	QTDE.
48.990-NA	125.829.8885	Jogo de Juntas do Câmbio	
48.483-NA	000.268.2280	Junta da Carcaça Planetária	1
48.484-NA	000.268.2180	Junta do Tubo da Flange	1
48.485-GV	000.267.0187	Junta da Tampa Superior do Trambulador	1
48.486-NA	000.268.1980	Junta entre Carcaça	1
48.487-GV	000.268.1780	Junta da Tampa Lateral	1
48.488-NA	000.268.0980	Junta Válvula Termostática	1
48.489-NA		Junta do Câmbio	1
48.494-NA	000.262.1180	Junta Lateral Piloto	1
48.495-NA	000.264.2580	Junta Flange Saída	1
48.994-NA	000.264.2980	Junta da Tampa da Carcaça	1
48.996-NA	336.268.0179	Junta Tampa Inferior Trambulador	1

TODAS AS PEÇAS SÃO FORNECIDAS INDIVIDUALMENTE

Compressor OM-355 – Warco



48.263-NA



48.264-NA



48.265-BBS

CÓDIGO BRASMECK	CÓDIGO ORIGINAL	DESCRIÇÃO	QTDE.
48.260-DVM	000.130.3920	Jogo de Juntas do Compressor OM-355 – Warco	
48.263-NA	000.131.2079	Junta do Cilindro Compressor	1
48.264-NA	000.131.2179	Junta da Válvula Compressor	1
48.265-BBS	000.131.7780	Junta do Cabeçote Compressor	1

TODAS AS PEÇAS SÃO FORNECIDAS INDIVIDUALMENTE

Compressor de Ar Wabco OM-355



48.264-NA



48.265-BBS

CÓDIGO BRASMECK	CÓDIGO ORIGINAL	DESCRIÇÃO	QTDE.
48.261-DVM		Jogo de juntas do Compressor de Ar Wabco OM-355	
48.264-NA	000.131.2179	Junta da Válvula Compressor	
48.265-BBS	000.131.7780	Junta do Cabeçote Compressor	

TODAS AS PEÇAS SÃO FORNECIDAS INDIVIDUALMENTE

Compressor de Ar Motor 1114



48.342-NA



48.875-BBS

CÓDIGO BRASMECK	CÓDIGO ORIGINAL	DESCRIÇÃO	QTDE.
48.320-DVM		Jogo de Juntas do Compressor de Ar Motor 1114	
48.342-NA		Junta do Compressor	1
48.875-BBS		Junta do Cabeçote Compressor	1

TODAS AS PEÇAS SÃO FORNECIDAS INDIVIDUALMENTE

Compressor de Ar M.B.B. 352 / 352 A



48.342-NA



48.344-NA



48.875-BBS

CÓDIGO BRASMECK	CÓDIGO ORIGINAL	DESCRIÇÃO	QTDE.
48.350-DVM		Jogo de Juntas do Compressor de Ar M.B.B. 352 / 352 A	
48.342-NA		Junta do Compressor	1
48.344-NA		Junta do Compressor	1
48.875-BBS		Junta do Compressor	1

TODAS AS PEÇAS SÃO FORNECIDAS INDIVIDUALMENTE

Compressor OM-447 / 449



48.457-NA



48.458-NA



48.459-NA

CÓDIGO BRASMECK	CÓDIGO ORIGINAL	DESCRIÇÃO	QTDE.
48.470-DVM		Jogo de Juntas do Compressor OM-447 / 449	
48.457-NA	403.131.0780	Junta da Tampa Inferior do Compressor de Ar	1
48.458-NA	407.131.0780	Junta da Tampa de Válv. Cabeçote Compressor	1
48.459-NA	407.131.0880	Junta do Cabeçote Compressor	1

TODAS AS PEÇAS SÃO FORNECIDAS INDIVIDUALMENTE



CÓDIGO BRASMECK	CÓDIGO ORIGINAL	DESCRIÇÃO	QTDE.

TODAS AS PEÇAS SÃO FORNECIDAS INDIVIDUALMENTE

DESENHOS FORA DE ESCALA

Compressor Wabco – M.B.B. OM-366



48.661-NA



48.662-NA



48.663-NA



CÓDIGO BRASMECK	CÓDIGO ORIGINAL	DESCRIÇÃO	QTDE.
48.660-NA		Jogo de Juntas do Compressor Wabco – M.B.B. OM-366	
48.661-NA	897.316.996.4	Junta do Cabeçote Compressor	1
48.662-NA	897.316.995.2	Junta do Cabeçote Compressor	1
48.663-NA	897.316.995.2	Junta do Cabeçote Compressor	1
		Anel de Borracha	1
		Arruela	1
		Arruela	1

DESENHOS FORA DE ESCALA

Compressor de Ar Knorr LK 15 M.B.B. OM-366 93/...



48.671-NA



48.672-NA



48.673-NA



48.948-NA



48.954-NA

CÓDIGO BRASMECK	CÓDIGO ORIGINAL	DESCRIÇÃO	QTDE.
48.670-NA		Jogo de Juntas do Compressor de Ar Knorr LK 15 M.B.B. OM-366 93/...	
48.671-NA	4C50702	Junta do Compressor	1
48.672-NA	4C50700/1	Junta do Compressor	1
48.673-NA	4C50699	Junta do Compressor	1
48.948-NA	000.131.1579	Junta do Compressor	1
48.954-NA	000.131.1579	Junta do Compressor	1

TODAS AS PEÇAS SÃO FORNECIDAS INDIVIDUALMENTE

Compressor de Ar OM-355



48.963-NA



48.964-NA

CÓDIGO BRASMECK	CÓDIGO ORIGINAL	DESCRIÇÃO	QTDE.
48.949-NA	000.131.1679	Jogo de Juntas do Compressor de Ar OM-355	
48.963-NA		Junta do Compressor	1
48.964-NA		Junta do Compressor	1

TODAS AS PEÇAS SÃO FORNECIDAS INDIVIDUALMENTE

Compressor de Ar Knorr



48.954-NA

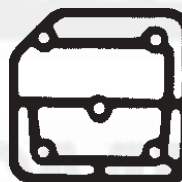

48.965-NA

CÓDIGO BRASMECK	CÓDIGO ORIGINAL	DESCRIÇÃO	QTDE.
48.960-NA		Jogo de Juntas do Compressor de Ar Knorr	
48.954-NA	000.131.1579	Junta do Compressor	1
48.965-NA		Junta do Compressor	1

TODAS AS PEÇAS SÃO FORNECIDAS INDIVIDUALMENTE

Compressor de Ar LK 15 – M.B.B. OM-366



48.671-BBS

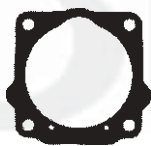

48.672-NA



48.673-NA



48.954-NA

CÓDIGO BRASMECK	CÓDIGO ORIGINAL	DESCRIÇÃO	QTDE.
48.968-NA		Jogo de Juntas do Compressor de Ar LK 15 – M.B.B. OM-366	
48.671-BBS	4C50702	Junta do Compressor	1
48.672-NA	4C50700/1	Junta do Compressor	1
48.673-NA	4C50699	Junta do Compressor	1
48.954-NA	000.131.1579	Junta do Cavalete Central do Compressor	1

TODAS AS PEÇAS SÃO FORNECIDAS INDIVIDUALMENTE

Compressor de Ar – M.B.B. OM-366



48.948-NA



48.954-NA

DESENHOS FORA DE ESCALA

CÓDIGO BRASMECK	CÓDIGO ORIGINAL	DESCRIÇÃO	QTDE.
48.969-NA		Jogo de Juntas do Compressor de Ar – M.B.B. OM-366	
48.948-NA	000.131.1479	Junta do Compressor	
48.954-NA	000.131.1579	Junta do Cavalete Central do Compressor	

TODAS AS PEÇAS SÃO FORNECIDAS INDIVIDUALMENTE

Compressor - LK 38



48.948-NA



48.954-NA

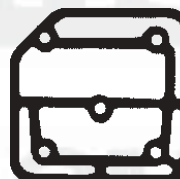

48.965-NA



48.967-NA

DESENHOS FORA DE ESCALA

CÓDIGO BRASMECK	CÓDIGO ORIGINAL	DESCRIÇÃO	QTDE.
48.930-NA		Jogo de Juntas do Compressor	
48.948-NA	000.131.1479	Junta do Compressor	1
48.954-NA	000.131.1579	Junta do Cavalete Central do Compressor	1
48.965-NA		Junta do Compressor	1
48.967-NA		Junta do Compressor	

TODAS AS PEÇAS SÃO FORNECIDAS INDIVIDUALMENTE

DESENHOS FORA DE ESCALA

CÓDIGO BRASMECK	CÓDIGO ORIGINAL	DESCRIÇÃO	QTDE.

TODAS AS PEÇAS SÃO FORNECIDAS INDIVIDUALMENTE

DESENHOS FORA DE ESCALA

Turbina MB 804 / 814



48.172-BBS



48.173-CH



48.376-NA



59.266-NA



59.376-NA



26,0x36,0x1,0-AL

CÓDIGO BRASMECK	CÓDIGO ORIGINAL	DESCRIÇÃO	QTDE.
48.194-DVM		Jogo de Juntas da Turbina MB 804 / 814	
48.172-BBS		Junta do Caracol da Turbina	1
48.173-CH		Junta da Base da Turbina	1
48.376-NA	1.671.153	Junta da Alimentação de Óleo	1
59.266-NA	139.472	Junta da Entrada de Óleo	2
59.376-NA	1.671.152	Junta do Cano de Retorno	1
		Arruela de Alumínio 26,0x36,0x1,0-AL	2

DESENHOS FORA DE ESCALA

Turbina Toyota



48.038-BBS



48.372-CH



48.373-CH



59.266-NA



59.376-NA



71.373-CH



14,0x20,0x1,5-AL



16,0x22,0x1,5-AL



26,0x36,0x1,0-AL

CÓDIGO BRASMECK	CÓDIGO ORIGINAL	DESCRIÇÃO	QTDE.
48.195-DVM		Jogo de Juntas da Turbina Toyota	
48.038-BBS		Junta do Coletor da Turbina	1
48.372-CH	352.098.0880	Junta do Caracol da Turbina	1
48.373-CH	344.098.7080	Junta da Base da Turbina	1
59.266-NA	139.472	Junta da Entrada de Óleo	1
59.376-NA	1.671.152	Junta do Cano de Retorno	1
71.373-CH		Junta da Turbina	1
		Arruela de Alumínio 14,0x20,0x1,5-AL	2
		Arruela de Alumínio 16,0x22,0x1,5-AL	2
		Arruela de Alumínio 26,0x36,0x1,0-AL	2

TODAS AS PEÇAS SÃO FORNECIDAS INDIVIDUALMENTE

DESENHOS FORA DE ESCALA

Turbina M.B.B. OM-364 / 709 / 712



48.173-CH



48.376-NA



59.265-NA



59.266-NA



59.376-NA



71.373-CH



26,0x36,0x1,0-AL

CÓDIGO BRASMECK	CÓDIGO ORIGINAL	DESCRIÇÃO	QTDE.
48.196-DVM		Jogo de Juntas da Turbina M.B.B. OM-364 / 709 / 712	
48.173-CH		Junta da Base da Turbina	1
48.376-NA	1.671.153	Junta da Alimentação de Óleo	1
59.265-NA	139.471	Junta do Tubo de Drenagem Inferior	1
59.266-NA	139.472	Junta da Entrada de Óleo	1
59.376-NA	1.671.152	Junta do Cano de Retorno	1
71.373-CH		Junta da Turbina	1
		Arruela de Alumínio 26,0x36,0x1,0-AL	2

DESENHOS FORA DE ESCALA

Turbina M.B.B. OM-314 / 608-D



48.338-NA



48.372-CH



48.379-CH



59.266-NA



59.376-NA



71.373-CH



14,0x20,0x1,5-AL

CÓDIGO BRASMECK	CÓDIGO ORIGINAL	DESCRIÇÃO	QTDE.
48.197-DVM		Jogo de Juntas da Turbina M.B.B. OM-314 / 608-D	
48.338-NA	314.016.0280	Junta do Tubo de Sucção do Óleo	1
48.372-CH	352.098.0880	Junta do Caracol da Turbina	1
48.379-CH	344.098.7080	Junta da Base da Turbina	1
59.266-NA	139.472	Junta da Entrada de Óleo	1
59.376-NA	1.671.152	Junta do Cano de Retorno	1
71.373-CH		Junta da Turbina	1
		Arruela de Alumínio	2
		Arruela de Alumínio 14,0x20,0x1,5-AL	4

TODAS AS PEÇAS SÃO FORNECIDAS INDIVIDUALMENTE

DESENHOS FORA DE ESCALA

Turbina Toyota Motor OM-364



48.222-BBS



48.376-NA



26,0x36,0x1,0-AL

CÓDIGO BRASMECK	CÓDIGO ORIGINAL	DESCRIÇÃO	QTDE.
48.198-DVM		Jogo de Juntas da Turbina Toyota Motor OM-364	
48.222-BBS	366.141.0280	Junta do Coletor de Admissão	2
48.376-NA	1.671.153	Junta da Alimentação de Óleo	1
		Arruela de Alumínio 26,0x36,0x1,0-AL	2

DESENHOS FORA DE ESCALA

Turbina M.B.B. 709



48.173-CH



48.174-CHA



48.222-BBS



48.331-CHA



59.376-NA



26,0x36,0x1,0-AL

CÓDIGO BRASMECK	CÓDIGO ORIGINAL	DESCRIÇÃO	QTDE.
48.199-BBS		Jogo de Juntas da Turbina M.B.B. 709	
48.173-CH		Junta da Base da Turbina	1
48.174-CHA		Junta da Turbina	1
48.222-BBS	366.141.0280	Junta do Coletor de Admissão	2
48.331-CHA	364.492.1080	Junta da Saída do Escape.	1
59.376-NA	1.671.152	Junta do Cano do Retorno	1
		Arruela de Alumínio 26,0x36,0x1,00-AL	2

TODAS AS PEÇAS SÃO FORNECIDAS INDIVIDUALMENTE

DESENHOS FORA DE ESCALA

Turbina M.B.B. OM-449/5



48.273-CH



48.274-CH



48.441-NA



48.465-NA



48.775-NA

CÓDIGO BRASMECK	CÓDIGO ORIGINAL	DESCRIÇÃO	QTDE.
48.496-DVM		Jogo de Juntas da Turbina M.B.B. OM-449/5	
48.273-CH		Junta da Base da Turbina	1
48.274-CH		Junta Caracol da Turbina	1
48.441-NA	617.187.0180	Junta da Entrada de Óleo	1
48.465-NA	917.003.040.003	Flange Aquecimento Conexão	1
48.775-NA	352.187.0080	Junta da Saída do Óleo	1

DESENHOS FORA DE ESCALA

Turbina M.B.B. OM-447/6



48.441-NA



48.465-NA



48.775-NA



59.263-CH



59.777-CH

CÓDIGO BRASMECK	CÓDIGO ORIGINAL	DESCRIÇÃO	QTDE.
48.497-DVM		Jogo de Juntas da Turbina M.B.B. OM-447/6	
48.441-NA	617.187.0180	Junta da Entrada de Óleo	1
48.465-NA	917.003.040.003	Flange Aquecimento Conexão	1
48.775-NA	352.187.0080	Junta da Saída do Óleo	1
59.263-CH	222.499	Junta do Caracol da Turbina	1
59.777-CH	139.616	Junta da Base da Turbina	1

TODAS AS PEÇAS SÃO FORNECIDAS INDIVIDUALMENTE

DESENHOS FORA DE ESCALA

Turbina M.B.B. OM-352 / 366 KKK Lacon / Garret



48.372-CH



48.373-CH



48.374-NA



48.375-NA



59.272-NA



16,0x22,0x1,5-AL



14,0x20,0x1,5-AL

CÓDIGO BRASMECK	CÓDIGO ORIGINAL	DESCRIÇÃO	QTDE.
48.896-DVM		Jogo de Juntas da Turbina M.B.B. OM-352 / 366 KKK Lacon / Garret	
48.372-CH	352.098.0880	Junta do Caracol da Turbina	1
48.373-CH	344.098.7080	Junta da Base da Turbina	1
48.374-NA		Junta da Turbina	1
48.375-NA		Junta do Cano de Retorno	1
59.272-NA		Junta do Cano de Lubrificação	1
		Arruela de Alumínio 16,0x22,0x1,5-AL	4
		Arruela de Alumínio 14,0x20,0x1,5-AL	4

DESENHOS FORA DE ESCALA

M.B.B. OM-352 / 366 KKK Lacon / Garret



48.372-CH



48.379-CH



48.374-NA



48.375-NA



59.272-NA



16,0x22,0x1,5-AL



14,0x20,0x1,5-AL

CÓDIGO BRASMECK	CÓDIGO ORIGINAL	DESCRIÇÃO	QTDE.
48.897-DVM		Jogo de Juntas da Turbina M.B.B. OM-352 / 366 KKK Lacon / Garret	
48.372-CH	352.098.0880	Junta do Caracol da Turbina	1
48.37-CH	344.098.7080	Junta da Base da Turbina	1
48.374-NA		Junta da Turbina	1
48.375-NA		Junta do Cano de Retorno	1
59.272-NA		Junta do Cano de Lubrificação	1
		Arruela de Alumínio 16,0x22,0x1,5-AL	4
		Arruela de Alumínio 14,0x20,0x1,5-AL	4

TODAS AS PEÇAS SÃO FORNECIDAS INDIVIDUALMENTE

Radiador de Óleo M.B.B. 709 / 710



48.631-NA



48.369-NA

CÓDIGO BRASMECK	CÓDIGO ORIGINAL	DESCRIÇÃO	QTDE.
48.368-NA		Jogo de Juntas do Radiador de Óleo M.B.B. 709 / 710	
48.369-NA		Junta do Radiador	1
48.631-NA		Junta do Radiador	1

TODAS AS PEÇAS SÃO FORNECIDAS INDIVIDUALMENTE

Refrigeração de Óleo M.B.B. OM-366 / 366 A



48.437-PS



48.530-PS



48.539-PS

CÓDIGO BRASMECK	CÓDIGO ORIGINAL	DESCRIÇÃO	QTDE.
48.444-PS	344.586.7018	Jogo de Juntas de Refrigeração de Óleo M.B.B. OM-366 / 366 A	
48.437-PS	362.188.0080	Junta do Trocador de Calor do Óleo	1
48.530-PS	312.188.1479	Junta da Tampa do Trocador de Calor	1
48.539-PS	312.188.1579	Arruela da Tampa do Radiador de Óleo	4

TODAS AS PEÇAS SÃO FORNECIDAS INDIVIDUALMENTE

Cano D' Água M.B.B. OM-366



48.341-NA



48.446-NA



CÓDIGO BRASMECK	CÓDIGO ORIGINAL	DESCRIÇÃO	QTDE.
48.499-NA		Jogo de Juntas do Cano D' Água M.B.B. OM-366	
48.341-NA	352.203.0680	Junta do Cavalete D' Água	2
48.446-NA	366.203.0080	Junta do Termostato	1
	0.039.975.748	Anel de Borracha	2

TODAS AS PEÇAS SÃO FORNECIDAS INDIVIDUALMENTE

Caixa de Direção MEC



48.892-NA



DESENHOS FORA DE ESCALA

CÓDIGO BRASMECK	CÓDIGO ORIGINAL	DESCRIÇÃO	QTDE.
48.704-DVM		Jogo de Juntas da Caixa de Direção MEC	
48.892-NA		Junta	1
		Juntas diversas	6

TODAS AS PEÇAS SÃO FORNECIDAS INDIVIDUALMENTE

Bomba D' Água M.B.B. OM-352 A



48.337-NA



48.838-NA



48.893-NA

DESENHOS FORA DE ESCALA

CÓDIGO BRASMECK	CÓDIGO ORIGINAL	DESCRIÇÃO	QTDE.
48.830-NA		Jogo de Juntas da BBA D' Água M.B.B. OM-352 A	
48.337-NA	352.201.0480	Junta da BBA D' Água	1
48.838-NA	352.201.0980	Junta do Suporte da BBA D' Água	1
48.893-NA	352.201.1280	Junta da BBA D' Água	1

TODAS AS PEÇAS SÃO FORNECIDAS INDIVIDUALMENTE

Refrigeração de Óleo M.B.B. OM-352 / 352 A



48.530-PS



48.531-PS



48.539-PS

DESENHOS FORA DE ESCALA

CÓDIGO BRASMECK	CÓDIGO ORIGINAL	DESCRIÇÃO	QTDE.
48.868-PS	044.586.0018	Jogo de Juntas de Refrigeração de Óleo M.B.B. OM-352 / 352 A	
48.530-PS	312.188.1479	Junta da Refrigeração de Óleo	1
48.531-PS	312.188.0179	Junta da Refrigeração de Óleo	1
48.539-PS	312.188.1579	Arruela da Tampa do Radiador de Óleo	4

TODAS AS PEÇAS SÃO FORNECIDAS INDIVIDUALMENTE

Refrigeração de Água M.B.B. OM-314 / 352 / 352 A / 364 / 366 / 366 A



48.341-NA



48.346-NA



48.347-NA



48.448-NA

CÓDIGO BRASMECK	CÓDIGO ORIGINAL	DESCRIÇÃO	QTDE.
48.899-NA		Jg. de Jtas. de Refrig. de Água M.B.B. OM-314/352/352 A/364/366/366 A	
48.341-NA	352.203.0680	Junta do Cavalete D'Água	3
48.346-NA	352.203.0480	Junta do Termostato	1
48.347-NA	352.203.0080	Junta do Alojamento da Válvula Termostática	2
48.448-NA	352.203.0780	Junta do Termostato	1

TODAS AS PEÇAS SÃO FORNECIDAS INDIVIDUALMENTE

Adaptação para Turbinamento OM-352



48.822-CH



48.931-CHA

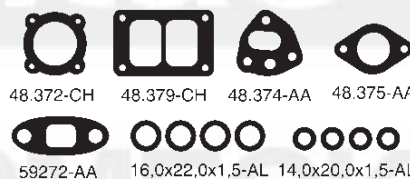

48.897-DVM

CÓDIGO BRASMECK	CÓDIGO ORIGINAL	DESCRIÇÃO	QTDE.
48.895-DVM		Conjunto Adaptação p/ Turbinamento OM-352	
48.822-CH	352.142.0280	Jogo de Juntas do Escape.	2
48.897-DVM		Jogo de Juntas da Turbina	1
48.931-CHA	344.492.0080	Junta da Saída do Escape.	1

TODAS AS PEÇAS SÃO FORNECIDAS INDIVIDUALMENTE

Adaptação para Turbinamento OM-366



48.221-CH



48.622-CHA

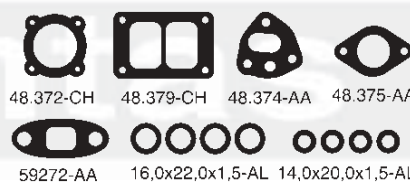

48.897-DVM

CÓDIGO BRASMECK	CÓDIGO ORIGINAL	DESCRIÇÃO	QTDE.
48.898-DVM		Conjunto Adaptação p/ Turbinamento OM-366	
48.221-CH	366.142.0180	Junta do Coletor do Escape.	1
48.622-CHA	350.492.0080	Junta da Saída do Escape.	1
48.897-DVM		Jogo de Juntas da Turbina	1

TODAS AS PEÇAS SÃO FORNECIDAS INDIVIDUALMENTE

Coletor de Admissão OM-355/5



48.920-BBS



48.922-BBS

CÓDIGO BRASMECK	CÓDIGO ORIGINAL	DESCRIÇÃO	QTDE.
48.923-BBS		Jogo de Juntas do Coletor de Admissão OM-355/5	
48.920-BBS	345.141.0080	Junta do Coletor de Admissão	1
48.922-BBS	346.141.0180	Junta do Coletor de Admissão	1

TODAS AS PEÇAS SÃO FORNECIDAS INDIVIDUALMENTE

Coletor de Admissão OM-355/6



48.922-BBS

CÓDIGO BRASMECK	CÓDIGO ORIGINAL	DESCRIÇÃO	QTDE.
48.924-BBS		Jogo de Juntas do Coletor de Admissão OM-355/6	
48.922-BBS	346.141.0180	Junta do Coletor de Admissão	2

TODAS AS PEÇAS SÃO FORNECIDAS INDIVIDUALMENTE

Coletor de Escape OM-355/5



48.921-CH

CÓDIGO BRASMECK	CÓDIGO ORIGINAL	DESCRIÇÃO	QTDE.
48.955-CH		Jogo de Juntas do Coletor de Escape OM-355/5	
48.921-CH	345.142.7060	Junta do Coletor de Escape.	5

TODAS AS PEÇAS SÃO FORNECIDAS INDIVIDUALMENTE

DESENHOS FORA DE ESCALA

DESENHOS FORA DE ESCALA

DESENHOS FORA DE ESCALA

Coletor de Escape OM-355/6



48.921-CH

DESENHOS FORA DE ESCALA

CÓDIGO BRASMECK	CÓDIGO ORIGINAL	DESCRIÇÃO	QTDE.
48.961-CH		Jogo de Juntas do Coletor de Escape OM-355/6	
48.921-CH	345.142.7060	Junta do Coletor de Escape.	6

TODAS AS PEÇAS SÃO FORNECIDAS INDIVIDUALMENTE

Refrigeração de Água M.B.B. OM-355/5/6



48.939-NA



48.940-NA



48.941-NA

DESENHOS FORA DE ESCALA

CÓDIGO BRASMECK	CÓDIGO ORIGINAL	DESCRIÇÃO	QTDE.
48.999-NA		Jogo de Juntas de Refrigeração de Água M.B.B. OM-355/5/6	
48.939-NA	326.997.0149	Junta Cavalete da BBA D'Água	6
48.940-NA	355.201.0080	Junta do Arrefecimento do Motor	2
48.941-NA	355.203.0080	Junta da Válvula Termostática ao Bloco	1

TODAS AS PEÇAS SÃO FORNECIDAS INDIVIDUALMENTE

DESENHOS FORA DE ESCALA

CÓDIGO BRASMECK	CÓDIGO ORIGINAL	DESCRIÇÃO	QTDE.

TODAS AS PEÇAS SÃO FORNECIDAS INDIVIDUALMENTE



48.051-CT



48.051-GV



48.150-CT



48.150-GV



48.242-CB



48.242-CT



48.242-GV



48.243-GV



48.243-PS



48.244-CT



48.244-GV



48.244-NA



48.245-CB



48.245-CT



48.245-GV



48.248-CB



48.248-CT



48.248-GV



48.343-NA



48.348-NA



48.423-CH

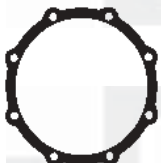

48.442-CT



48.442-GV



48.443-CT



48.443-GV



48.551-PS



48.627-NA



48.629-NA



48.645-GV



48.647-CT



48.647-GV



48.648-CT

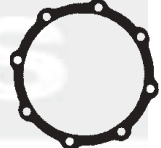

48.648-GV



48.649-NA

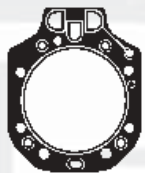

48.701-OIL



48.722-CHA



48.723-BBS



48.724-NA



48.725-NA



48.776-BO



48.822-CHA

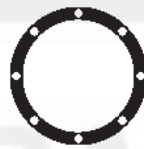

48.848-CT



48.848-GV



48.898-BBS



48.952-CT

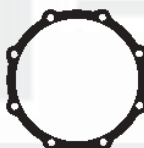

48.952-GV



48.954-CT



48.986-CT



48.986-NA

CÓDIGO BRASMECK	CÓDIGO ORIGINAL	DESCRIÇÃO
48.051-CT	312.356.1079	Junta do Semi Eixo M.B.B. L-321 / 1321 (8 furos)
48.051-GV	312.356.1079	Junta do Semi Eixo M.B.B. L-321 / 1321 (8 furos)
48.150-CT	TMJ-501.211	Junta do Semi Eixo M.B.B.
48.150-GV	TMJ-501.211	Junta do Semi Eixo M.B.B.
48.242-CB		Junta do Cubo de Roda Truck Carreta Randon 1981
48.242-CT		Junta do Cubo de Roda Truck Carreta Randon 1981
48.242-GV		Junta do Cubo de Roda Truck Carreta Randon 1981
48.243-GV		Junta da Balança M.B.B. 2013
48.243-PS		Junta da Balança M.B.B. 2013
48.244-CT		Junta do Semi Eixo M.B.B. 1313 / 1513 / 2013
48.244-GV		Junta do Semi Eixo M.B.B. 1313 / 1513 / 2013
48.244-NA		Junta do Semi Eixo M.B.B. 1313 / 1513 / 2013
48.245-CB		Junta do Cubo Truck Randon Iderol até 1980
48.245-CT		Junta do Cubo Truck Randon Iderol até 1980
48.245-GV		Junta do Cubo Truck Randon Iderol até 1980
48.248-CB		Junta do Cubo de Roda Carreta Randon (4 furos) Moderno
48.248-CT		Junta do Cubo de Roda Carreta Randon (4 furos) Moderno
48.248-GV		Junta do Cubo de Roda Carreta Randon (4 furos) Moderno
48.343-NA		Junta do Cabeçote Compressor Moderno (Grafitada)
48.348-NA	322.325.0080	Junta da Calota 3º Eixo
48.423-CH	442.141.0480	Junta de Admissão
48.442-CT	317.356.0080	Junta do Semi Eixo Cubo Traseiro 0-371
48.442-GV	317.356.0080	Junta do Semi Eixo Cubo Traseiro 0-371
48.443-CT	389.334.0080	Junta do Semi Eixo
48.443-GV	389.334.0080	Junta do Semi Eixo
48.525-NA	457.098.0080	Junta do Tubo de Admissão M.B.B. OM-457 – Eletrônico
48.551-PS	322.356.1079	Junta do Semi Eixo Traseiro (16 furos)
48.627-NA		Junta da Distribuição M.B.B. OF 1620 até 2.000
48.629-NA		Junta da Distribuição M.B.B. OF 1620 após 2.000 Motor Euro 2
48.645-GV	389.325.0280	Junta da Balança do Truck L-2325
48.647-CT	383.325.0080	Junta da Balança do Truck M.B.B. L-2325
48.647-GV	383.325.0080	Junta da Balança do Truck M.B.B. L-2325
48.648-CT	317.356.0080	Junta do Semi Eixo OF-1620
48.648-GV	317.356.0080	Junta do Semi Eixo OF-1620
48.649-NA	650.356.0080	Junta do Cubo Traseiro M.B.B. 1935 – 1985
48.701-OIL		Junta do Cabeçote OM-355 para 1 cil
48.722-CHA	A906.142.0280	Junta Coletor Escape. M.B.B. 924
48.723-BBS	A906.141.0180	Junta Coletor Admissão M.B.B. 924
48.724-NA	A906.201.0080	Junta BBA D' Água M.B.B. 924
48.725-NA	A906.203.0180	Junta da Carcaça Valv. Termostática M.B.B. 924
48.776-BO	407.131.0580	Junta da Tampa do Compressor Knorr 1935
48.822-CHA	352.142.0280	Jogo de Juntas do Escape OM 352
48.848-CT	322.356.0179	Junta do Semi Eixo 1313
48.848-GV	322.356.0179	Junta do Semi Eixo 1313
48.898-BBS		Junta do Semi Eixo (10 furos)
48.952-CT	327.356.0180	Junta do Semi Eixo M.B.B. OM-355/5/6
48.952-GV	327.356.0180	Junta do Semi Eixo M.B.B. OM-355/5/6
48.954-CT	000.131.1579	Junta do Cavalete Central do Motor OM-457 Eletrônico 2538/2638
48.986-CT		Junta da Distribuição Caixa de Câmbio Z.F.
48.986-NA		Junta da Distribuição Caixa de Câmbio Z.F.

TODAS AS PEÇAS SÃO FORNECIDAS INDIVIDUALMENTE



48.050-NA



48.053-NA



48.104-NA



48.153-NA



48.154-CB

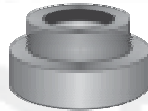

48.253-NA



48.353-NA

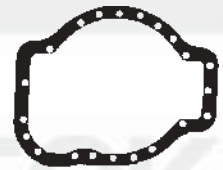

48.453-NA



48.553-NA

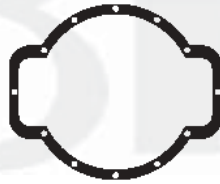

48.853-NA



48.950-NA



48.951-NA

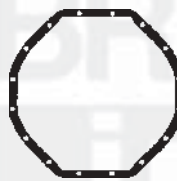

48.953-NA

CÓDIGO BRASMECK	CÓDIGO ORIGINAL	DESCRIÇÃO
48.050-NA	312.351.1080	Junta da Tampa do Diferencial L-312
48.053-NA	321.351.0080	Junta da Tampa do Diferencial L-321
48.104-NA	385.351.0080	Junta da Tampa do Diferencial HLS 1620 / OF 1620
48.153-NA		Junta da Tampa do Diferencial do Jeep Toyota
48.154-CB		Junta da Tampa do Diferencial do Jeep Toyota
48.253-NA	031.353.0280	Junta da Tampa do Diferencial Tinkão M.B.B. LPO 1520
48.353-NA	324.351.0080	Junta da Tampa do Diferencial do L-608-D
48.453-NA	383.351.0280	Junta da Tampa do Diferencial Traseiro 2219
48.553-NA	322.351.0180	Junta da Tampa do Diferencial LPO-322
48.853-NA	302.351.0180	Junta da Tampa do Diferencial 1313/1513/2013
48.950-NA	383.351.0480	Junta da Tampa do Diferencial 2219
48.951-NA	383.351.0380	Junta da Tampa do Diferencial OM-355/6 - LS-1924
48.953-NA	317.351.0280	Junta da Tampa do Diferencial OM-355/5

TODAS AS PEÇAS SÃO FORNECIDAS INDIVIDUALMENTE



TECNOLOGIA ORIGINAL EM PEÇAS DE REPOSIÇÃO

BRASMECK
juntas

BRASMECK
juntas

BRASMECK
juntas

MWM

BRASMECK
juntas

BRASMECK
juntas

M.W.M D-225 / 3 CILINDROS

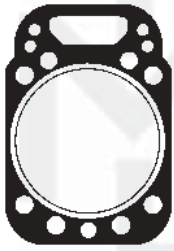

71.601-OIL



71.072-NA



71.221-BBS



71.222-BBS



71.226-CB

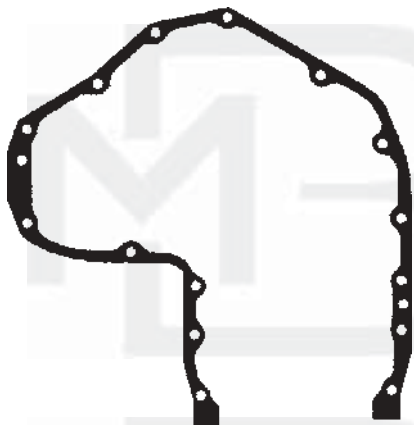

71.227-NA



71.228-NA



71.232-NA



71.229-NA



71.233-NA

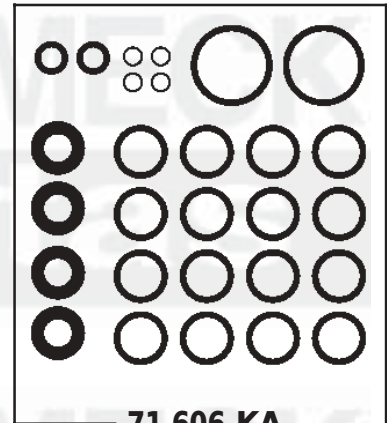

71.606-KA

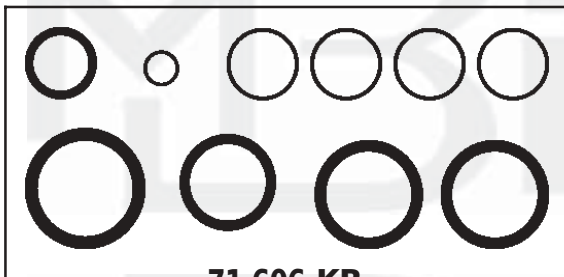

71.606-KB



71.612-BO



71.616-NA



71.621-CHA



71.630-NA



71.631-NA



71.634-NA



71.635-BBS



71.636-NA



71.637-NA



71.639-NA



71.641-NA



71.653-NA



71.659-BBS



71.835-NA

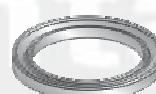

9.0803-S

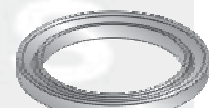

9.1917-S

DESENHOS FORA DE ESCALA

M.W.M D-225 / 4 CILINDROS

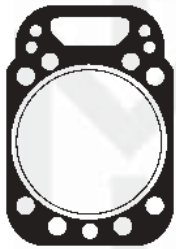

71.601-OIL



71.072-NA



71.221-BBS



71.222-BBS



71.226-CB

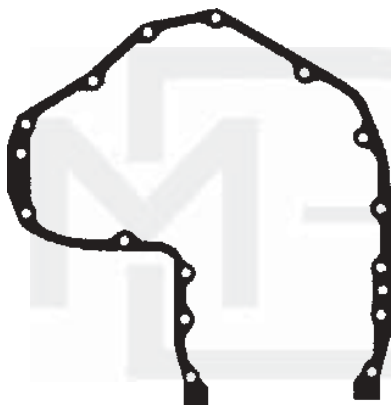

71.227-NA



71.228-NA



71.229-NA



71.232-NA



71.233-NA



71.612-BO



71.621-CHA



71.630-NA



71.631-NA



71.635-BBS



71.636-NA



71.637-NA



71.639-NA



71.641-NA



71.653-NA

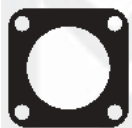

71.659-BBS

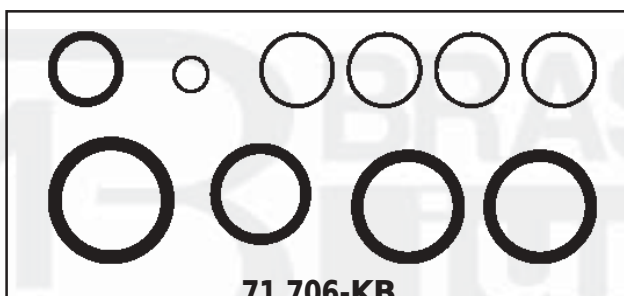

71.706-KB

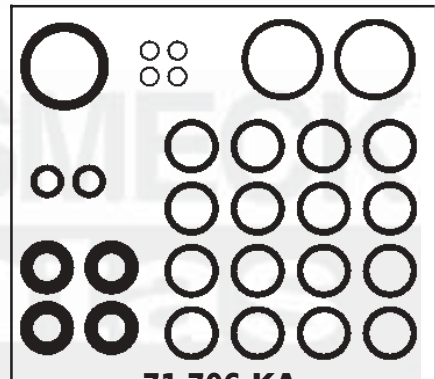

71.706-KA



71.716-NA



71.734-NA



71.834-NA



71.835-NA



9.0803-S



9.1917-S

M.W.M D-225 / 6 CILINDROS

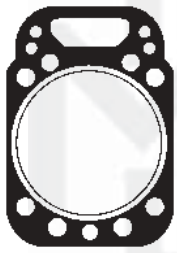

71.601-OIL



71.072-NA



71.221-BBS



71.222-BBS



71.226-CB

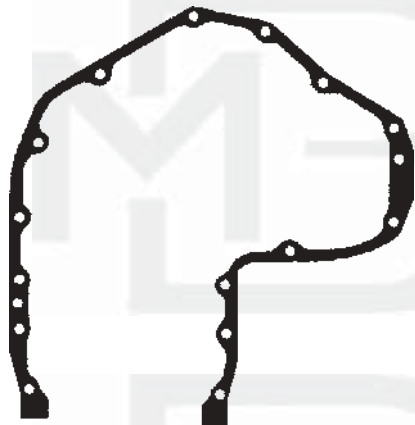

71.227-NA



71.228-NA



71.229-NA



71.232-NA



71.233-NA



71.612-BO



71.621-CHA



71.630-NA



71.631-NA



71.635-BBS



71.636-NA



71.637-NA



71.641-NA



71.653-NA



71.659-BBS

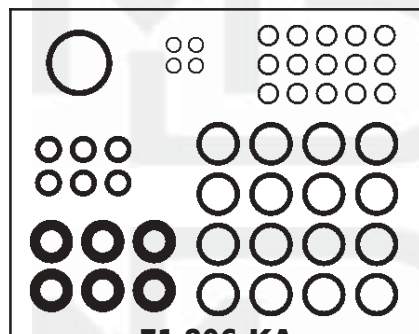

71.806-KA

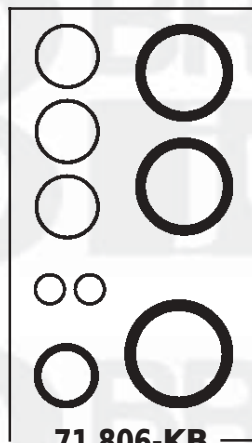

71.806-KB



71.816-NA



71.834-NA



71.835-NA



71.836-NA



71.855-NA



71.856-NA



71.857-NA



9.0803-S



9.1917-S

DESENHOS FORA DE ESCALA

M.W.M D-226 / 4 CILINDROS

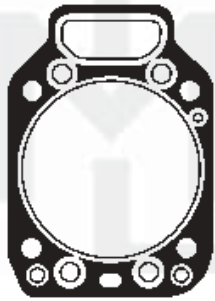

71.201-OIL



71.072-NA

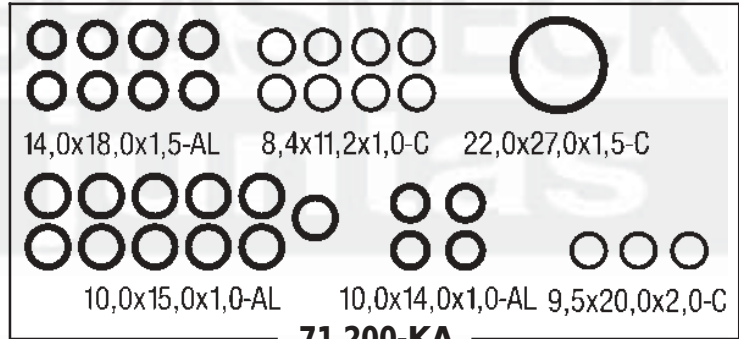

14,0x18,0x1,5-AL 8,4x11,2x1,0-C 22,0x27,0x1,5-C

10,0x15,0x1,0-AL 10,0x14,0x1,0-AL 9,5x20,0x2,0-C

71.200-KA



46,0x3,0-S



14,4x3,3-B



20,6x3,4-S



8,5x2,0-B



31,4x3,6-B



21,6x32,4x7,5-B



6,0x1,6-B

71.200-KB



71.221-BBS



71.222-BBS



71.226-CB

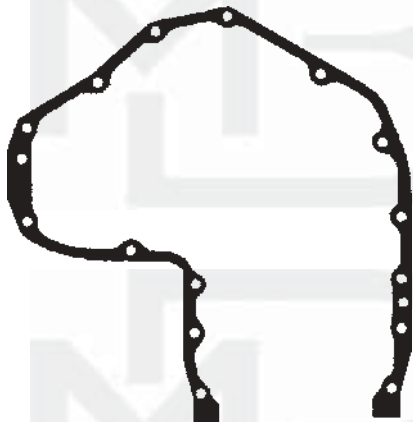

71.227-NA



71.228-NA



71.229-NA



71.232-NA



71.233-NA



71.234-NA



71.235-NA



71.236-NA



71.263-CU



71.612-BO



71.630-NA



71.635-NA



71.659-BBS



71.716-NA



71.835-NA



9.0803-S



9.1917-S

DESENHOS FORA DE ESCALA

M.W.M D-229 / 3 CILINDROS

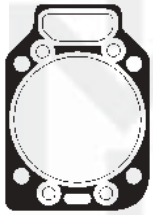

71.101-OIL



71.072-NA

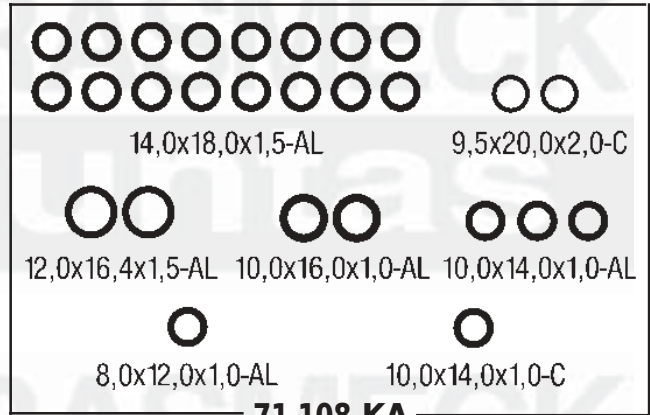

71.108-KA

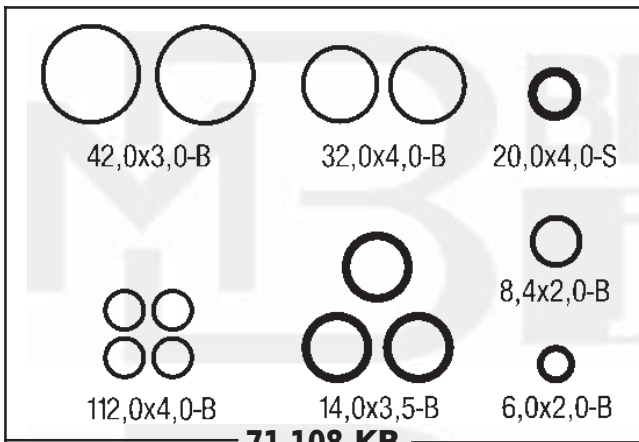

71.108-KB



71.126-CB



71.163-CA



71.221-BBS



71.222-BBS

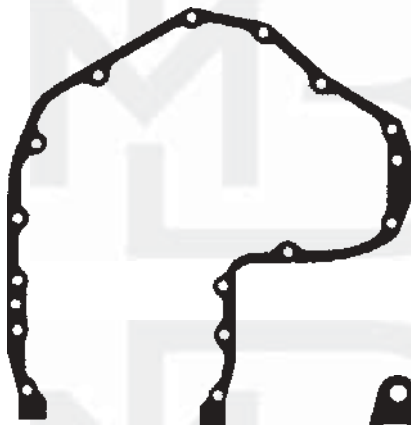

71.227-NA



71.228-NA



71.229-NA



71.232-NA



71.233-NA



71.234-NA



71.235-NA



71.612-BO



71.616-NA



71.621-CHA



71.630-NA



71.635-NA



71.636-NA



71.637-NA



71.659-BBS



71.835-NA

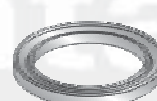

9.0803-S



9.1917-S

DESENHOS FORA DE ESCALA

M.W.M D-229 / 4 CILINDROS

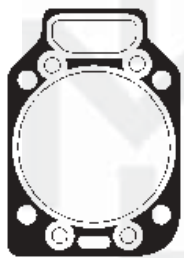

71.101-OIL

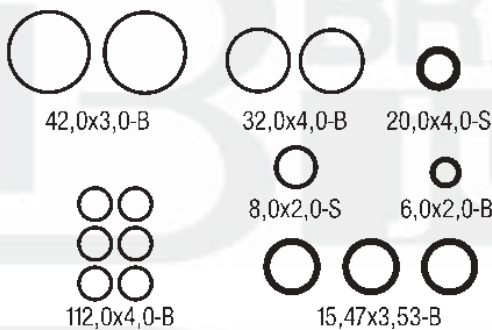

71.107-KA

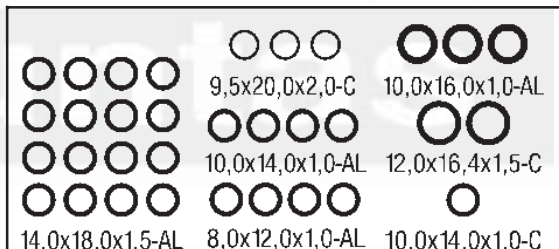

71.107-KB



71.126-CB



71.163-CU



71.221-BBS



71.222-BBS

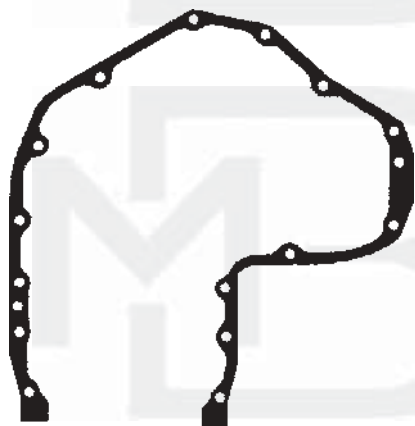

71.227-NA



71.228-NA



71.229-NA



71.232-NA



71.233-NA



71.234-NA



71.235-NA



71.612-BO



71.621-CHA



71.630-NA



71.635-NA



71.636-NA



71.637-NA



71.659-BBS



71.716-NA



71.834-NA



71.835-NA



9.0803-S



9.1917-S

DESENHOS FORA DE ESCALA

M.W.M D-229 / 4 CILINDROS - Turbinado

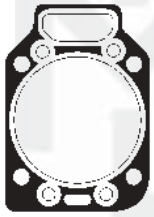

71.101-OIL 71.072-NA

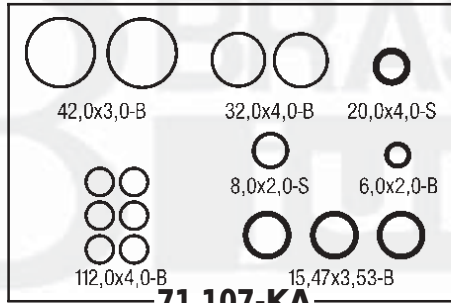

71.107-KA

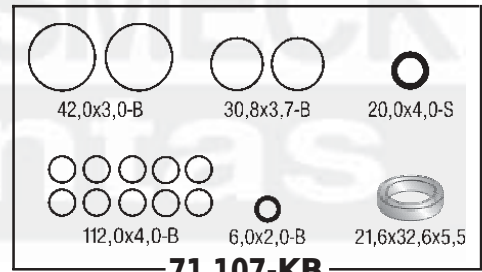

71.107-KB

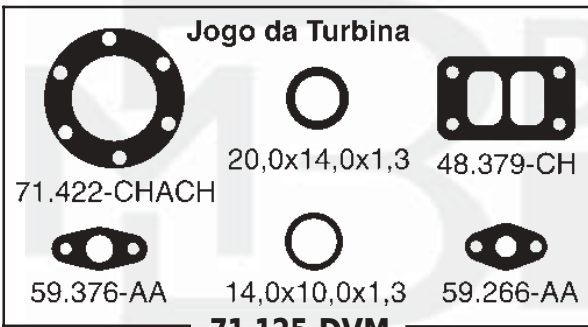

Jogo da Turbina

71.422-CHACH

20,0x14,0x1,3

48.379-CH

59.376-AA

14,0x10,0x1,3

59.266-AA

71.125-DVM



71.126-CB



71.163-CU



71.221-BBS



71.221-CHACH



71.222-BBS

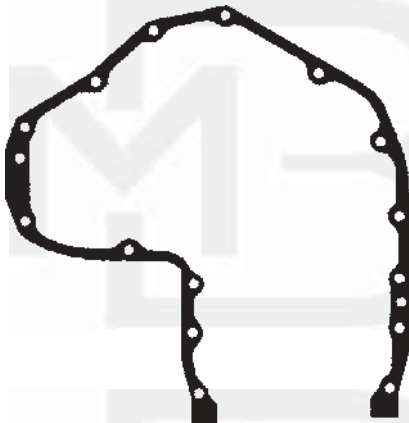

71.227-NA



71.228-NA



71.229-NA



71.232-NA



71.233-NA



71.234-NA



71.235-NA



71.236-NA

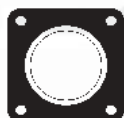

71.423-BBS



71.432-NA



71.434-NA



71.612-BO



71.621-CHA



71.630-NA



71.635-BBS



71.636-NA



71.637-NA



71.659-BBS



71.716-NA



71.834-NA



71.835-NA

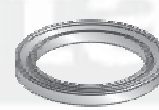

9.0803-S



9.1917-S

DESENHOS FORA DE ESCALA

M.W.M D-229 / 6 CILINDROS

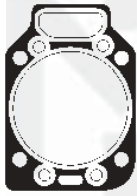

71.101-OIL



71.072-NA

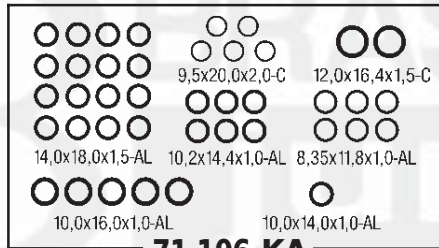

71.106-KA

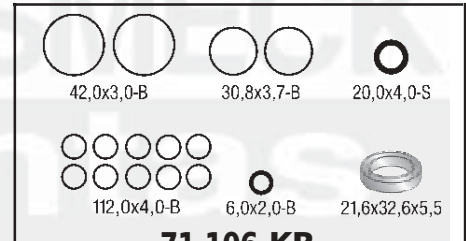

71.106-KB



71.126-BO



71.126-CB



71.163-CU



71.221-BBS



71.222-BBS

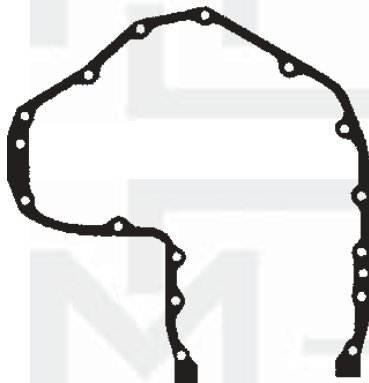

71.227-NA



71.228-NA



71.229-NA



71.232-NA



71.233-NA



71.234-NA



71.235-NA

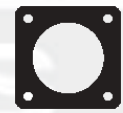

71.236-NA



71.612-BO



71.621-CHA



71.630-NA



71.635-NA



71.636-NA



71.637-NA



71.659-BBS

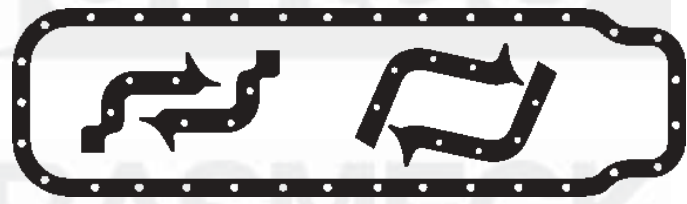

71.816-NA



71.835-NA



9.0803-S

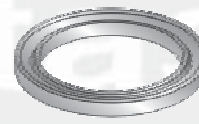

9.1917-S

DESENHOS FORA DE ESCALA

M.W.M D-229 / 6 CILINDROS - Turbinado

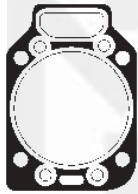

71.101-OIL



71.072-NA

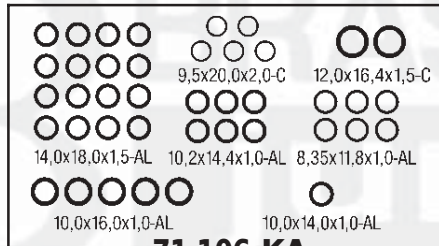

71.106-KA

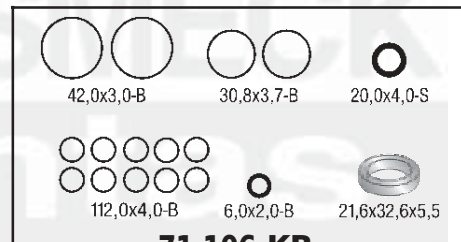

71.106-KB

Jogo da Turbina



71.422-CHACH



20,0x14,0x1,3



48.379-CH



59.376-AA



14,0x10,0x1,3



59.266-AA

71.125-DVM



71.126-CB



71.163-CU



71.221-BBS



71.221-CHACH



71.222-BBS

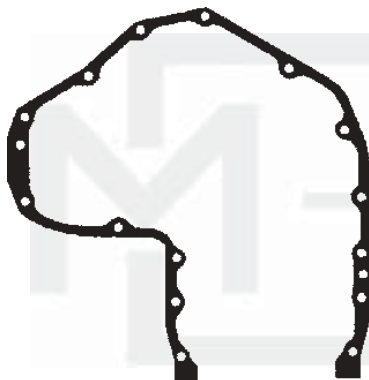

71.227-NA



71.228-NA



71.229-NA



71.232-NA



71.233-NA



71.234-NA



71.235-NA



71.236-NA



71.423-BBS



71.432-NA



71.434-NA



71.612-BO



71.621-CHA



71.630-NA



71.635-NA



71.636-NA



71.637-NA



71.659-BBS



71.816-NA



71.835-NA



9.0803-S



9.1917-S

MOTOR 410-4 SÉRIE X-10 – VANS VOLARE



71.102-OIL



70.035-NA

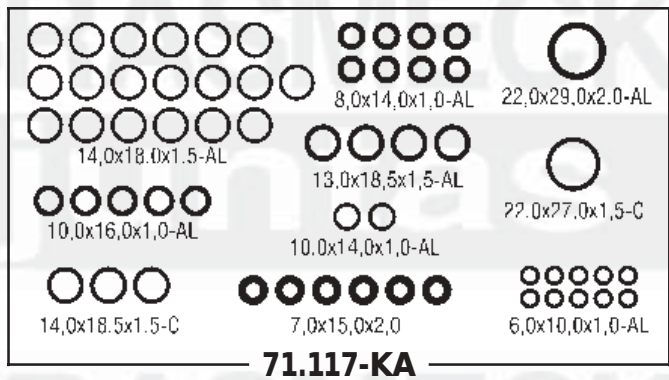

71.117-KA

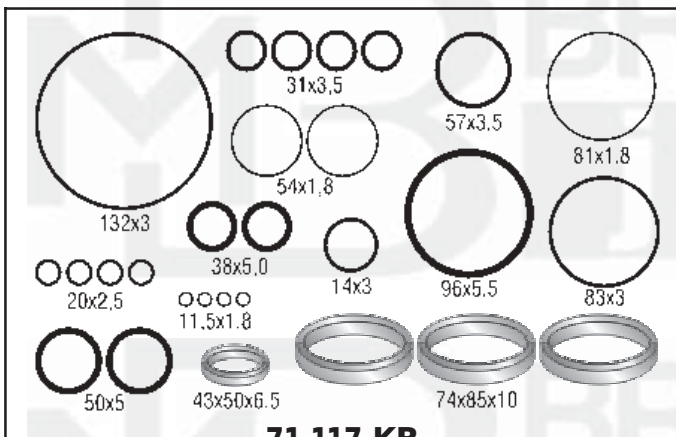

71.117-KB

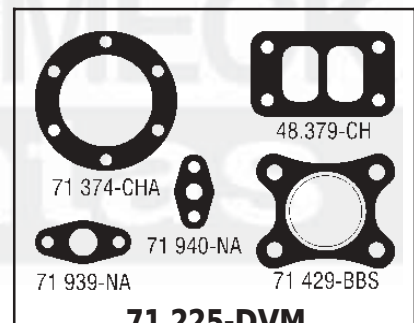

71.225-DVM



71.143-BBS



71.326-BO

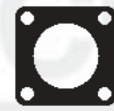

71.437-NA



71.438-BBS



71.441-NA



71.442-NA



71.443-NA



71.444-NA



71.446-NA



71.543-NA

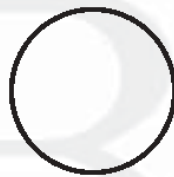

71.612-BO



71.642-BBS



71.642-CHA

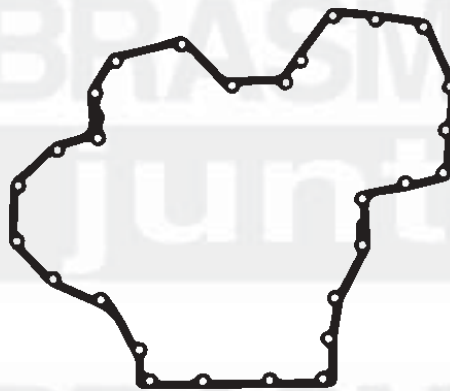

71.727-NA

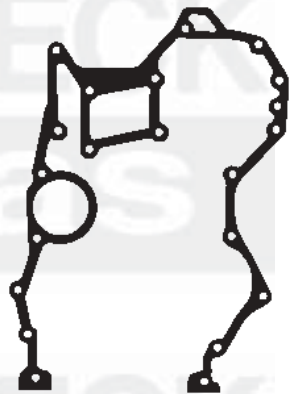

71.827-NA

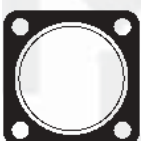

71.859-BBS



71.916-NA



9.2871-S



9.2872-S



9.2927-S

DESENHOS FORA DE ESCALA

MOTOR 610-6 SÉRIE X-10



71.102-OIL

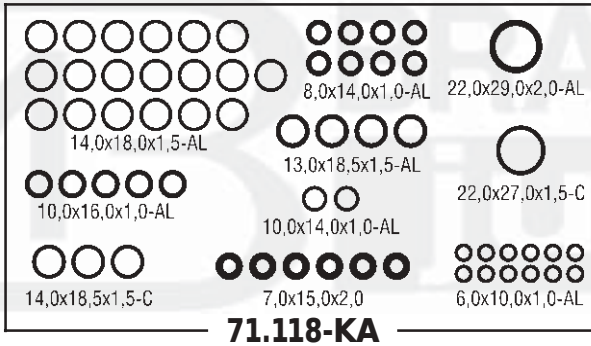

71.118-KA

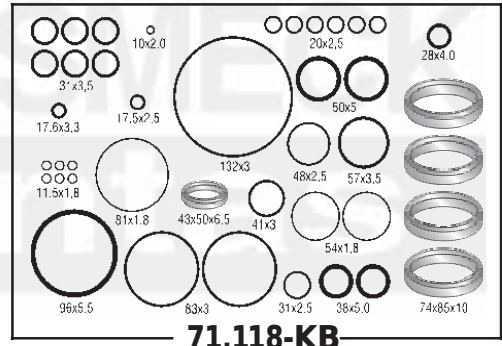

71.118-KB

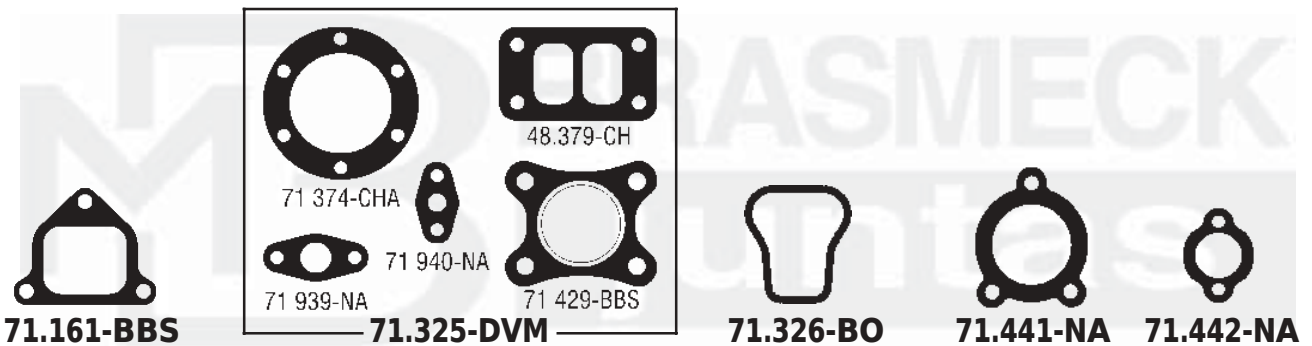

71.161-BBS

71.325-DVM

71.326-BO

71.441-NA

71.442-NA

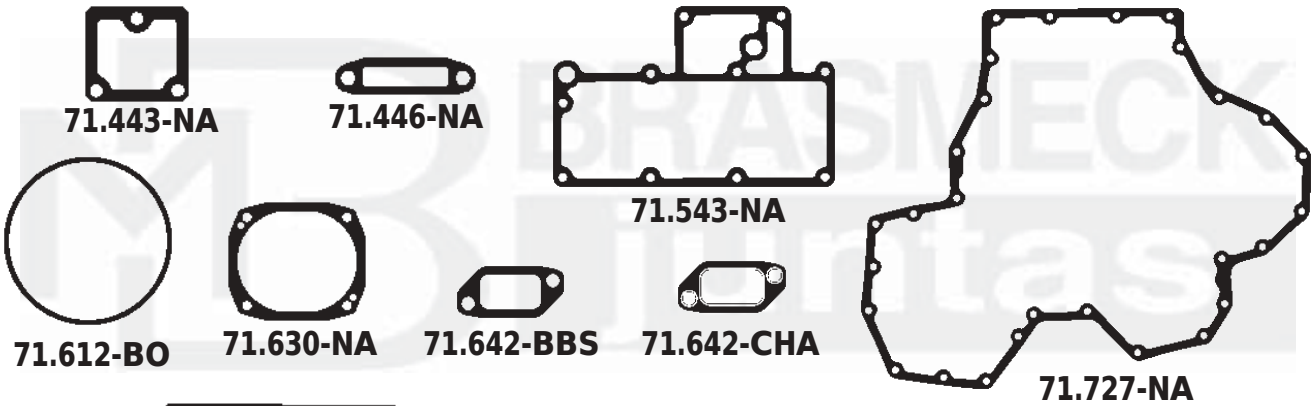

71.443-NA

71.446-NA

71.543-NA

71.612-BO

71.630-NA

71.642-BBS

71.642-CHA

71.727-NA

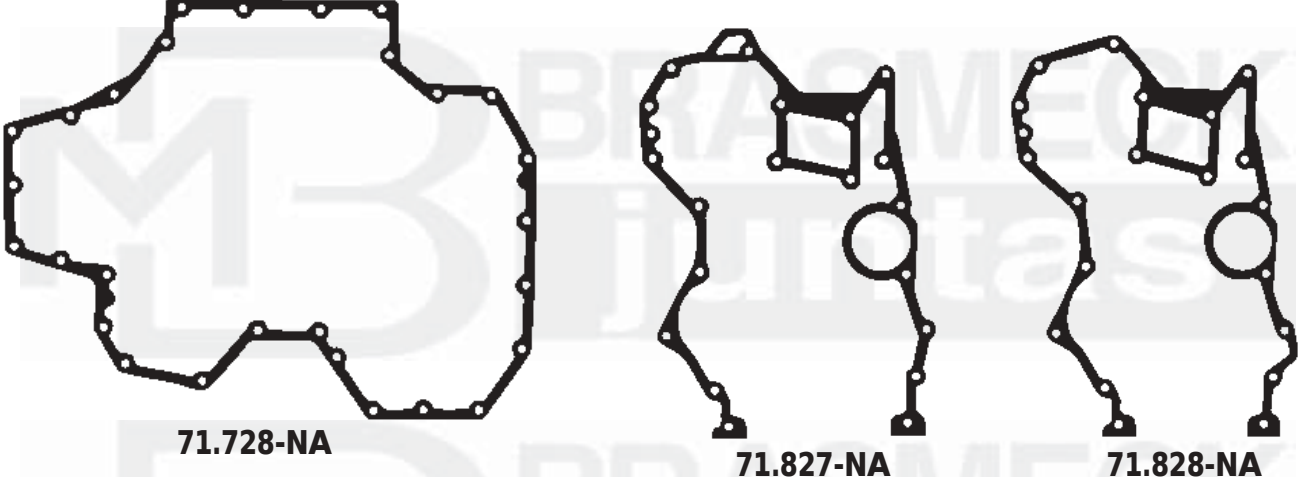

71.728-NA

71.827-NA

71.828-NA



71.917-NA

9.2871-S

9.2872-S

9.2927-S

DESENHOS FORA DE ESCALA

SPRINT 4 CILINDROS



71.002-OIL

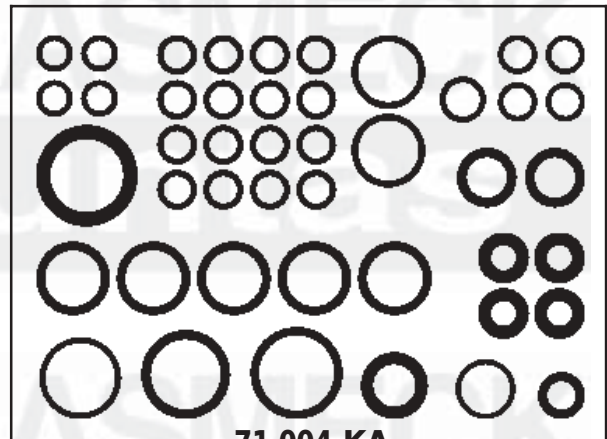

71.004-KA

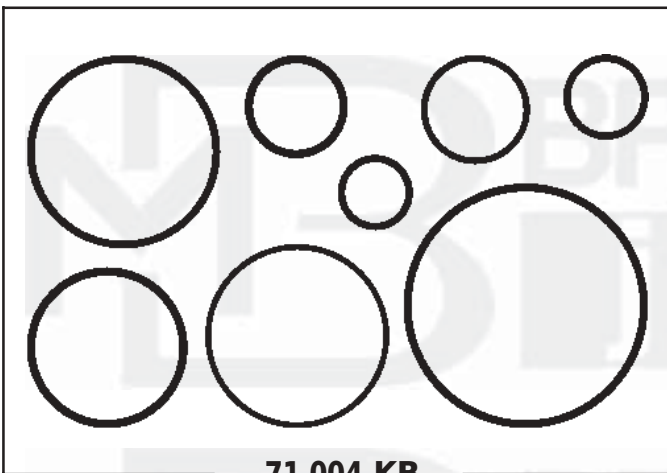

71.004-KB



71.071-CB



71.073-CHA



71.074-NA



71.076-BO



71.077-NA

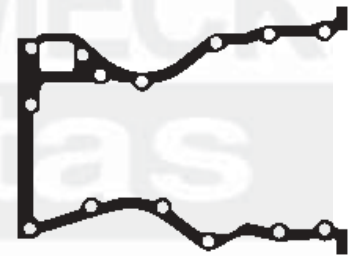

71.078-PS



71.079-NA



71.080-NA



71.082-NA



71.091-NA



71.095-S



71.096-NA



71.098-S



71.099-S

DESENHOS FORA DE ESCALA

SPRINT 6 CILINDROS



71.003-OIL

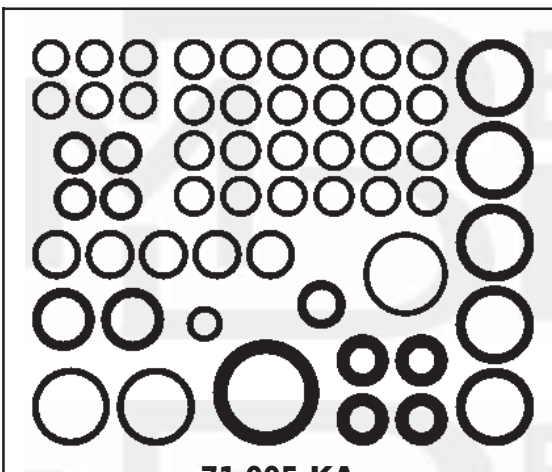

71.005-KA

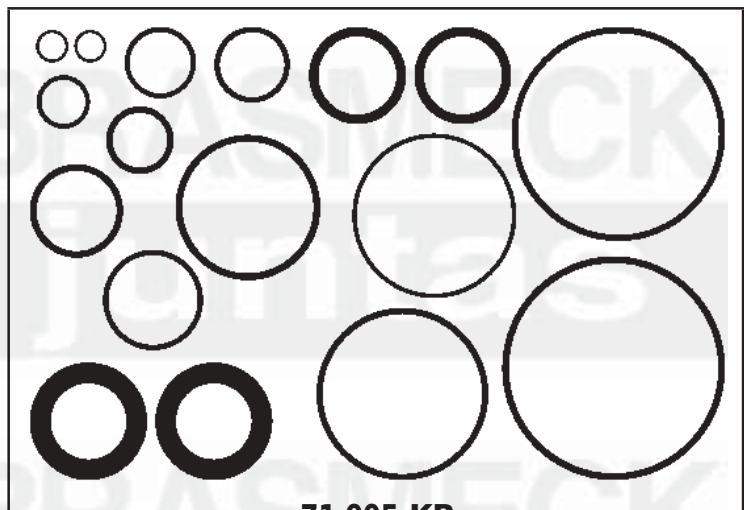

71.005-KB



71.073-CHA



71.075-NA



71.077-NA



71.078-PS



71.079-NA



71.080-NA



71.081-CB



71.082-NA



71.086-BO



71.091-NA



71.097-NA



71.095-S



71.098-S



71.099-S

DESENHOS FORA DE ESCALA

M.W.M D-225



71.601-OIL



71.221-BBS



71.222-BBS



71.226-CB



71.229-NA



71.232-NA



71.659-BBS



9,5 x 20,0 x 2,0



10,0 x 16,0 x 1,0

DESENHOS FORA DE ESCALA

CÓDIGO BRASMECK	CÓDIGO ORIGINAL	DESCRIÇÃO	QTDE.
71.611-C		Jogo de Juntas para Retificação de Válvulas c/ Cabeçote P/ 1cil Modelos: Trator Valmet 65 ID / 62 ID	
71.611-S		Jogo de Juntas para Retificação de Válvulas s/ Cabeçote P/ 1 cil Modelos: Trator Valmet 65 ID / 62 ID	
71.601-OIL	9.225.0.854.002.4	Junta do Cabeçote	1
71.221-BBS	6.207.0.853.007.4	Junta do Coletor de Escape.	1
71.222-BBS	6.321.3.853.009.4	Junta do Coletor de Admissão	1
71.226-CB	9.208.0.853.001.4	Junta da Tampa de Válvulas	1
71.229-NA	6.206.0.853.001.4	Junta do Suporte da BBA D'Água	1
71.232-NA	9.222.0.853.013.4	Junta da BBA D'Água	1
71.659-BBS	9.225.0.851.001.4	Junta da Curva do Escape.	1
		Arruela 9,5 x 20,0 x 2,0 Cobre	1
		Arruela 10,0 x 16,0 x 1,0 Alumínio	1

TODAS AS PEÇAS SÃO FORNECIDAS INDIVIDUALMENTE

M.W.M D-226

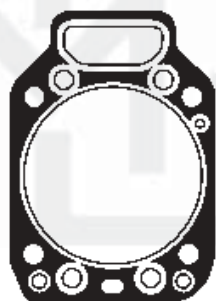

71.201-OIL



71.221-BBS



71.222-BBS



71.226-CB



71.229-NA



71.232-NA



71.659-BBS



9,5 x 20,0 x 2,0



10,0 x 16,0 x 1,0

DESENHOS FORA DE ESCALA

CÓDIGO BRASMECK	CÓDIGO ORIGINAL	DESCRIÇÃO	QTDE.
71.211-C		Jogo de Juntas para Retificação de Válvulas c/ Cabeçote P/ 1cil Modelos: Ford F-4000 / Valmet 86 ID	
71.211-S		Jogo de Juntas para Retificação de Válvulas s/ Cabeçote P/ 1 cil Modelos: Ford F-4000 / Valmet 86 ID	
71.201-OIL	6.226.0.854.008.4	Junta do Cabeçote	1
71.221-BBS	6.207.0.853.007.4	Junta do Coletor de Escape.	1
71.222-BBS	6.321.3.853.009.4	Junta do Coletor de Admissão	1
71.226-CB	9.208.0.853.001.4	Junta da Tampa de Válvulas	1
71.229-NA	6.206.0.853.001.4	Junta do Suporte da BBA D'Água	1
71.232-NA	9.222.0.853.013.4	Junta da BBA D'Água	1
71.659-BBS	9.225.0.851.001.4	Junta da Curva do Escape.	1
		Arruela 9,5 x 20,0 x 2,0 Cobre	1
		Arruela 10,0 x 16,0 x 1,0 Alumínio	1

TODAS AS PEÇAS SÃO FORNECIDAS INDIVIDUALMENTE

M.W.M D-229



71.101-OIL



71.126-CB



71.221-BBS



71.221-CHACH



71.222-BBS



71.229-NA



71.232-NA



71.621-CHA



9,5 x 20,0 x 2,0



10,0 x 16,0 x 1,0



112,0 x 4,0

DESENHOS FORA DE ESCALA

CÓDIGO BRASMECK	CÓDIGO ORIGINAL	DESCRIÇÃO	QTDE.
71.111-C		Jogo de Juntas para Retificação de Válvulas c/ Cabeçote P/ 1cil Modelos: Valmet E3000 / Agrale 4500 / Trator Agrícola 83 / Caminhão TX600 Dynapac	
71.111-S		Jogo de Juntas para Retificação de Válvulas s/ Cabeçote P/ 1 cil Modelos: Valmet E3000 / Agrale 4500 / Trator Agrícola 83 / Caminhão TX600 Dynapac	
71.101-OIL	6.227.0.854.001.4	Junta do Cabeçote	1
71.126-CB	9.229.0.853.006.4	Junta da Tampa de Válvula	1
71.221-BBS	6.207.0.853.007.4	Junta do Coletor de Escape.	1
71.221-CHACH	6.207.0.853.007.4	Junta do Escape. (turbo)	1
71.222-BBS	6.321.3.853.009.4	Junta do Coletor de Admissão	1
71.229-NA	6.206.0.853.001.4	Junta do Suporte da BBA D'Água	1
71.232-NA	9.222.0.853.013.4	Junta da BBA D'Água	1
71.621-CHA	6.232.0.852.003.4	Junta do Escape.	1
		Arruela 9,5 x 20,0 x 2,0 Cobre	1
		Arruela 10,0 x 16,0 x 1,0 Alumínio	1
		Anel de Borracha 112,0 x 4,0	1

TODAS AS PEÇAS SÃO FORNECIDAS INDIVIDUALMENTE

MOTOR 410-4 / 610-6 SÉRIE X-10 – VANS VOLARE**71.102-OIL****71.143-BBS****71.326-BO****71.437-NA****71.441-NA****71.443-NA****71.446-NA****71.642-BBS****71.642-CHA**

DESENHOS FORA DE ESCALA

CÓDIGO BRASMECK	CÓDIGO ORIGINAL	DESCRIÇÃO	QTDE.
71.711-C		Jogo de Juntas para Retificação de Válvula c/ Cabeçote p/ 1 cil Modelos: Caminhões VW 71.110 / 8.120 / 8.150 / 13.150 / 13.180 / 15.180 / 17.210 / 23.210 / 16.210 / 17.210 / 17.240 Agrale 7.000 / 7.500 / 8.500	
71.711-S		Jogo de Juntas para Retificação de Válvula s/ Cabeçote p/ 1 cil Modelos: Caminhões VW 71.110 / 8.120 / 8.150 / 13.150 / 13.180 / 15.180 / 17.210 / 23.210 / 16.210 / 17.210 / 17.240 Agrale 7.000 / 7.500 / 8.500	
71.102-OIL	9.610.0.854.014.4	Junta do Cabeçote	1
71.143-BBS	9.410.0.853.002.4	Junta Curva da Admissão	1
71.326-BO	9.610.0.853.003.4	Junta da Tampa de Válvula	1
71.437-NA	9.410.0.853.003.4	Junta Curva do Escape.	1
71.441-NA	9.610.0.853.017.4	Junta do Bocal da BBA D'Água	1
71.443-NA	9.610.0.853.009.4	Junta do Termostato	1
71.446-NA	9.410.0.853.010.4	Junta do Respiro do Motor	1
71.642-BBS	9.610.0.853.014.4	Junta do Coletor de Escape.	1
71.642-CHA	9.610.0.853.014.4	Junta do Coletor de Escape.	1

TODAS AS PEÇAS SÃO FORNECIDAS INDIVIDUALMENTE

SPRINT 4 CILS



71.002-OIL



71.071-CB



71.073-CHA



71.074-NA



71.076-BO



71.082-NA

DESENHOS FORA DE ESCALA

CÓDIGO BRASMECK	CÓDIGO ORIGINAL	DESCRIÇÃO	QTDE.
71.012-C		Jogo de Juntas para Retificação de Válvula c/ Cabeçote p/ 1 cil Modelos: Xterra / Frontier Cabine Dupla / Blazer / S-10 / Agrale: 6.000 / Volere / VW Van LT 2 (Alemã) - Agrale Van Furgovan / Troller	
71.012-S		Jogo de Juntas para Retificação de Válvula s/ Cabeçote p/ 1 cil Modelos: Xterra / Frontier Cabine Dupla / Blazer / S-10 / Agrale: 6.000 / Volere / VW Van LT 2 (Alemã) - Agrale Van Furgovan / Troller	
71.002-OIL	9.407.0.854.807.4	Junta do Cabeçote	1
71.071-CB	9.407.0.853.008.4	Junta do Coletor de Admissão	1
71.073-CHA	9.607.0.853.008.4	Junta do Coletor Escape.	4
71.074-NA	9.407.0.853.005.4	Junta Curva de Admissão	1
71.076-BO	9.407.0.853.003.4	Junta da Tampa de Válvula	1
71.082-NA	9.607.0.853.005.4	Junta Duto Coletor de Admissão	1

TODAS AS PEÇAS SÃO FORNECIDAS INDIVIDUALMENTE

SPRINT 6 CILS



71.003-OIL



71.073-CHA



71.074-NA



71.081-CB



71.082-NA



71.086-BO

DESENHOS FORA DE ESCALA

CÓDIGO BRASMECK	CÓDIGO ORIGINAL	DESCRIÇÃO	QTDE.
71.014-C		Jogo de Juntas para Retificação de Válvula c/ Cabeçote Modelos: Pick-Up F-250 – GMC 3.500-HD / 6.150	
71.014-S		Jogo de Juntas para Retificação de Válvula s/ Cabeçote Modelos: Pick-Up F-250 – GMC 3.500-HD / 6.150	
71.003-OIL	9.407.0.854.807.4	Junta do Cabeçote	1
71.073-CHA	9.607.0.853.008.4	Junta do Coletor Escape.	6
71.074-NA	9.407.0.853.005.4	Junta Curva de Admissão	1
71.076-BO	9.407.0.853.003.4	Junta da Tampa de Válvula	1
71.081-CB	9.607.0.853.006.4	Junta do Coletor de Admissão	1
71.082-NA	9.607.0.853.005.4	Junta Duto Coletor de Admissão	1
71.086-BO	9.607.0.853.001.4	Junta da Tampa de Válvula	1

TODAS AS PEÇAS SÃO FORNECIDAS INDIVIDUALMENTE

Clark 450 5M – A-60 / F-1000 (85/91)



10.500-CB



11.147-GV



50.183-GV

DESENHOS FORA DE ESCALA

CÓDIGO BRASMECK	CÓDIGO ORIGINAL	DESCRIÇÃO	QTDE.
10.081-GV		Jogo de Juntas do Câmbio	
10.500-CB	7.362.587	Junta da Tampa da Tomada de Força	2
11.147-GV		Junta da Tampa do Câmbio	1
50.183-GV	503.441	Junta da Moringa	1

TODAS AS PEÇAS SÃO FORNECIDAS INDIVIDUALMENTE

Câmbio Clark Caixa 280 V / VH / VHC / VHD 5M – A60 / C60 / D60 Caminhão VW D950 / P400 / DTI 400TD / 6.80 / 6.90 / 11.130 / 13.130



10.376-GV



10.500-CB



50.183-GV

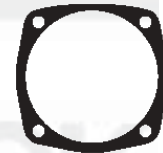

50.185-GV



50.187-GV



50.188-GV

DESENHOS FORA DE ESCALA

CÓDIGO BRASMECK	CÓDIGO ORIGINAL	DESCRIÇÃO	QTDE.
10.193-GV		Jogo de Juntas do Cambio	
10.376-GV	7.326.405	Junta do Câmbio	1
10.500-CB	7.362.587	Junta da Tampa da Tomada de Força	2
50.183-GV	503.441	Junta da Moringa	1
50.185-GV	504.253	Junta da Tampa de Inspeção	1
50.187-GV	0.299.575.9	Junta da Tampa Superior	1
50.188-GV	T13.311.971	Junta da Alavanca	1

TODAS AS PEÇAS SÃO FORNECIDAS INDIVIDUALMENTE

DESENHOS FORA DE ESCALA

Câmbio Clark CL-450 / FS 4205 / 4205-A 5M – Caminhão VW 11.130/13.130



10.376-GV



10.500-CB



11.147-GV



50.183-GV



50.185-GV



50.188-GV



50.189-GV

CÓDIGO BRASMECK	CÓDIGO ORIGINAL	DESCRIÇÃO	QTDE.
11.140-GV		Jogo de Juntas do Cambio	
10.376-GV	7.326.405	Junta do Câmbio	1
10.500-CB	7.362.587	Junta da Tampa da Tomada de Força	2
11.147-GV		Junta da Tampa do Câmbio	1
50.183-GV	503.441	Junta da Moringa	1
50.185-GV	504.253	Junta da Tampa de Inspeção	1
50.188-GV	T13.311.971	Junta da Alavanca	1
50.189-GV		Junta do Câmbio	1

TODAS AS PEÇAS SÃO FORNECIDAS INDIVIDUALMENTE

DESENHOS FORA DE ESCALA

Câmbio Clark Caixa 280 V / VH / VHC / VHD 5M – A60 / C60 / D60 Caminhão VW D950 / P400 / DTI 400TD / 6.80 / 6.90 / 11.130 / 13.130



10.500-CB



50.187-GV



50.183-GV



50.185-GV



50.189-GV

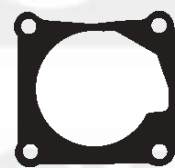

50.186-NA

CÓDIGO BRASMECK	CÓDIGO ORIGINAL	DESCRIÇÃO	QTDE.
60.692-GV		Jogo de Juntas do Câmbio	
10.500-CB	7.362.587	Junta da Tampa da Tomada de Força	2
50.183-GV	503.441	Junta da Moringa	1
50.185-GV	504.253	Junta da Tampa de Inspeção	1
50.186-NA		Junta da Tampa	1
50.187-GV	0.299.575.9	Junta da Tampa Superior	1
50.189-GV		Junta do Câmbio	1

TODAS AS PEÇAS SÃO FORNECIDAS INDIVIDUALMENTE

DESENHOS FORA DE ESCALA

Câmbio Caixa Eaton 5106 / 5306 / 6005 / 6305 / 6206 / 6306 - 6M



CÓDIGO BRASMECK	CÓDIGO ORIGINAL	DESCRIÇÃO	QTDE.
61.790-GV		Jogo de Juntas do Cambio	
10.500-CB	7.362.587	Junta da Tampa da Tomada de Força	2
50.189-GV		Junta do Câmbio	1
61.791-GV		Junta do Câmbio	1
61.792-GV		Junta do Câmbio	1
61.793-GV		Junta do Câmbio	1
61.794-GV		Junta do Câmbio	1

TODAS AS PEÇAS SÃO FORNECIDAS INDIVIDUALMENTE

DESENHOS FORA DE ESCALA

Câmbio F-1000 - 4M



CÓDIGO BRASMECK	CÓDIGO ORIGINAL	DESCRIÇÃO	QTDE.
71.180-GV		Jogo de Juntas do Cambio	
10.505-GV	7.362.604	Junta do Retentor da Engrenagem Principal	4
10.510-GV		Junta da Caixa de Controle	1
10.511-GV	8L.7686 ^A	Capa Retentor Engrenagem Principal	1
10.548-GV		Junta da Tampa Lateral	1
10.549-GV		Junta do Controle de Mudança de Velocidade	1
11.781-GV		Junta da Tampa de Inspeção Externa	1

TODAS AS PEÇAS SÃO FORNECIDAS INDIVIDUALMENTE

DESENHOS FORA DE ESCALA

Câmbio F-4000 – 4M



10.197-GV



10.431-GV



10.500-CB



10.504-CB



10.505-GV



11.296-GV

CÓDIGO BRASMECK	CÓDIGO ORIGINAL	DESCRIÇÃO	QTDE.
71.280-GV		Jogo de Juntas do Cambio	
10.197-GV		Junta Régua da Trava	1
10.431-GV	8MTH.7223-A	Junta da Tampa do Câmbio	1
10.500-CB	7.362.587	Junta da Tampa da Tomada de Força	1
10.504-CB	7.362.603	Junta da Caixa de Transferência	1
10.505-GV	7.362.604	Junta do Retentor da Engrenagem Principal	4
11.296-GV		Junta do Câmbio	1

TODAS AS PEÇAS SÃO FORNECIDAS INDIVIDUALMENTE

DESENHOS FORA DE ESCALA

Câmbio 240V – F-1000 5M



10.431-GV



10.500-CB



10.505-GV



11.286-GV



71.292-GV



71.293-GV

CÓDIGO BRASMECK	CÓDIGO ORIGINAL	DESCRIÇÃO	QTDE.
71.300-GV		Jogo de Juntas do Cambio	
10.431-GV		Junta da Tampa do Câmbio	1
10.500-CB	7.362.587	Junta da Tampa da Tomada de Força	1
10.505-GV	7.362.604	Junta do Retentor da Engrenagem Principal	4
11.286-GV		Junta do Câmbio	1
11.292-GV		Junta do Câmbio	1
71.293-GV		Junta do Câmbio	1

TODAS AS PEÇAS SÃO FORNECIDAS INDIVIDUALMENTE

Câmbio 240V – F-4000 4/5M



10.197-GV



10.376-GV



10.431-GV



10.500-CB



10.504-CB



10.505-GV



11.286-GV



11.296-GV



71.293-GV



71.294-NA



71.295-GV

DESENHOS FORA DE ESCALA

CÓDIGO BRASMECK	CÓDIGO ORIGINAL	DESCRIÇÃO	QTDE.
71.290-GV		Jogo de Juntas do Cambio	
10.197-GV		Junta Régua da Trava	1
10.376-GV			
10.431-GV	8MTH.7223-A	Junta da Tampa do Câmbio	1
10.500-CB	7.362.587	Junta da Tampa da Tomada de Força	1
10.504-CB	7.362.603	Junta da Caixa de Transferência	1
10.505-GV	7.362.604	Junta do Retentor da Engrenagem Principal	4
11.286-GV		Junta do Câmbio	1
11.296-GV		Junta do Câmbio	1
71.293-GV		Junta do Câmbio	1
71.294-NA		Junta do Câmbio	1
71.295-GV		Junta do Câmbio	1

TODAS AS PEÇAS SÃO FORNECIDAS INDIVIDUALMENTE

DESENHOS FORA DE ESCALA

Turbina Caminhão VW / M.W.M 229



48.379-CH



59.266-NA



59.376-NA



71.422-CHACH



14,0x20,0x1,5-AL



26,0x36,0x1,0-AL

CÓDIGO BRASMECK	CÓDIGO ORIGINAL	DESCRIÇÃO	QTDE.
71.125-DVM		Jogo de Juntas da Turbina Caminhão VW / M.W.M 229	
48.379-CH		Junta da Base da Turbina	1
59.266-NA	1.671.153	Junta da Lubrificação	1
59.376-NA	1.671.152	Junta do Cano de Retorno	1
71.422-CHACH		Junta do Caracol	1
		Arruela de Alumínio 14,0x20,0x1,5-AL	4
		Arruela de Alumínio 26,0x36,0x1,0-AL	2

TODAS AS PEÇAS SÃO FORNECIDAS INDIVIDUALMENTE

DESENHOS FORA DE ESCALA

Turbina TK -107 S2A / F1000 / M.W.M



48.373-NA



59.266-NA



59.376-NA



71.221-CHACH



71.373-CH



71.375-NA



14,0x20,0x1,5-AL

CÓDIGO BRASMECK	CÓDIGO ORIGINAL	DESCRIÇÃO	QTDE.
71.195-DVM		Jogo de Juntas da Turbina TK -107 S2A / F1000 / M.W.M	
48.373-CH	TAF.145.453	Junta da Base da Turbina	1
59.266-NA	1.671.153	Junta da Lubrificação	1
59.376-NA	1.671.152	Junta do Cano de Retorno	1
71.221-CHACH	6.207.0.853.007.4	Junta do Coletor de Escape.	4
71.373-CH		Junta da Turbina	1
71.375-NA		Junta da Turbina	1
		Arruela de Alumínio	4
		Arruela de Alumínio 14,0x20,0x1,5	2

TODAS AS PEÇAS SÃO FORNECIDAS INDIVIDUALMENTE

DESENHOS FORA DE ESCALA

Turbina D-225 6 cils (veicular / agrícola)



CÓDIGO BRASMECK	CÓDIGO ORIGINAL	DESCRIÇÃO	QTDE.
71.196-DVM		Jogo de Juntas da Turbina D-225 6 cils (veicular / agrícola)	
48.372-CH	352.098.0080	Junta do Caracol da Turbina	1
48.373-CH	TAF-145.453	Junta da Base da Turbina	1
59.266-NA	1.671.153	Junta da Lubrificação	1
59.376-NA	1.671.152	Junta do Cano de Retorno	1
71.221-CHACH	6.207.0.853.007.4	Junta do Coletor de Escape.	6
71.375-NA		Junta da Turbina	1

TODAS AS PEÇAS SÃO FORNECIDAS INDIVIDUALMENTE

DESENHOS FORA DE ESCALA

Turbina M.W.M. X-10 4 cils



CÓDIGO BRASMECK	CÓDIGO ORIGINAL	DESCRIÇÃO	QTDE.
71.225-DVM		Jogo de Juntas da Turbina M.W.M. X-10 4 cils	
48.379-CH		Junta da Base da Turbina	1
71.374-CHA		Junta do Caracol da Turbina	1
71.429-BBS		Junta do Coletor	1
71.939-NA		Junta do Cano de Retorno	1
71.940-NA		Junta do Cano de Óleo	1

TODAS AS PEÇAS SÃO FORNECIDAS INDIVIDUALMENTE

DESENHOS FORA DE ESCALA

Turbina M.W.M. X-10 6 cils



48.379-CH



71.422-CHACH



71.429-BBS



71.939-NA



71.940-NA

CÓDIGO BRASMECK	CÓDIGO ORIGINAL	DESCRIÇÃO	QTDE.
71.325-DVM		Jogo de Juntas da Turbina M.W.M. X-10 6 cils	
48.379-CH		Junta da Base da Turbina	1
71.374-CHA		Junta do Caracol da Turbina	1
71.429-BBS		Junta do Coletor	1
71.939-NA		Junta do Cano de Retorno	1
71.940-NA		Junta do Cano de Óleo	1

TODAS AS PEÇAS SÃO FORNECIDAS INDIVIDUALMENTE

DESENHOS FORA DE ESCALA

Turbina TK 107/F1000/F2000/F4000 - Caminhões VW 4 cils



48.372-CH



48.373-CH



48.375-NA



59.266-NA



59.376-NA



71.221-CHACH



71.375-NA



14,0x20,0x1,5-AL



CÓDIGO BRASMECK	CÓDIGO ORIGINAL	DESCRIÇÃO	QTDE.
71.896-DVM		Jg. de Juntas Turbina TK 107/F1000/F2000/F4000 - Caminhões VW 4 cils	
48.372-CH	352.098.0880	Junta do Caracol da Turbina	1
48.373-CH		Junta da Turbina	1
48.375-NA	TAF.145.453	Junta da Base da Turbina	1
59.266-NA	1.671.153	Junta da Lubrificação	1
59.376-NA	1.671.152	Junta do Cano de Retorno	1
71.221-CHACH	6.207.0.853.007.4	Junta do Coletor do Escapamento	4
71.375-NA		Junta da Turbina	1
		Arruela de Alumínio 14,0x20,0x1,5	4
		Arruela de Alumínio	4

TODAS AS PEÇAS SÃO FORNECIDAS INDIVIDUALMENTE

DESENHOS FORA DE ESCALA



71.126-BO



71.126-NA



71.155-CB



71.165-NA

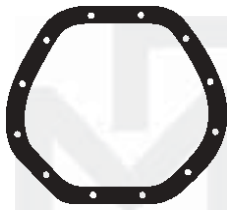

71.166-NA

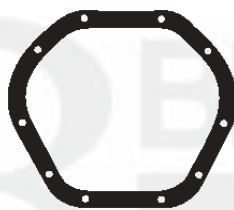

71.177-NA

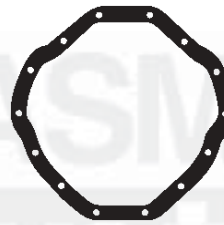

71.277-NA



71.278-NA



71.279-NA



71.926-CB



95.062-NA

CÓDIGO BRASMECK	CÓDIGO ORIGINAL	DESCRIÇÃO	QTDE.
71.126-BO	9.229.0.853.006.4	Junta da Tampa de Válvulas	
71.126-NA	9.229.0.853.006.4	Junta da Tampa de Válvulas	
71.155-CB	T16.407.991	Junta da Calota Dianteira Caminhão Volkswagen	
71.165-NA		Junta do Diferencial F-1000 / F-2000 5 Marchas	
71.166-NA		Junta do Diferencial F-1000 / Turbo / Silverado (12 furos)	
71.177-NA		Junta do Diferencial F-2000 / F-4000 80/...	
71.277-NA		Junta do Diferencial F-4000 até 1982	
71.278-NA		Junta do Compressor Bendix	
71.279-NA	9.720.5.246	Junta do Compressor Ford / VW / Chevrolet (Caminhões)	
71.926-CB	8.366.4.636.2	Junta da Tampa de Válvulas Valmet 4 cils	
95.062-NA		Junta do Diferencial F-1000 / F-100 82/... Albarus	

TODAS AS PEÇAS SÃO FORNECIDAS INDIVIDUALMENTE



TECNOLOGIA ORIGINAL EM PEÇAS DE REPOSIÇÃO



PERKINS



MAXION HS 2.5

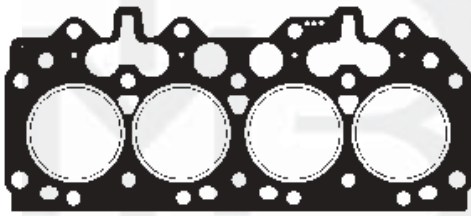

70.101-OIL



70.071-NA



70.072-NA



70.073-NA



70.074-BO



70.075-CH



70.076-NA



70.077-NA



70.078-NA



70.079-NA



70.080-NA



70.081-NA



70.082-NA



70.083-NA



70.084-NA



70.085-NA



70.086-NA



70.087-NA



70.127-BO

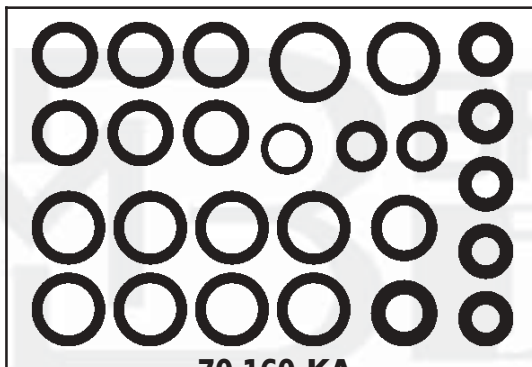

70.160-KA

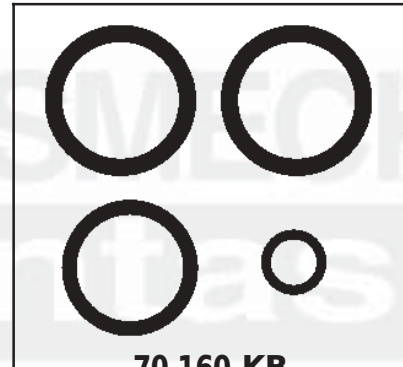

70.160-KB

DESENHOS FORA DE ESCALA

PERKINS 3152 / 50X

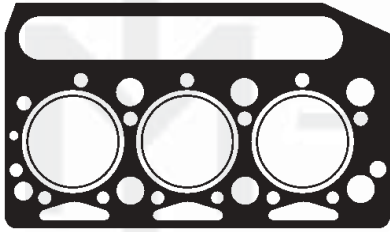

70.001-OIL

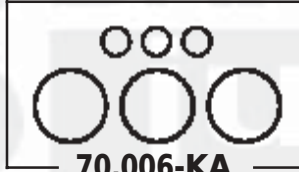

70.006-KA

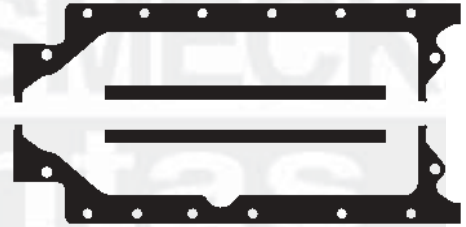

70.015-NA



70.021-BBS



70.026-CB

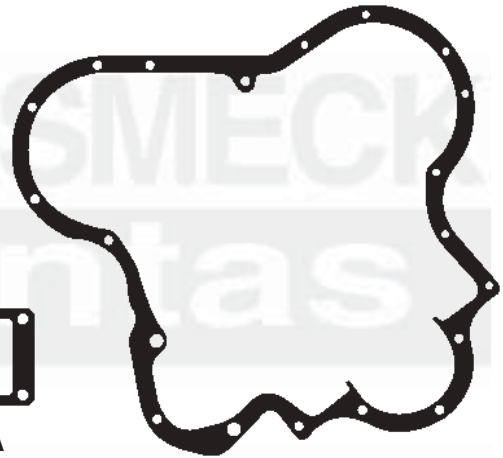

70.027-NA



70.028-NA



70.029-NA



70.031-NA



70.030-NA



70.032-NA



70.033-NA



70.034-NA



70.035-NA



70.036-NA



70.037-NA



70.038-NA



70.039-NA



70.040-NA



70.041-NA



70.042-NA



70.046-NA



70.019-NA



70.065-BO



70.446-BBS



9.0013-BR



9.0572-BR

DESENHOS FORA DE ESCALA

PERKINS 3152 Injeção Direta (Moderno)

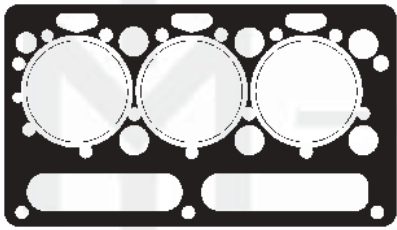

70.002-OIL



70.015-NA



70.022-BBS



70.025-CB



70.027-NA



70.028-NA



70.030-NA



70.031-NA



70.032-NA



70.034-NA



70.035-NA



70.037-NA



70.039-NA



70.040-NA



70.041-NA



70.042-NA



70.044-NA



70.046-NA



70.047-NA

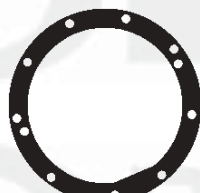

70.049-NA



70.051-DVM



70.252-NA



70.342-NA



70.379-BO



70.446-BBS



70.867-CU



9.0013-BR



9.0572-BR

DESENHOS FORA DE ESCALA

PERKINS 1006 / 1006 T ASPIRADO / TURBINADO



70.203-OIL



48.373-CH



70.116-NA

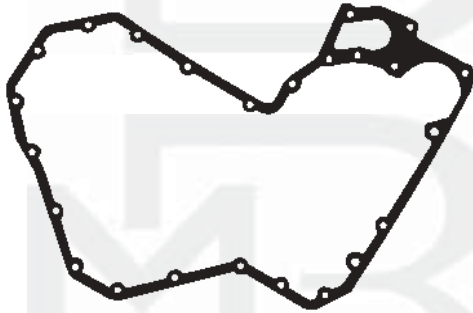

70.130-NA

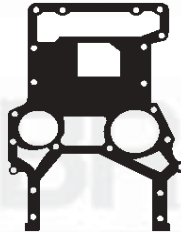

70.131-NA



70.132-NA



70.133-NA



70.134-NA



70.135-NA



70.137-NA



70.138-NA



70.139-NA



70.140-NA



70.141-NA



70.142-NA



70.143-NA



70.144-NA



70.153-NA



70.164-NA



70.166-NA



70.167-NA



70.168-NA



70.169-NA



70.170-NA



70.172-NA



70.173-NA



70.174-NA



70.175-NA



70.176-NA



70.178-NA



70.219-CHA



70.221-CHA



70.222-CHA



70.223-CHA



70.227-BO



71.204-KA

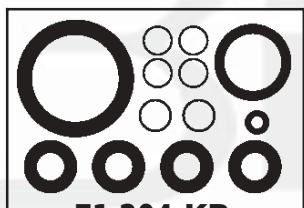

71.204-KB



70.239-NA



70.342-NA



70.372-NA



71.373-CH

DESENHOS FORA DE ESCALA

Maxion 4.000 / 4.000T Agrícola



70.302-OIL



48.373-CH



48.441-NA



59.266-NA



59.376-NA



70.035-NA

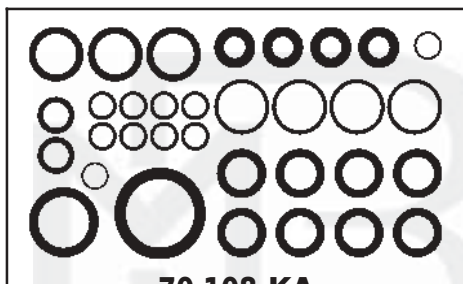

70.108-KA

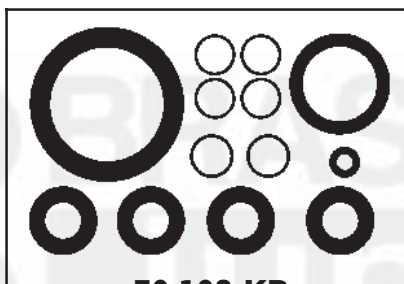

70.108-KB



70.126-BO

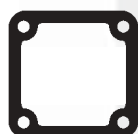

70.128-NA



70.129-NA



70.149-NA



70.154-NA

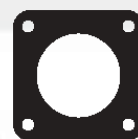

70.155-NA



70.239-NA



70.316-NA

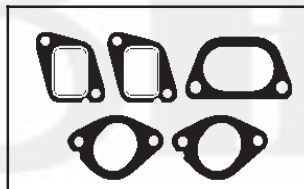

70.320-BBS



70.329-NA



70.334-NA



70.335-NA



70.343-NA



70.346-NA



70.357-NA



70.361-NA



70.366-NA



70.368-BBS



70.369-NA



70.372-NA



70.373-NA



70.374-NA



70.392-CH



70.393-NA



70.859-CU



71.373-CH



9.1050-BRGS



9.1972-BRGS



9.3045-BREF

DESENHOS FORA DE ESCALA

S4/S4T (D20/D40/GMC 6.150/6.100 Plus) Aspirado/Turbinado



70.302-OIL



48.373-CH



48.441-NA



59.266-NA



59.376-NA



70.035-NA

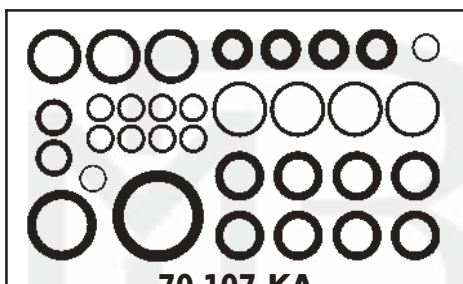

70.107-KA

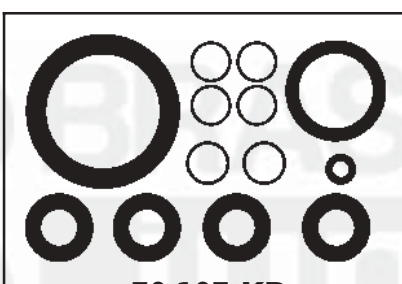

70.107-KB



70.126-BO



70.149-NA



70.155-NA



70.154-NA

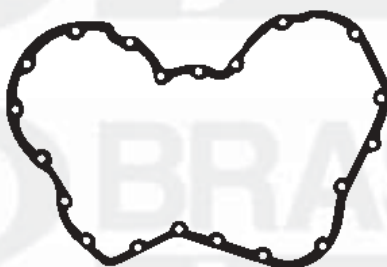

70.156-NA



70.128-NA



70.129-NA



70.239-NA



70.315-CB



70.320-BBS



70.334-NA



70.335-NA



70.343-NA



70.346-NA



70.357-NA



70.361-NA



70.366-NA



70.368-BBS



70.369-NA



70.372-NA



70.373-NA



70.374-NA



70.392-CH



70.393-NA



70.859-CU



71.373-CH



9.1050-BRGS



9.1972-BRGS

DESENHOS FORA DE ESCALA

PERKINS 4203 / 8BR Injeção Indireta

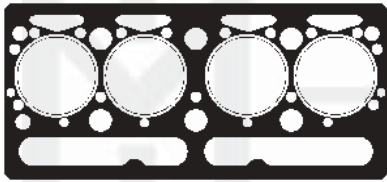

70.401-OIL



70.019-NA



70.021-BBS



70.031-NA



70.033-NA



70.035-NA



70.045-CU

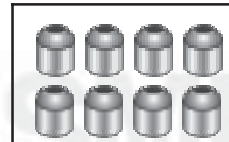

70.065-BO



70.361-NA



70.362-PS

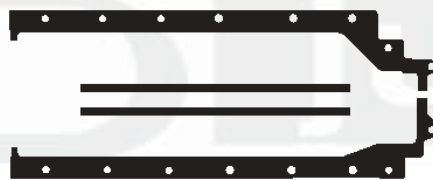

70.415-NA



70.426-CB



70.428-NA



70.429-NA



70.430-NA



70.431-NA



70.432-CB



70.433-CB



70.434-CB



70.435-PS



70.436-NA



70.437-NA



70.439-NA



70.441-NA



70.442-NA



70.443-NA



70.446-BBS



70.448-NA



70.449-NA



70.451-NA



70.457-NA



70.458-GV



70.459-CB



70.461-BO



70.559-CHA



70.822-CU



70.844-NA



9.0013-BRG



9.0572-BR

DESENHOS FORA DE ESCALA

PERKINS 4203 / MF 65 Injeção Indireta

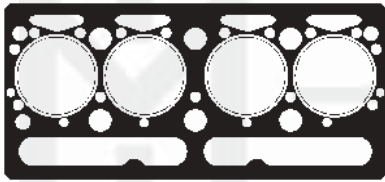

70.401-OIL



70.019-NA



70.021-BBS



70.031-NA



70.033-NA



70.035-NA



70.037-NA



70.045-CU

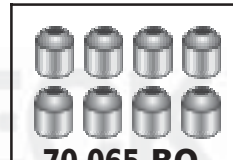

70.065-BO



70.361-NA



70.426-CB



70.428-NA



70.431-NA



70.432-CB



70.433-CB

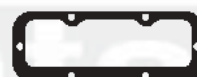

70.434-CB



70.435-PS



70.436-NA



70.439-NA



70.441-NA



70.443-NA



70.446-BBS



70.448-NA



70.449-NA



70.451-NA

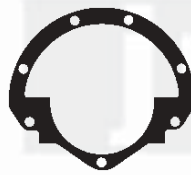

70.457-NA

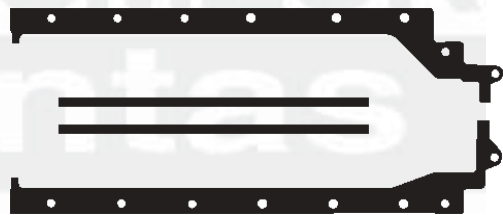

70.515-NA

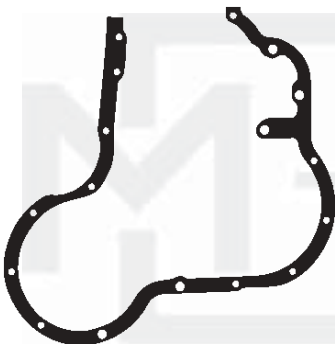

70.529-NA



70.458-GV



70.557-NA



70.559-BBS



70.822-CU



70.844-NA



9.0013-BR



9.0572-BR

PERKINS 4203 / 65X - Injeção Direta

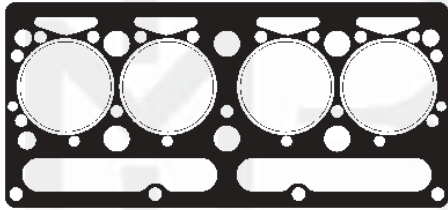

70.601-OIL



70.019-NA



70.031-NA



70.035-NA



70.037-NA

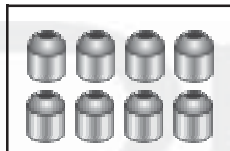

70.065-BO



70.067-BO



70.432-CB



70.436-NA



70.439-NA



70.441-NA



70.443-NA



70.446-BBS



70.449-NA



70.451-NA



70.457-NA



70.461-BO



70.515-NA



70.529-NA



70.557-NA



70.621-BBS



70.622-BBS



70.626-CB



70.628-NA



70.631-NA



70.658-NA



70.823-CU



70.844-NA



9.0013-BRG



9.0572-BR

PERKINS 4236 Turbo / MF 292

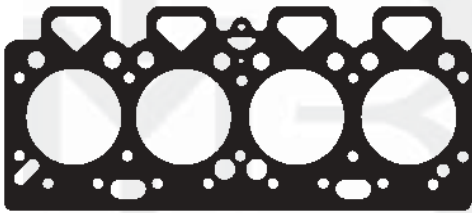

70.302-OIL



48.372-CH



48.375-NA



48.379-CH



70.035-NA



59.266-NA

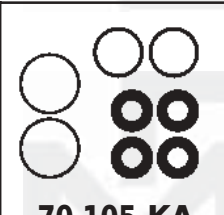

70.105-KA



70.234-NA

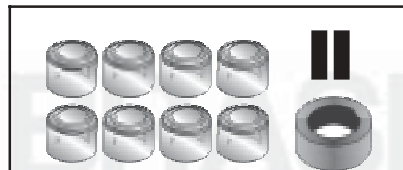

70.310-KB



70.316-NA

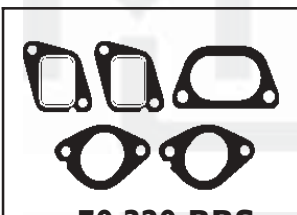

70.320-BBS



70.328-NA



70.329-NA



70.331-CB



70.326-CB



70.332-NA



70.333-NA



70.334-NA



70.335-NA



70.336-NA



70.339-NA



70.342-NA



70.343-NA

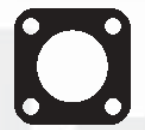

70.344-NA



70.345-NA



70.346-NA



70.348-NA



70.349-GV



70.352-NA



70.357-NA



70.358-NA



70.359-NA



70.360-CB



70.361-NA



70.362-PS



70.363-CB



70.364-NA



70.366-NA



70.369-NA



70.370-PS



70.372-NA



70.373-NA



70.374-NA



70.378-CHA



70.399-NA



70.859-CU



71.373-CH

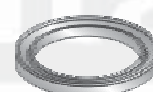

9.1050-BRGS



9.1972-BRGS

PERKINS 4236 Turbo / MF 292

CÓDIGO BRASMECK	CÓDIGO ORIGINAL	DESCRIÇÃO	QTDE.
70.105-CC		Jogo de Juntas Motor Com Cabeçote Com Retentor	
70.105-CS		Jogo de Juntas Motor Com Cabeçote Sem Retentor	
70.105-SS		Jogo de Juntas Motor Sem Cabeçote Sem Retentor	
70.302-OIL	36.812.338	Junta do Cabeçote	1
48.372-CH	352.098.0880	Junta do Caracol da Turbina	1
48.375-NA		Junta do Cano de Retorno	1
48.379-CH		Junta da Base da Turbina	1
59.266-NA	1.671.153	Junta Lubrificação da Turbina	1
70.035-NA	70.490.063	Junta da BBA Injetora	1
70.105-KA		Kit de Arruelas	1
70.234-NA	36.866.722	Junta	1
70.310-KB		Kit de Borrachas	1
70.316-NA	36.815.707	Junta do Carter	1
70.320-BBS	3668C/002/003/007	Jogo de Juntas do Coletor de Admissão/Escape	1
70.326-CB	70.490.149	Junta da Tampa de Válvulas	1
70.328-NA	36.814.127	Junta da Caixa de Distribuição	1
70.329-NA	36.813.137	Junta da Tampa da Caixa	1
70.331-CB	33.825.419	Junta da Tampa de Inspeção	1
70.332-NA	36.832.138	Junta do Bocal	1
70.333-NA	36.832.409	Junta da Conexão	1
70.334-NA	36.851.409	Junta da Tampa Traseira do Cabeçote	1
70.335-NA	36.853.514	Junta da Carcaça ao Cabeçote	1
70.336-NA	36.862.151	Junta da Conexão Superior da Saída D'Água	1
70.339-NA	36.862.517	Junta do Filtro Lubrificante ao Bloco e Placa	1
70.342-NA	36.851.113	Junta da BBA Alimentadora ao Bloco	1
70.343-NA	36.817.157	Junta da Carcaça ao Cabeçote	1
70.344-NA	36.862.152	Junta	1
70.345-NA	0.490.734	Junta da Carcaça Termostato	1
70.346-NA	36.866.721	Junta da BBA D'Água	1
70.348-NA		Junta Sucção de Óleo	1
70.349-GV	897.148	Junta da BBA Hidráulica	1
70.352-NA	36.866.428	Junta do Tubo Escape. de Óleo	1
70.357-NA	36.832.122	Junta do Tubo da BBA de Óleo	1
70.358-NA	36814127	Junta do Tubo Alívio	1
70.359-NA	36.862.523	Junta do Filtro Lubrificante ao Bloco e Placa	1
70.360-CB	36.835.425	Junta da Carcaça Conexão Superior	1
70.361-NA	36.865.511	Junta da Caixa ao Adaptador Exaustor	1
70.362-PS	36.866.416	Junta do Adaptador ao Exaustor	1
70.363-CB	36.825.107	Junta da Tampa de Inspeção	1
70.364-NA	36.866.724	Junta da BBA D'Água	1
70.366-NA	70.490.146	Junta da BBA D'Água	2
70.369-NA	0.490.773	Junta da BBA Injetora	1
70.370-PS		Junta do Compressor	1
70.372-NA	38.858.102	Junta da Base BBA Combustível	1
70.373-NA	70.490.145	Junta da BBA D'Água	1
70.374-NA	70.490.143	Junta da BBA Injetora	1
70.378-CHA	1.877.671	Junta do Escapamento	1
70.399-NA		Junta	1
70.859-CU	0.490.301	Gaxeta do Escapamento	1
71.373-CH		Junta da Turbina	1
9.1050-BRGS	2.415.391	Retentor da Distribuição	1
9.1972-BRGS	2.415.391	Retentor Traseiro	1

TODAS AS PEÇAS SÃO FORNECIDAS INDIVIDUALMENTE

PERKINS 4236 – D-10 / D-20 Veicular Injeção Direta

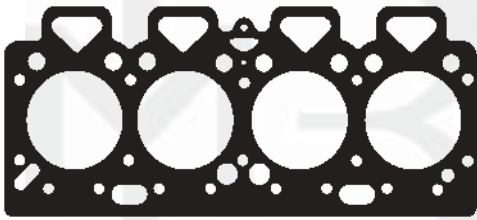

70.302-OIL



70.035-NA



70.310-KB



70.317-NA

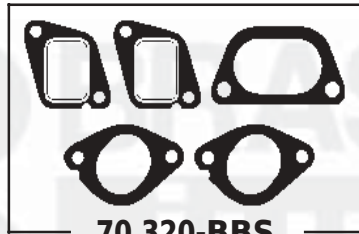

70.320-BBS



70.326-CB



70.328-NA

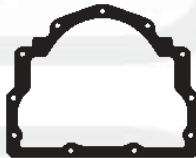

70.330-NA



70.334-NA



70.335-NA



70.336-NA



70.339-NA



70.341-NA



70.342-NA



70.343-NA



70.345-NA



70.356-NA



70.358-NA



70.359-NA



70.360-CB



70.361-NA



70.363-CB



70.364-NA



70.366-NA



70.368-BBS



70.373-NA



70.374-NA



70.859-CU



70.867-CU



9.1050-BRGS

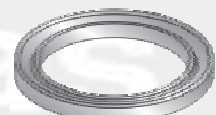

9.1972-BRGS

PERKINS 4236 – Agrícola – Massey Ferguson

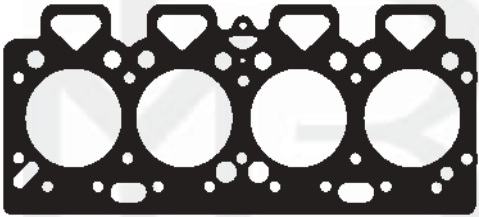

70.302-OIL



70.035-NA



70.310-BO



70.316-NA

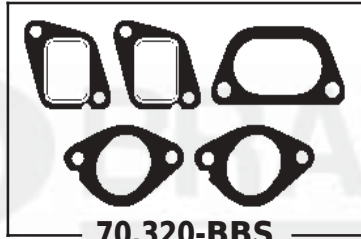

70.320-BBS



70.326-CB

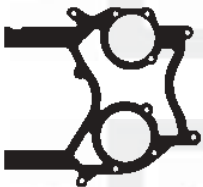

70.328-NA



70.329-NA

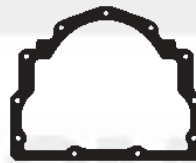

70.330-NA



70.334-NA



70.335-NA



70.336-NA



70.341-NA



70.342-NA



70.343-NA



70.345-NA



70.359-NA



70.360-CB



70.361-NA



70.362-PS



70.363-CB



70.364-NA



70.366-NA



70.368-BBS



70.859-CU



70.867-CU



9.1050-BRGS



9.1972-BRGS

DESENHOS FORA DE ESCALA

PERKINS 4236 Q-20B

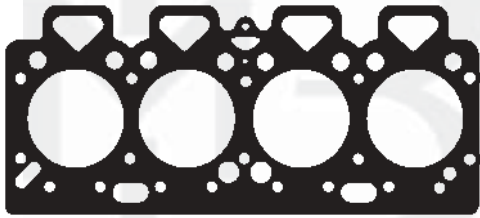

70.302-OIL



70.035-NA

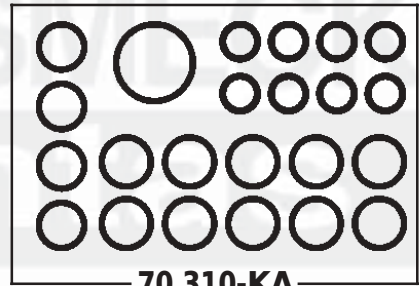

70.310-KA



70.310-KB



70.318-CB

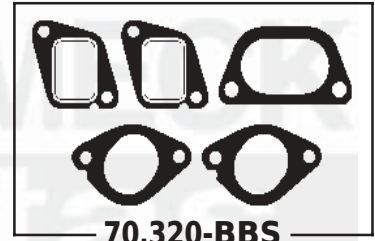

70.320-BBS



70.326-CB



70.328-NA



70.333-NA



70.334-NA



70.335-NA



70.336-NA



70.339-NA



70.343-NA



70.345-NA



70.346-NA



70.347-NA



70.356-NA



70.357-NA



70.358-NA



70.359-NA



70.360-CB



70.361-NA



70.363-CB



70.366-NA



70.368-BBS



70.369-NA



70.372-NA



70.373-NA



70.374-NA



70.859-CU



70.867-CU



70.869-BO



9.1050-BRGS



9.1972-BRGS

PERKINS 4248 – Agrícola

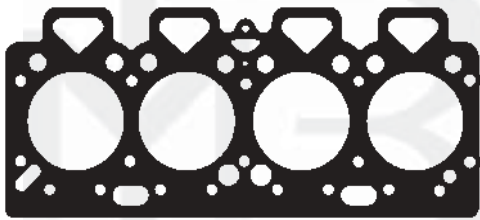

70.302-OIL



70.019-NA



70.035-NA



70.234-NA

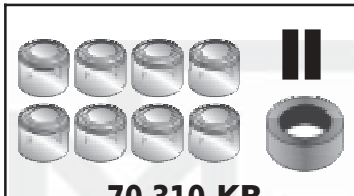

70.310-KB



70.316-NA

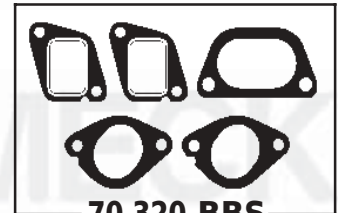

70.320-BBS



70.326-CB



70.328-NA

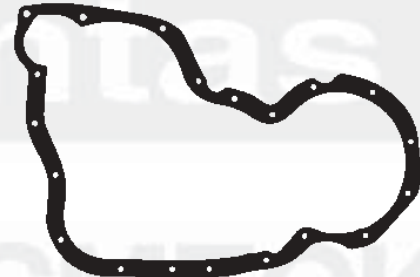

70.329-NA



70.330-NA



70.331-CB



70.332-NA



70.333-NA



70.334-NA



70.335-NA



70.336-NA



70.339-NA



70.342-NA



70.343-NA



70.344-NA



70.345-NA



70.346-NA



70.357-NA



70.358-NA



70.359-NA



70.360-CB



70.361-NA



70.362-PS



70.363-CB



70.364-NA



70.366-NA



70.369-NA



70.370-PS



70.372-NA



70.373-NA



70.374-NA



70.378-CHA



70.867-CU



9.1050-BRGS



9.1972-BRGS

PERKINS 4248 – Agrícola

CÓDIGO BRASMECK	CÓDIGO ORIGINAL	DESCRIÇÃO	QTDE.
70.306-CC		Jogo de Juntas Motor Com Cabeçote Com Retentor	
70.306-CS		Jogo de Juntas Motor Com Cabeçote Sem Retentor	
70.306-SS		Jogo de Juntas Motor Sem Cabeçote Sem Retentor	
70.302-OIL	36.812.349	Junta do Cabeçote	1
70.019-NA	70.730.006	Gaxeta do Mancal Traseiro	2
70.035-NA	70.490.063	Junta da BBA Injetora	1
70.234-NA	36.866.722	Junta	1
70.310-KB		Kit de Borrachas	1
70.316-NA	36.815.707	Junta do Carter	1
70.320-BBS	3668C/002/003/007	Jogo de Juntas do Coletor de Admissão/Escape.	1
70.326-CB	70.490.149	Junta da Tampa de Válvulas	1
70.328-NA	36.814.127	Junta da Caixa de Distribuição	1
70.329-NA	36.813.137	Junta da Tampa da Caixa	1
70.330-NA	36.817.136	Junta da Carcaça do Bloco	1
70.331-CB	33.825.419	Junta da Tampa de Inspeção	1
70.332-NA	36.862.138	Junta do Bocal	1
70.333-NA	36.832.409	Junta da Conexão	1
70.334-NA	36.851.409	Junta da Tampa Traseira do Cabeçote	1
70.335-NA	36.853.514	Junta da Carcaça ao Cabeçote	1
70.336-NA	36.862.151	Junta da Conexão Superior da Saída D'Água	1
70.339-NA	36.862.517	Junta do Filtro Lubrificante ao Bloco e Placa	2
70.342-NA	36.851.113	Junta da BBA Alimentadora ao Bloco	1
70.343-NA	36.817.157	Junta da Carcaça ao Cabeçote	1
70.344-NA	36.862.152	Junta	1
70.345-NA	0.490.734	Junta da Carcaça do Termostato	1
70.346-NA	36.866.721	Junta da BBA D'Água	1
70.357-NA	36.832.122	Junta do Tubo BBA de Óleo	1
70.358-NA	0.490.355	Junta do Tubo da Válvula de Alívio	1
70.359-NA	36.862.523	Junta do Filtro Lubrificante ao Bloco e Placa	1
70.360-CB	36.835.425	Junta Carcaça Conexão Superior	1
70.361-NA	36.865.511	Junta da Caixa ao Adaptador Exaustor	1
70.362-PS	36.866.416	Junta do Adaptador ao Exaustor	1
70.363-CB	36.825.107	Junta da Tampa de Inspeção	1
70.364-NA	36.866.724	Junta da BBA D'Água	1
70.366-NA	70.490.146	Junta da BBA D'Água	1
70.369-NA	0.490.773	Junta da BBA Injetora	1
70.370-PS		Junta do Compressor	1
70.372-NA	36.856.102	Junta da Base da BBA de Combustível	1
70.373-NA	70.490.145	Junta da BBA D'Água	1
70.374-NA	36.834.143	Junta da BBA Injetora	1
70.378-CHA		Junta do Escapamento	1
70.867-CU		Arruela do Bico Injetor	4
9.1050-BRGS	70.730.035	Retentor Dianteiro do Virabrequim	1
9.1972-BRGS	70.730.036	Retentor Traseiro do Virabrequim	1

TODAS AS PEÇAS SÃO FORNECIDAS INDIVIDUALMENTE

PERKINS Empilhadeira Yale

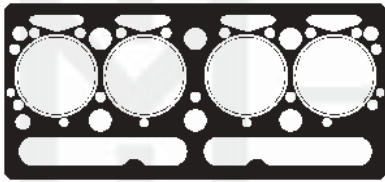

70.401-OIL



70.019-NA



70.021-BBS



70.031-NA



70.033-NA



70.035-NA



70.045-CU

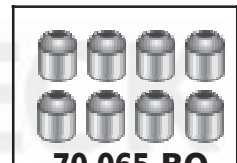

70.065-BO

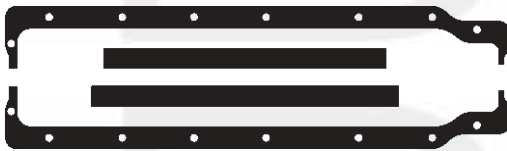

70.417-NA

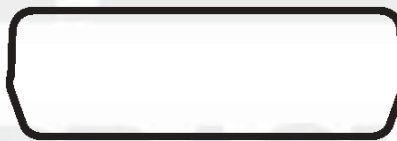

70.426-CB

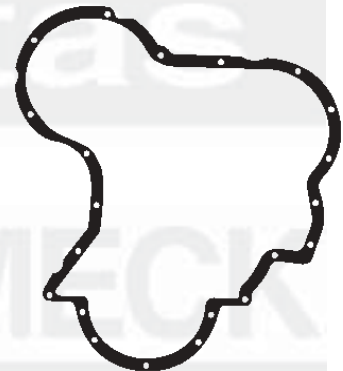

70.429-NA



70.431-NA



70.432-CB



70.436-NA



70.437-NA



70.439-NA



70.441-NA



70.443-NA



70.444-NA



70.446-BBS



70.449-NA



70.451-NA



70.458-GV



70.628-NA



70.658-NA



70.822-CU

DESENHOS FORA DE ESCALA

PERKINS 6354.2



70.201-OIL



48.441-NA



59.376-NA



70.031-NA



70.054-BO

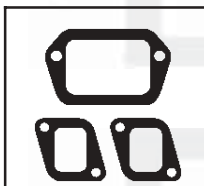

70.121-BBS



70.124-BBS



70.145-NA



70.146-NA



70.147-NA



70.148-NA



70.149-NA



70.150-NA



70.165-NA



70.216-CB



70.225-CB



70.228-NA



70.229-NA



70.230-NA



70.231-NA



70.232-NA



70.233-NA



70.235-NA



70.236-CB



70.237-GV



70.238-NA



70.239-NA



70.240-NA



70.246-NA

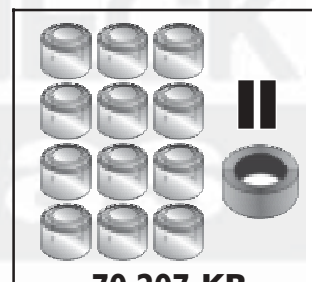

70.207-KB



70.249-NA



70.251-NA



70.252-NA



70.259-NA



70.260-CB



70.342-NA



70.343-NA



70.346-NA



70.357-NA



70.359-NA



70.363-CB



70.367-NA



70.372-NA



70.374-NA



70.859-CU



9.1050-BRGS

DESENHOS FORA DE ESCALA

PERKINS 6354.2

CÓDIGO BRASMECK	CÓDIGO ORIGINAL	DESCRIÇÃO	QTDE.
70.205-CC		Jogo de Juntas Motor Com Cabeçote Com Retentor	
70.205-CS		Jogo de Juntas Motor Com Cabeçote Sem Retentor	
70.205-SS		Jogo de Juntas Motor Sem Cabeçote Sem Retentor	
70.201-OIL	36.812.601	Junta do Cabeçote	1
48.441-NA	617.187.0180	Junta do Retorno da Turbina	1
59.376-NA	1.671.152	Junta do Cano de Retorno da Turbina	1
70.031-NA	0.490.485	Junta da Tampa da BBA Injetora	1
70.054-BO		Anel de Borracha 80 x 87,6 x 3,8 mm	1
70.121-BBS		Jogo de Juntas do Coletor de Escape	1
70.124-BBS		Jogo de Juntas do Coletor de Admissão	1
70.145-NA		Junta	1
70.146-NA		Junta da BBA de Óleo	2
70.147-NA		Junta do Filtro de Óleo	1
70.148-NA		Junta	1
70.149-NA		Junta do Tubo da Válvula de Alívio	1
70.150-NA		Junta	1
70.165-NA		Junta da BBA D'Água	1
70.207-KB		Kit de Borracha	1
70.216-CB		Junta do Carter	1
70.225-CB	36.811.438	Junta da Tampa de Válvulas	1
70.228-NA		Junta da Distribuição	1
70.229-NA		Junta da BBA de Óleo	1
70.230-NA		Junta da Tampa de Inspeção	1
70.231-NA		Junta da Válvula Termostática	1
70.232-NA		Junta do Filtro de Óleo	1
70.233-NA	36.867.132	Junta da Tampa Traseira do Coletor	1
70.235-NA		Junta do Tubo de Óleo	2
70.236-CB		Junta do Bocal do Óleo Lubrificante	3
70.237-GV		Junta do Bloco do Motor	1
70.238-NA		Junta da BBA de Óleo	1
70.239-NA	70.490.256	Junta do Filtro de Óleo	1
70.240-NA	33.828.108	Junta da Flange	1
70.246-NA		Junta da Saída do Escape.	1
70.249-GV		Junta da BBA de Óleo ao Bloco	1
70.251-NA		Junta da BBA D'Água	1
70.252-NA		Junta da BBA D'Água	1
70.259-NA		Junta da Tampa Lateral	2
70.260-CB		Junta da BBA Injetora	1
70.342-NA	36.851.113	Junta da BBA Alimentadora ao Bloco	1
70.343-NA	36.817.157	Junta da Carcaça ao Cabeçote	1
70.346-NA	36.866.721	Junta da BBA D'Água	1
70.357-NA	36.832.122	Junta do Tubo da BBA de Óleo	1
70.359-NA	36.862.523	Junta do Filtro Lubrificante ao Bloco e Placa	1
70.363-CB	36.825.107	Junta da Tampa de Inspeção	1
70.367-NA		Junta	1
70.372-NA	38.858.102	Junta da Base da BBA de Combustível	1
70.374-NA	70.490.143	Junta da BBA Injetora	1
70.867-CU		Arruela do Bico Injetor	6
9.1050-BRGS	2.415.391	Retentor da Distribuição	1

TODAS AS PEÇAS SÃO FORNECIDAS INDIVIDUALMENTE

PERKINS 6354.4



70.201-OIL



48.441-NA



59.376-NA



70.031-NA



70.054-BO



70.145-NA



70.146-NA



70.147-NA



70.148-NA



70.149-NA

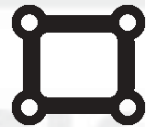

70.150-NA



70.165-NA



70.216-CB



70.220-BBS



70.226-CB



70.228-NA



70.229-NA



70.230-NA



70.231-NA



70.232-NA



70.235-NA



70.236-CB



70.237-GV



70.238-NA



70.239-NA



70.240-NA



70.246-NA



70.249-NA



70.251-NA



70.252-NA



70.259-NA



70.260-CB

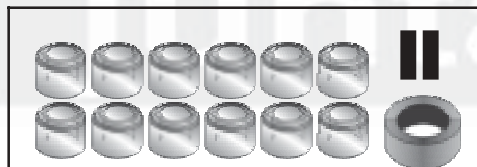

70.207-KB



70.342-NA



70.343-NA



70.346-NA



70.357-NA



70.359-NA



70.363-CB



70.367-NA



70.372-NA



70.374-NA



70.867-CU



9.1050-BRGS



9.1972-BRGS

DESENHOS FORA DE ESCALA

PERKINS 6354.4

CÓDIGO BRASMECK	CÓDIGO ORIGINAL	DESCRIÇÃO	QTDE.
70.207-CC		Jogo de Juntas Motor Com Cabeçote Com Retentor	
70.207-CS		Jogo de Juntas Motor Com Cabeçote Sem Retentor	
70.207-SS		Jogo de Juntas Motor Sem Cabeçote Sem Retentor	
70.201-OIL	36.812.601	Junta do Cabeçote	1
48.441-NA	617.187.0180	Junta do Retorno da Turbina	1
59.376-NA	1.671.152	Junta do Cano de Retorno da Turbina	1
70.031-NA	0.490.485	Junta da Tampa da BBA Injetora	1
70.054-BO		Anel de Borracha 80 x 87.6 x 3,8 mm	1
70.145-NA		Junta	1
70.146-NA		Junta da BBA de Óleo	2
70.147-NA		Junta do Filtro de Óleo	1
70.148-NA		Junta	1
70.149-NA		Junta do Tubo da Válvula de Alívio	1
70.150-NA		Junta	1
70.165-NA		Junta da BBA D'Água	1
70.207-KB		Kit de Borracha	1
70.216-CB		Junta do Carter	1
70.220-BBS		Jogo de Juntas do Escapamento	1
70.226-CB	36.811.445	Junta da Tampa de Válvulas	1
70.228-NA		Junta da Distribuição	1
70.229-NA		Junta da BBA de Óleo	1
70.230-NA		Junta da Tampa de Inspeção	1
70.231-NA		Junta da Válvula Termostática	1
70.232-NA		Junta do Filtro de Óleo	1
70.235-NA		Junta do Tubo de Óleo	2
70.236-CB		Junta do Bocal do Óleo Lubrificante	3
70.237-GV		Junta do Bloco do Motor	1
70.238-NA		Junta da BBA de Óleo	1
70.239-NA	70.490.256	Junta do Filtro de Óleo	1
70.240-NA	33.828.108	Junta da Flange	1
70.246-NA		Junta da Saída do Escape	2
70.249-GV		Junta da BBA de Óleo ao Bloco	1
70.251-NA		Junta da BBA D'Água	1
70.252-NA		Junta da BBA D'Água	1
70.259-NA		Junta da Tampa Lateral	2
70.260-CB		Junta da BBA Injetora	1
70.342-NA	36.851.113	Junta da BBA Alimentadora ao Bloco	1
70.343-NA	36.817.157	Junta da Carcaça ao Cabeçote	1
70.346-NA	36.866.721	Junta da BBA D'Água	1
70.357-NA	36.832.122	Junta do Tubo da BBA de Óleo	1
70.359-NA	36.862.523	Junta do Filtro Lubrificante ao Bloco e Placa	1
70.363-CB	36.825.107	Junta da Tampa de Inspeção	1
70.367-NA		Junta	1
70.372-NA	38.858.102	Junta da Base da BBA de Combustível	1
70.374-NA	70.490.143	Junta da BBA Injetora	1
70.867-CU		Arruela do Bico Injetor	6
9.1050-BRGS		Retentor da Distribuição	1
9.1972-BRGS		Retentor Traseiro	1

TODAS AS PEÇAS SÃO FORNECIDAS INDIVIDUALMENTE

PERKINS 6357-TA



70.901-OIL



70.019-NA



70.035-NA



70.821-BBS



70.826-CB



70.827-NA



70.831-NA



70.833-NA



70.835-NA



70.838-NA



70.843-NA



70.844-NA



70.845-NA



70.846-BBS



70.847-NA



70.859-CU



70.864-NA

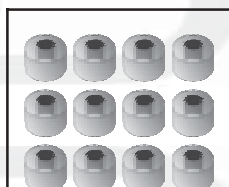

70.865-BO



70.928-NA

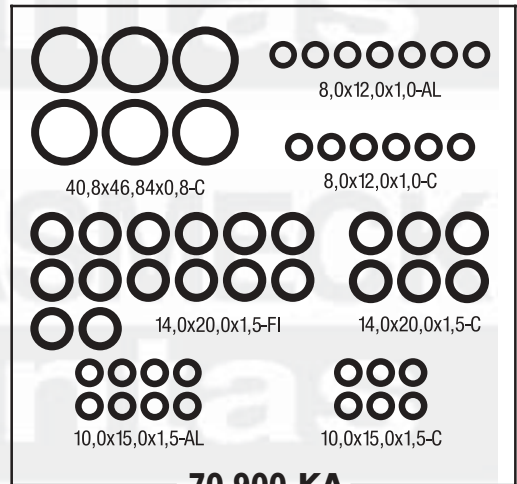

70.900-KA



70.917-NA



70.929-CB



70.934-NA



70.936-NA



70.937-NA



70.939-NA



70.941-NA



70.942-NA



70.960-NA



70.964-NA



70.967-NA



9.0586-BRG

DESENHOS FORA DE ESCALA

PERKINS 6357-V



70.901-OIL



70.019-NA



70.035-NA



70.821-BBS



70.826-CB



70.827-NA



70.831-NA



70.833-NA



70.835-NA



70.838-NA



70.843-NA



70.844-NA



70.845-NA



70.846-BBS



70.847-NA



70.859-CU



70.864-NA

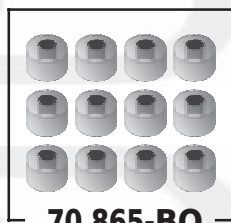

70.865-BO



70.928-NA

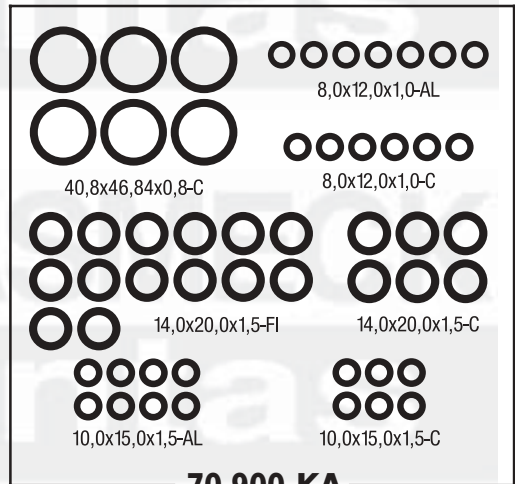

70.900-KA



70.916-CB



70.929-CB



70.934-NA



70.936-NA



70.937-NA



70.939-NA



70.941-NA



70.942-NA



70.960-NA



70.964-NA



70.967-NA



9.0586-BRG

DESENHOS FORA DE ESCALA

PERKINS 6358

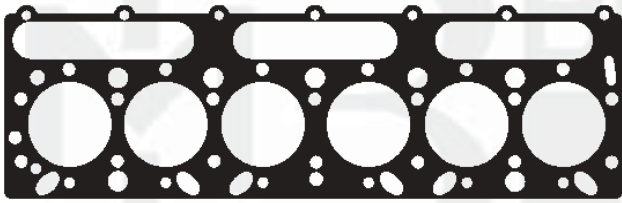

70.701-OIL



70.035-NA



70.234-NA



70.375-BO



70.459-CB



70.721-BBS



70.722-BBS



70.723-NA



70.724-NA



70.726-CB



70.728-NA



70.730-NA



70.731-NA



70.732-NA



70.733-NA



70.734-NA



70.735-NA



70.736-NA



70.737-NA



70.741-NA



70.744-NA



70.763-NA



70.827-NA



70.835-NA



70.838-NA



70.844-BBS



70.846-BBS



70.864-NA



70.867-CU



70.916-CB



70.929-CB



70.936-NA



70.937-NA



70.939-NA



70.942-NA



70.964-NA



9.1050-BRGS

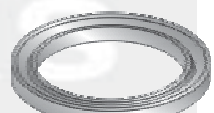

9.1972-BRGS

DESENHOS FORA DE ESCALA

MAXION HS 2.5



70.101-OIL



70.075-CH



70.078-NA



70.080-NA



70.087-NA



70.127-BO

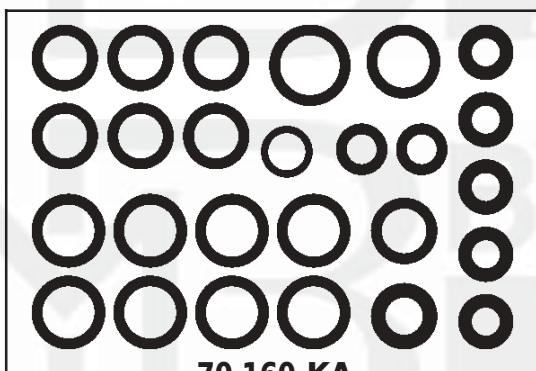

70.160-KA

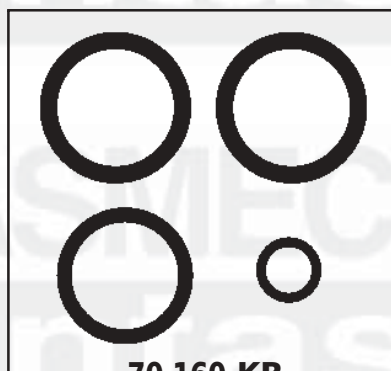

70.160-KB

DESENHOS FORA DE ESCALA

CÓDIGO BRASMECK	CÓDIGO ORIGINAL	DESCRIÇÃO	QTDE.
70.111-C		Jogo de Juntas para Retificação de Válvulas c/ Cabeçote Modelos: MBB Sprinter / Ford Ranger / G.M S-10 / Blazer	
70.111-S		Jogo de Juntas para Retificação de Válvulas s/ Cabeçote Modelos: MBB Sprinter / Ford Ranger / G.M S-10 / Blazer	
70.101-OIL		Junta do Cabeçote	1
70.075-CH	ERR-3785	Junta do Coletor Admissão / Escape.	1
70.078-NA	ERR-2378	Junta da BBA D'Água ao Bloco	2
70.080-NA	ERR-3284	Junta Carcaça da BBA D'Água	1
70.087-NA	ERR-1653	Junta do Dreno do Óleo	1
71.127-BO		Junta da Tampa de Válvulas	1
70.160-KA		Kit de Arruelas	1
70.160-KB		Kit de Borrachas	1

TODAS AS PEÇAS SÃO FORNECIDAS INDIVIDUALMENTE

PERKINS 3152 / 50X

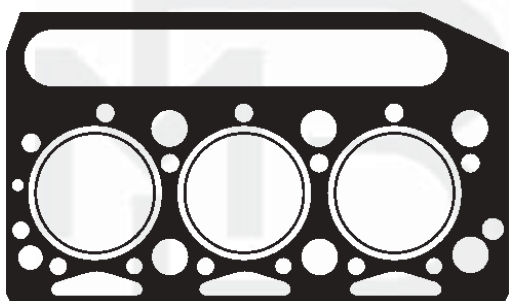

70.001-OIL



70.006-KA



70.021-BBS



70.026-CB



70.030-NA



70.031-NA



70.032-NA



70.036-NA



70.046-NA



70.065-BO



70.446-BBS

DESENHOS FORA DE ESCALA

CÓDIGO BRASMECK	CÓDIGO ORIGINAL	DESCRIÇÃO	QTDE.
70.011-C		Jogo de Juntas para Retificação de Válvulas c/ Cabeçote	
70.011-S		Jogo de Juntas para Retificação de Válvulas s/ Cabeçote	
70.001-OIL	70.490.018	Junta do Cabeçote	1
70.006-KA		Kit Arruelas	1
70.021-BBS	0.490.481	Junta do Escapamento	2
70.026-CB	0.490.491	Junta da Tampa de Válvulas	1
70.030-NA	0.490.738	Junta do Corpo da BBA Injetora	1
70.031-NA	0.490.485	Junta da Tampa BBA Injetora	1
70.032-NA	0.490.482	Junta da BBA Injetora	1
70.036-NA	0.490.184	Junta da Saída D'Água	1
70.046-NA		Junta da BBA D'Água	1
70.065-BO		Retentor de Haste de Válvulas	6
70.446-BBS	BCON-9446-A	Junta da Saída do Escapamento	1

TODAS AS PEÇAS SÃO FORNECIDAS INDIVIDUALMENTE

PERKINS 3152 Injeção Direta



70.002-OIL



70.022-BBS



70.025-CB



70.030-NA



70.031-NA



70.032-NA



70.044-NA



70.046-NA



70.047-NA



70.051-DVM



70.379-BO



70.446-BBS



70.867-CU

DESENHOS FORA DE ESCALA

CÓDIGO BRASMECK	CÓDIGO ORIGINAL	DESCRIÇÃO	QTDE.
70.012-C		Jogo de Juntas para Retificação de Válvulas c/ Cabeçote	
70.012-S		Jogo de Juntas para Retificação de Válvulas s/ Cabeçote	
70.002-OIL		Junta do Cabeçote	1
70.022-BBS	0.490.481	Junta do Coletor de Escapamento	2
70.025-CB		Junta da Tampa de Válvulas	1
70.030-NA	0.490.738	Junta do Corpo da BBA Injetora	1
70.031-NA	0.490.485	Junta da Tampa da BBA Injetora	1
70.032-NA	0.490.482	Junta da BBA Injetora	1
70.044-NA		Junta da BBA D'Água	1
70.046-NA		Junta da BBA D'Água	1
70.047-NA		Junta da Admissão	1
70.051-CH	65.583	Junta Parafuso da Tampa das Válvulas	2
70.379-BO		Borracha do Bico	3
70.446-BBS	BCON-9446-A	Junta da Saída do Escapamento	1
70.867-CU		Arruela de Bico Injetor	3

TODAS AS PEÇAS SÃO FORNECIDAS INDIVIDUALMENTE

PERKINS 1006 / 1006T



70.203-OIL



48.441-NA



70.134-NA



70.135-NA



70.140-NA



70.141-NA



70.142-NA



70.167-NA



70.219-CHA



70.221-CHA



70.222-CHA



70.223-CHA



70.227-BO



70.279-BO



70.375-BO



70.867-CU

DESENHOS FORA DE ESCALA

CÓDIGO BRASMECK	CÓDIGO ORIGINAL	DESCRIÇÃO	QTDE.
70.210-C		Jogo de Juntas para Retificação de Válvulas c/ Cabeçote	
70.210-S		Jogo de Juntas para Retificação de Válvulas s/ Cabeçote	
70.203-OIL		Junta do Cabeçote	1
48.441-NA	617.870.0180	Junta do Retorno da Turbina	1
70.134-NA	36.85R.005	Junta do Termostato	1
70.135-NA	36.85F.005	Junta do Termostato	1
70.140-NA	36.84N.008	Junta do Tubo de Escapamento	1
70.141-NA		Junta do Termostato	1
70.142-NA	36.84A.004/001	Junta do Termostato	1
70.167-NA		Junta da BBA de Óleo	1
70.219-CHA	36.88C.017	Junta Coletor de Admissão	2
70.221-CHA		Junta do Escapamento	2
70.222-CHA		Junta do Escapamento	2
70.223-CHA		Junta do Escapamento	2
70.227-BO	3681C001	Junta da Tampa de Válvulas	1
70.279-BO		Borracha do Bico Injetor	6
70.375-BO		Retentor da Haste de Válvulas	12
70.867-CU		Arruela do Bico Injetor	6

TODAS AS PEÇAS SÃO FORNECIDAS INDIVIDUALMENTE

MAXION S4 / S4T / 4.000 / 4.000T (Agrícola)



70.302-OIL



48.373-CH



48.441-NA



59.266-NA



59.376-NA



70.052-AL



70.126-BO



70.128-NA



70.154-NA



70.320-DVM



70.334-NA



70.335-NA



70.366-NA



70.368-BBS



70.392-CH



70.859-CU

DESENHOS FORA DE ESCALA

CÓDIGO BRASMECK	CÓDIGO ORIGINAL	DESCRIÇÃO	QTDE.
70.112-C		Jogo de Juntas para Retificação de Válvulas c/ Cabeçote	
70.112-S		Jogo de Juntas para Retificação de Válvulas s/ Cabeçote	
70.302-OIL		Junta do Cabeçote	1
48.373-CH	TAF.145.453	Junta da Base da Turbina	1
48.441-NA	617.187.0180	Junta do Retorno da Turbina	1
59.266-NA	1.671.153	Junta da Lubrificação da Turbina	1
59.376-NA	1.671.152	Junta do Cano de Retorno da Turbina	1
70.052-CU		Arruela do Bico Injetor 7,1x14,9x1,5mm	4
70.126-BO	70.490.258	Junta da Tampa de Válvulas	1
70.128-NA	70.490.257	Junta da Curva da Admissão	1
70.154-NA	36.832.118	Junta do Pescador	1
70.320-BBS	3668C-002/003/007	Jogo de Juntas do Coletor de Admissão/Escape	1
70.334-NA	36.851.409	Junta da Tampa Traseira do Cabeçote	1
70.335-NA	36.853.514	Junta da Carcaça ao Cabeçote	1
70.366-NA	70.490.146	Junta da BBA D'Água	1
70.368-BBS	36.822.111	Junta da Saída do Escape	2
70.392-CH	70.490.283	Junta do Caracol	1
70.859-CU	0.490.301	Gaxeta do Escapamento	1

TODAS AS PEÇAS SÃO FORNECIDAS INDIVIDUALMENTE

PERKINS 4203 Injeção Indireta (MF 65 / 8BR)



70.401-OIL



70.021-BBS



70.031-NA



70.045-CU



70.065-BO



70.426-CB



70.431-NA



70.433-CB



70.434-CB



70.439-NA



70.441-NA



70.449-NA



70.559-BBS



70.822-CU

DESENHOS FORA DE ESCALA

CÓDIGO BRASMECK	CÓDIGO ORIGINAL	DESCRIÇÃO	QTDE.
70.511-C		Jogo de Juntas para Retificação de Válvulas c/ Cabeçote	
70.511-S		Jogo de Juntas para Retificação de Válvulas s/ Cabeçote	
70.401-OIL	BCON-6051-A	Junta do Cabeçote	1
70.021-BBS	0.490.481	Junta do Escapamento	2
70.031-NA	0.490.485	Junta da Tampa da BBA Injetora	1
70.045-CU	0.490.115	Arruela de Cobre	4
70.065-BO		Retentor da Haste de Válvulas	8
70.426-CB	BCON-6584-A	Junta da Tampa de Válvulas	1
70.431-NA	BCON-9441-A	Junta da Admissão e Escape	1
70.433-CB	BCON-6585-A	Junta da Tampa Dianteira Inspeção de Válvulas	1
70.434-CB	BCON-6586-A	Junta da Tampa Traseira Inspeção de Válvulas	1
70.439-NA	BCON-8255-A	Junta da Saída D'Água do Cilindro	1
70.441-NA	BCON-8595-A	Junta da Saída D'Água	1
70.449-NA	BCON-8596-A	Junta Passagem Lateral D'Água	1
70.559-BBS	80.490.032	Junta da Saída do Escapamento	1
70.822-CU	0.920.113	Arruela de Cobre	4

TODAS AS PEÇAS SÃO FORNECIDAS INDIVIDUALMENTE

PERKINS 4203 – Injeção Direta 65X

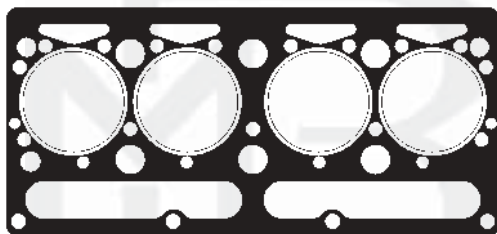

70.601-OIL



70.031-NA



70.065-BO



70.439-NA



70.441-NA



70.446-BBS



70.449-NA



70.621-BBS



70.622-BBS



70.626-CB



70.631-NA



70.823-CU

DESENHOS FORA DE ESCALA

CÓDIGO BRASMECK	CÓDIGO ORIGINAL	DESCRIÇÃO	QTDE.
70.611-C		Jogo de Juntas para Retificação de Válvulas c/ Cabeçote	
70.611-S		Jogo de Juntas para Retificação de Válvulas s/ Cabeçote	
70.601-OIL	36.812.126	Junta do Cabeçote	1
70.031-NA	0.490.485	Junta da Tampa da BBA Injetora	1
70.065-BO		Retentor da Haste de Válvulas	8
70.439-NA	BCON-8255-A	Junta da Saída D'Água do Cilindro	1
70.441-NA	BCON-8595-A	Junta da Saída D'Água	1
70.446-BBS	BCON-9446-A	Junta da Saída do Escapamento	1
70.449-NA	BCON-8596	Junta da Passagem Lateral D'Água	1
70.621-BBS	036.937.409	Junta do Coletor de Escapamento	2
70.622-BBS	70.540.015	Junta do Coletor Escapamento	2
70.626-CB	36.911.112	Junta da Tampa de Válvulas	1
70.631-NA	36.867.116	Junta da Tubagem Admissão	1
70.823-CU	0.921.173	Arruela do Bico Injetor	4

TODAS AS PEÇAS SÃO FORNECIDAS INDIVIDUALMENTE

PERKINS 4236 Turbo / MF 292



70.302-OIL



70.320-BBS



70.326-BO



70.334-NA



70.335-NA



70.336-NA



70.338-BO



70.345-NA



70.360-CB



70.366-NA



70.375-BO



70.378-CHA



70.867-CU

DESENHOS FORA DE ESCALA

CÓDIGO BRASMECK	CÓDIGO ORIGINAL	DESCRIÇÃO	QTDE.
70.110-C		Jogo de Juntas para Retificação de Válvulas c/ Cabeçote	
70.110-S		Jogo de Juntas para Retificação de Válvulas s/ Cabeçote	
70.302-OIL		Junta do Cabeçote	1
70.320-BBS	3668C-002/003/007	Jogo de Juntas do Coletor de Admissão/Escape	1
70.326-CB	70.490.149	Junta da Tampa de Válvulas	1
70.334-NA	36.851.409	Junta da Tampa Traseira do Cabeçote	1
70.335-NA	36.853.514	Junta da Carcaça ao Cabeçote	1
70.336-NA	36.862.151	Junta da Conexão Superior da Saída D'Água	1
70.338-BO	33.811.113	Anel de Vedação Tubo de Lubrificação	1
70.345-NA	0.490.734	Junta da Carcaça do Termostato	1
70.360-CB	36.835.425	Junta da Carcaça Conexão Superior	1
70.366-NA	70.490.146	Junta da BBA D'Água	1
70.378-CHA	1.877.671	Junta do Escapamento	1
70.375-BO		Retentor da Haste de Válvulas	8
70.867-CU		Arruela do Bico Injetor	3

TODAS AS PEÇAS SÃO FORNECIDAS INDIVIDUALMENTE

PERKINS 4236 (Veicular / Agrícola / Q20B)

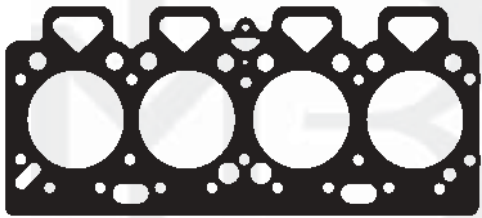

70.302-OIL



70.310-KB

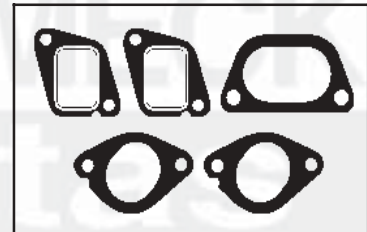

70.320-BBS



70.326-CB



70.334-NA



70.335-NA



70.336-NA



70.345-NA



70.360-CB



70.366-NA



70.368-BBS



70.859-CU



70.867-CU

DESENHOS FORA DE ESCALA

CÓDIGO BRASMECK	CÓDIGO ORIGINAL	DESCRIÇÃO	QTDE.
70.312-C		Jogo de Juntas para Retificação de Válvulas c/ Cabeçote	
70.312-S		Jogo de Juntas para Retificação de Válvulas s/ Cabeçote	
70.302-OIL	36.812.349	Junta do Cabeçote	1
70.310-KB		Kit de Borracha	1
70.320-BBS	3668C/002/003/007	Jogo de Juntas do Coletor de Admissão/Escape.	1
70.326-CB	70.490.149	Junta da Tampa de Válvulas	1
70.334-NA	36.851.409	Junta da Tampa Traseira do Cabeçote	1
70.335-NA	36.853.514	Junta da Carcaça ao Cabeçote	1
70.336-NA	36.862.151	Junta da Conexão Superior da Saída D'Água	1
70.345-NA	0.490.734	Junta da Carcaça do Termostato	1
70.360-CB	36.835.425	Junta da Carcaça Conexão Superior	1
70.366-NA	70.490.146	Junta da BBA D'Água	1
70.368-BBS	36.822.111	Junta da Saída do Escape	2
70.859-CU	0.490.301	Gaxeta do Escapamento	1
70.867-CU	70.920.081	Arruela do Bico Injetor	4

TODAS AS PEÇAS SÃO FORNECIDAS INDIVIDUALMENTE

PERKINS 4248

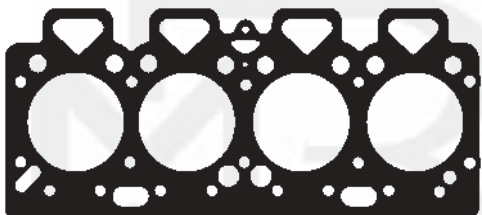

70.302-OIL



70.320-BBS



70.326-CB



70.334-NA



70.335-NA



70.336-NA



70.338-BO



70.345-NA



70.360-CB



70.366-NA



70.375-BO



70.378-CHA



70.867-CU

DESENHOS FORA DE ESCALA

CÓDIGO BRASMECK	CÓDIGO ORIGINAL	DESCRIÇÃO	QTDE.
70.311-C		Jogo de Juntas para Retificação de Válvulas c/ Cabeçote	
70.311-S		Jogo de Juntas para Retificação de Válvulas s/ Cabeçote	
70.302-OIL	36.812.349	Junta do Cabeçote	1
70.320-BBS	3668C/002/003/007	Jogo de Juntas do Coletor de Admissão/Escape.	1
70.326-CB	70.490.149	Junta da Tampa de Válvulas	1
70.334-NA	36.851.409	Junta da Tampa Traseira do Cabeçote	1
70.335-NA	36.853.514	Junta da Carcaça ao Cabeçote	1
70.336-NA	36.862.151	Junta da Conexão Superior da Saída D'Água	1
70.338-BO	33.811.113	Anel de Vedação Tubo de Lubrificação	1
70.345-NA	0.490.734	Junta da Carcaça do Termostato	1
70.360-CB	36.835.425	Junta da Carcaça Conexão Superior	1
70.366-NA	70.490.146	Junta da BBA D'Água	1
70.375-BO	36.817.117	Retentor da Haste de Válvulas	8
70.378-CHA	1.877.691	Junta do Escapamento	1
70.867-CU		Arruela do Bico Injetor	4

TODAS AS PEÇAS SÃO FORNECIDAS INDIVIDUALMENTE

PERKINS 6354.2



70.201-OIL



48.441-NA



59.376-NA



70.031-NA

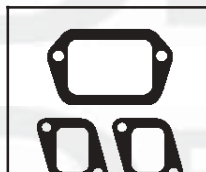

70.121-BBS



70.124-BBS



70.165-NA



70.225-CB



70.230-NA



70.231-NA



70.236-CB

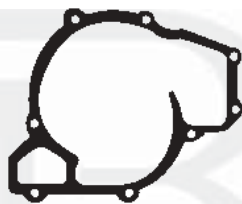

70.251-NA



70.252-NA



70.338-BO



70.375-BO



70.867-CU

DESENHOS FORA DE ESCALA

CÓDIGO BRASMECK	CÓDIGO ORIGINAL	DESCRIÇÃO	QTDE.
70.209-C		Jogo de Juntas para Retificação de Válvulas c/ Cabeçote	
70.209-S		Jogo de Juntas para Retificação de Válvulas s/ Cabeçote	
70.201-OIL	36.812.601	Junta do Cabeçote	1
48.441-NA	617.187.0180	Junta do Retorno da Turbina	1
59.376-NA	1.671.152	Junta do Cano Retorno da Turbina	1
70.031-NA	0.490.485	Junta da Tampa BBA Injetora	1
70.121-BBS		Jogo de Juntas do Coletor de Escape	1
70.124-BBS		Jogo de Juntas do Coletor de Admissão	1
70.165-NA		Junta da BBA D'Água	1
70.225-CB	36.811.445	Junta da Tampa de Válvulas	1
70.230-NA		Junta da Tampa de Inspeção	1
70.231-NA		Junta da Válvula Termostática	1
70.236-CB		Junta do Bocal do Óleo Lubrificante	3
70.251-NA		Junta da BBA D'Água	1
70.252-NA		Junta da BBA D'Água	1
70.338-BO	33.811.113	Anel de Vedação Tubo Lubrificação	1
70.375-BO	36.817.117	Retentor da Haste de Válvulas	12
70.867-CU		Arruela do Bico Injetor	6

TODAS AS PEÇAS SÃO FORNECIDAS INDIVIDUALMENTE

PERKINS 6354.4



70.201-OIL



48.441-NA



59.376-NA



70.031-NA



70.165-NA



70.220-BBS



70.226-CB



70.230-NA



70.231-NA



70.236-CB

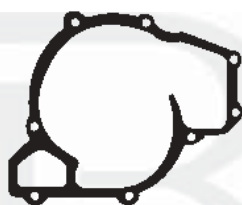

70.251-NA



70.252-NA



70.338-BO



70.375-BO



70.867-CU

DESENHOS FORA DE ESCALA

CÓDIGO BRASMECK	CÓDIGO ORIGINAL	DESCRIÇÃO	QTDE.
70.211-C		Jogo de Juntas para Retificação de Válvulas c/ Cabeçote	
70.211-S		Jogo de Juntas para Retificação de Válvulas s/ Cabeçote	
70.201-OIL	36.812.601	Junta do Cabeçote	1
48.441-NA	617.187.0180	Junta do Retorno da Turbina	1
59.376-NA	1.671.152	Junta do Cano Retorno da Turbina	1
70.031-NA	0.490.485	Junta da Tampa BBA Injetora	1
70.165-NA		Junta da BBA D'Água	1
70.220-BBS		Jogo de Juntas do Escapamento	1
70.226-CB	36.811.445	Junta da Tampa de Válvulas	1
70.230-NA		Junta da Tampa de Inspeção	1
70.231-NA		Junta da Válvula Termostática	1
70.236-CB		Junta do Bocal do Óleo Lubrificante	3
70.251-NA		Junta da BBA D'Água	1
70.252-NA		Junta da BBA D'Água	1
70.338-BO	33.811.113	Anel de Vedação Tubo Lubrificação	1
70.375-BO	36.817.117	Retentor da Haste de Válvulas	12
70.867-CU		Arruela do Bico Injetor	6

TODAS AS PEÇAS SÃO FORNECIDAS INDIVIDUALMENTE

PERKINS 6357 Veicular / Agrícola



70.901-OIL



70.821-BBS



70.827-NA



70.831-NA



70.833-NA



70.835-NA



70.845-NA



70.846-BBS



70.847-NA

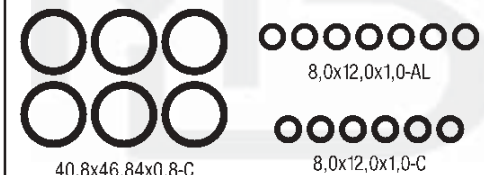

70.900-KA



70.859-CU



70.826-CB

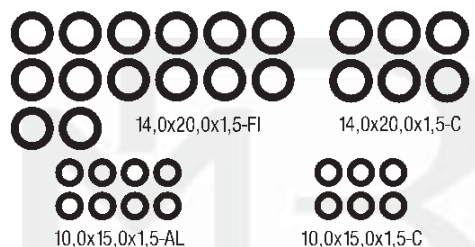

70.864-NA



70.865-BO



70.967-NA

DESENHOS FORA DE ESCALA

CÓDIGO BRASMECK	CÓDIGO ORIGINAL	DESCRIÇÃO	QTDE.
70.911-C		Jogo de Juntas para Retificação de Válvulas c/ Cabeçote	
70.911-S		Jogo de Juntas para Retificação de Válvulas s/ Cabeçote	
70.901-OIL		Junta do Cabeçote	1
70.821-BBS	0.490.675	Junta do Coletor de Escapamento	3
70.826-CB	70.490.139	Junta da Tampa de Válvulas	1
70.827-NA	70.490.101	Junta da Cobertura Câmara D'Água	2
70.831-NA	70.490.087	Junta Admissão de Escapamento	1
70.833-NA	0.490.676	Junta do Termostato	1
70.835-NA	0.490.736	Junta da Conexão Entrada D'Água/Bloco	1
70.845-NA	0.490.307	Junta do Corpo Admissão de Ar	1
70.846-BBS	0.490.433	Junta da Saída do Escapamento	1
70.847-NA	0.490.300	Junta da Tampa Traseira do Cabeçote	1
70.859-CU	0.490.301	Gaxeta do Escapamento	1
70.864-NA	70.490.050	Junta da BBA D'Água a Placa Traseira	1
70.865-BO	33.817.402	Retentor de Haste de Válvulas	12
70.900-KA		Kit Arruelas	1
70.967-NA	70.490.071	Junta da Válvula Termostática	1

TODAS AS PEÇAS SÃO FORNECIDAS INDIVIDUALMENTE

PERKINS 6358

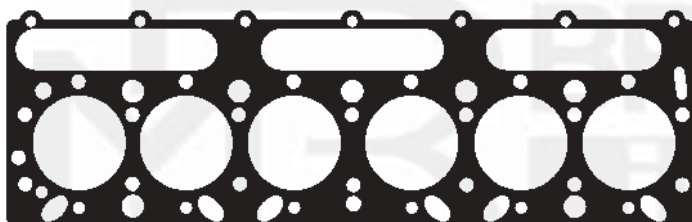

70.701-OIL



70.375-BO



70.721-BBS



70.722-BBS



70.723-NA



70.724-NA



70.726-CB



70.730-NA



70.731-NA



70.736-NA



70.827-NA



70.835-NA



70.846-BBS



70.864-NA



70.867-CU

DESENHOS FORA DE ESCALA

CÓDIGO BRASMECK	CÓDIGO ORIGINAL	DESCRIÇÃO	QTDE.
70.711-C		Jogo de Juntas para Retificação de Válvulas c/ Cabeçote	
70.711-S		Jogo de Juntas para Retificação de Válvulas s/ Cabeçote	
70.701-OIL		Junta do Cabeçote	1
70.375-BO	33.817.117	Retentor de Haste de Válvulas	12
70.721-BBS	70.490.107	Junta do Cotovelo Coletor de Escapamento	2
70.722-BBS	70.490.106	Junta do Corpo Central Coletor Escapamento	1
70.723-NA	70.490.117	Junta do Coletor de Admissão	2
70.724-NA	70.490.118	Junta do Coletor de Admissão	2
70.726-CB	70.490.096	Junta da Tampa de Válvulas	1
70.730-NA	70.490.116	Junta da Carcaça do Termostato	1
70.731-NA	70.490.119	Junta da Conexão Superior a Carcaça	1
70.736-NA	70.490.114	Junta da Tampa Traseira ao Cabeçote	1
70.827-NA	70.490.101	Junta da Cobertura Câmara D'Água	2
70.835-NA	0.490.736	Junta da Conexão Entrada BBA D'Água	1

TODAS AS PEÇAS SÃO FORNECIDAS INDIVIDUALMENTE



TECNOLOGIA ORIGINAL EM PEÇAS DE REPOSIÇÃO



L-75 / 76 / 110 – Motor Nacional Ônibus / Caminhão (63/76)



59.601-OIL

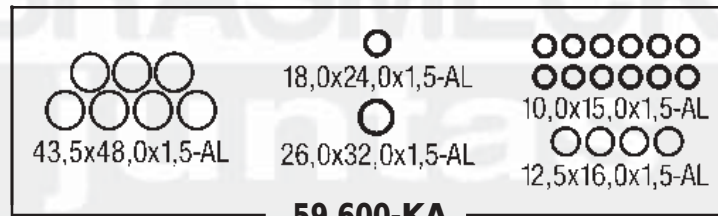

43,5x48,0x1,5-AL

18,0x24,0x1,5-AL

26,0x32,0x1,5-AL

10,0x15,0x1,5-AL

12,5x16,0x1,5-AL

59.600-KA

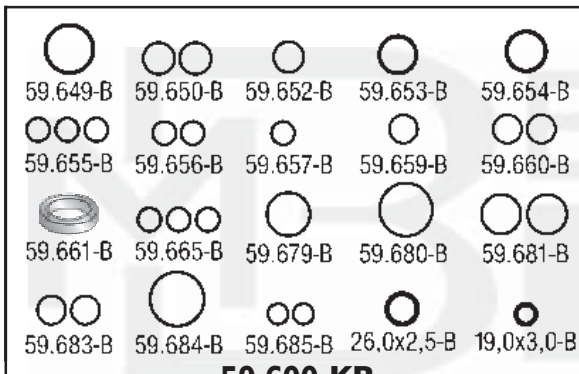

59.649-B

59.650-B

59.652-B

59.653-B

59.654-B

59.655-B

59.656-B

59.657-B

59.659-B

59.660-B

59.661-B

59.665-B

59.679-B

59.680-B

59.681-B

59.683-B

59.684-B

59.685-B

26,0x2,5-B

19,0x3,0-B

59.600-KB



59.616-NA



59.626-CB

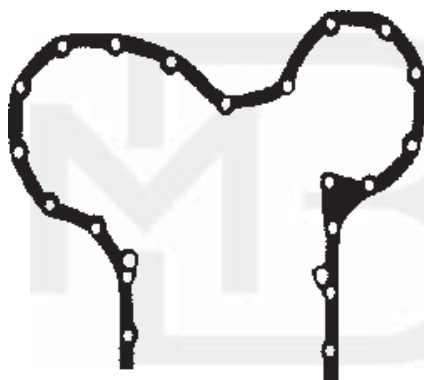

59.628-GV



59.629-GV



59.627-NA



59.630-NA



59.631-GV



59.632-GV



59.633-GV



59.634-GV



59.635-GV



59.636-GV



59.637-GV



59.638-GV



59.639-PS



59.640-GV



59.643-NA



59.644-NA



59.646-NA



59.688-NA



59.690-GV



59.692-NA



59.693-BO



59.721-CHAC



59.722-CHAC



9.2069-S



9.2235-S

L-111 / L-112 Ônibus B-76 (76/89)



59.701-OIL



59.533-PS



59.616-NA



59.626-CB



59.628-GV



59.629-GV



59.630-NA



59.627-NA



59.631-GV



59.632-GV



59.633-GV



59.634-GV



59.635-GV



59.636-GV



59.637-GV



59.638-GV



59.639-PS



59.640-GV



59.643-NA



59.644-NA



59.646-NA



59.690-GV

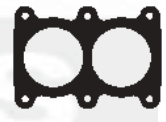

59.692-NA



59.693-BO



59.699-NA

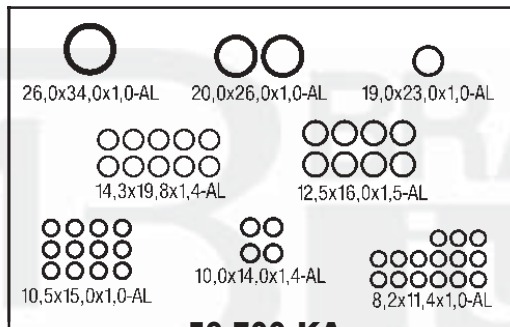

59.700-KA

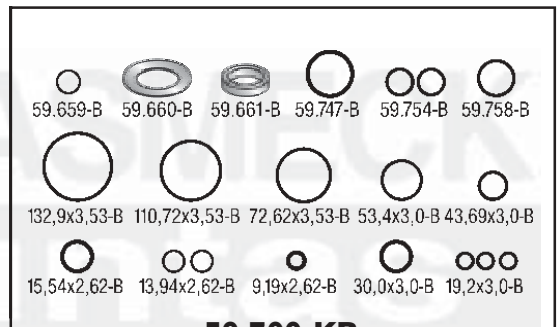

59.700-KB



59.721-CHAC



59.722-CHAC



59.729-GV



59.730-NA



59.731-NA



59.734-GV



59.735-GV



59.736-GV



59.756-GV



59.938-NA



9.2069-S

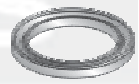

9.2235-S

L-111 / L-112 Ônibus B-76 (76/89)

CÓDIGO BRASMECK	CÓDIGO ORIGINAL	DESCRIÇÃO	QTDE.
59.706-CC		Jogo de Juntas do Motor Com Cabeçote Com Retentores Com Anéis da Camisa	
59.706-CS		Jogo de Juntas do Motor Com Cabeçote Sem Retentores Sem Anéis da Camisa	
59.706-SS		Jogo de Juntas do Motor Sem Cabeçote Sem Retentores Sem Anéis da Camisa	
59.701-OIL	271.980	Junta do Cabeçote	2
59.533-PS	225.835	Junta da Tampa da BBA de Óleo	1
59.616-NA	215.242	Jogo de Juntas do Carter	1
59.626-CB	258.459	Junta da Tampa de Válvulas	1
59.627-NA	277.632	Junta do Coletor de Admissão	2
59.628-GV	287.553	Junta da Tampa Dianteira de Distribuição	1
59.629-GV	287.554	Junta da Tampa Interna de Distribuição	1
59.630-NA	181.333	Junta da Tampa Lateral	2
59.631-GV	139.028	Junta da Tampa do Carter	1
59.632-GV	231.795	Junta da Carcaça da BBA D'Água	1
59.633-GV	302.226	Junta da Tampa de Distribuição	1
59.634-GV	139.274	Junta da Tampa da Distribuição	1
59.635-GV	139.108	Junta do Coletor de Admissão	1
59.636-GV	35.309	Junta Respiro dos Tuchos	1
59.637-GV	131.305	Junta do Suporte do Dinamo	1
59.638-GV	35.161	Junta da BBA D'Água	1
59.639-PS	139.123	Junta do Suporte do Balanceiro	6
59.640-GV	139.044	Junta do Termostato	1
59.643-NA	152.667	Junta do Coletor Escape	1
59.644-NA	291.826	Junta do Termostato	2
59.646-NA	278.602	Junta da Passagem D'Água	1
59.690-GV	287.555	Junta da Carcaça do Volante	1
59.692-NA	141.920	Junta do Corpo do Compressor	1
59.693-BO		Anéis da Camisa	18
59.699-NA	232.961	Junta do Rotativo	1
59.700-KA		Kit de Arruelas	1
59.700-KB		Kit de Anéis de Borracha	1
59.721-CHAC	277.272	Junta do Escape.	2
59.722-CHAC	277.273	Junta do Escape.	2
59.729-GV	292.759	Junta do Tubo da Entrada D'Água	1
59.730-NA	238.403	Junta do Filtro	1
59.731-NA	183.938	Junta do Cano de Escape.	1
59.734-GV	235.610	Junta do Tubo de Retorno de Óleo	1
59.735-GV	238.148	Junta do Termostato	1
59.736-GV		Junta do Tubo Retorno de Óleo	1
59.756-GV	277.637	Junta do Abafador	1
59.938-NA	170.765	Junta da Carcaça do Filtro Rotativo	1
9.2069-S	275.591	Retentor Dianteiro do Virabrequim	1
9.2235-S	231.938	Retentor Traseiro do Virabrequim	1

TODAS AS PEÇAS SÃO FORNECIDAS INDIVIDUALMENTE

HW 112/113 – DN / DS / DSC11 (82/...)



59.701-OIL



59.264-NA



59.270-DVM



59.521-NA



59.522-NA



59.533-PS



59.546-NA



59.616-NA



59.626-CB



59.627-NA

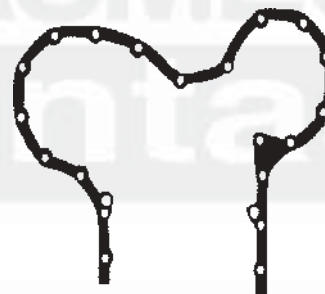

59.628-GV



59.629-GV



59.630-NA



59.632-GV



59.633-GV



59.636-GV



59.637-GV



59.638-GV



59.639-PS



59.644-NA



59.646-NA



59.655-NA



59.678-NA



59.690-GV



59.692-NA



59.693-BO



59.699-NA

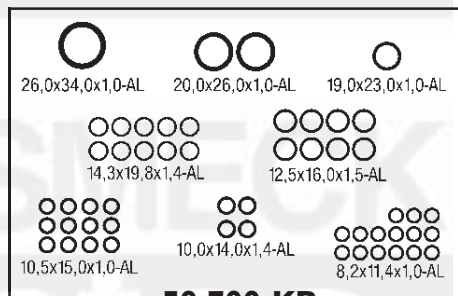

59.700-KB

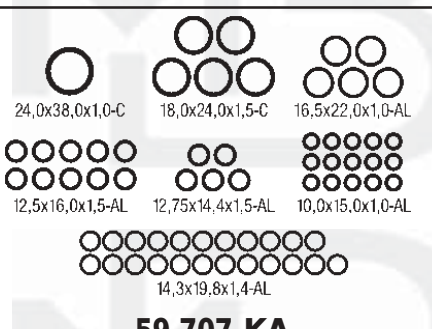

59.707-KA



59.720-BBS



59.724-BBS



59.728-NA



59.734-GV



59.729-GV



59.730-NA



59.735-GV



59.736-GV



59.748-NA



59.756-GV



59.766-NA



59.938-NA



59.997-GV



9.2069-S



9.2235-S

HW 112/113 – DN / DS / DSC11 (82/...)

CÓDIGO BRASMECK	CÓDIGO ORIGINAL	DESCRIÇÃO	QTDE.
59.707-CC		Jogo de Juntas do Motor Com Cabeçote Com Retentores Com Anéis da Camisa	
59.707-CS		Jogo de Juntas do Motor Com Cabeçote Sem Retentores Sem Anéis da Camisa	
59.707-SS		Jogo de Juntas do Motor Sem Cabeçote Sem Retentores Sem Anéis da Camisa	
59.701-OIL	271.980	Junta do Cabeçote	2
59.264-NA	139.471	Junta do Tubo Lubrificador da Turbina Superior	3
59.270-DVM		Jogo de Juntas da Turbina	1
59.521-NA	1.675.583-B	Junta da Admissão	4
59.522-NA	1.675.584-B	Junta da Admissão	2
59.533-PS	225.835	Junta da Tampa da BBA de Óleo	1
59.546-NA	332.598	Junta do Suporte da BBA Hidráulica	1
59.616-NA	215.242	Jogo de Juntas do Carter	1
59.626-CB	258.459	Junta da Tampa de Válvulas	2
59.627-NA	277.632	Junta do Coletor de Admissão	2
59.628-GV	287.553	Junta da Tampa Dianteira da Distribuição	1
59.629-GV	287.554	Junta da Tampa Interna da Distribuição	1
59.630-NA	181.333	Junta da Tampa Lateral	2
59.632-GV	231.795	Junta da Carcaça da BBA D'Água	1
59.633-GV	302.226	Junta da Tampa de Distribuição	1
59.636-GV	35.309	Junta Respiro dos Tuchos	1
59.637-GV	131.305	Junta do Suporte do Dinamo	1
59.638-GV	35.161	Junta da BBA D'Água	1
59.639-PS	139.123	Junta do Suporte do Balanceiro	6
59.644-NA	291.826	Junta do Termostato	2
59.646-NA	278.602	Junta da Passagem D'Água	1
59.655-NA	287.789	Junta Tubo Saída do Escape	1
59.678-NA	272.793	Junta da Tampa do Mediador de Óleo	1
59.690-GV	287.555	Junta da Carcaça do Volante	1
59.692-NA	141.920	Junta do Corpo do Compressor	1
59.693-BO		Anéis da Camisa	18
59.699-NA	23.961	Junta do Rotativo	1
59.700-KB		Kit de Anéis de Borracha	1
59.707-KA		Kit de Arruelas	1
59.720-BBS	1.109.288	Junta do Coletor	2
59.724-BBS	378.264	Junta do Coletor	2
59.728-NA	1.675.602	Junta da Tampa Interna de Distribuição	1
59.729-GV	292.759	Junta do Tubo de Entrada D'Água	1
59.730-NA	238.403	Junta do Filtro	1
59.734-GV	235.610	Junta do Tubo de Retorno de Óleo	1
59.735-GV	238.148	Junta do Termostato	1
59.736-GV		Junta do Tubo Retorno de Óleo	1
59.748-NA		Junta	1
59.756-GV	277.635	Junta do Adaptador	1
59.766-NA	1.671.154	Junta da Admissão	1
59.938-NA	170.765	Junta da Carcaça do Filtro Rotativo	1
59.997-GV		Junta	1
9.2069-S	275.591	Retentor Dianteiro do Virabrequim	1
9.2235-S	231.938	Retentor Traseiro do Virabrequim	1

TODAS AS PEÇAS SÃO FORNECIDAS INDIVIDUALMENTE

HW 1990



59.701-OIL



59.264-NA



59.265-NA



59.533-PS



59.616-NA



59.626-CB

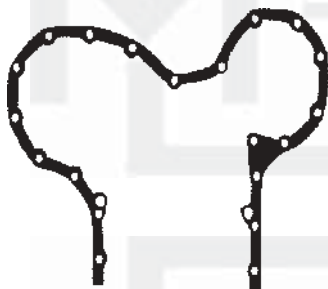

59.628-GV



59.629-GV



59.630-NA



59.632-GV



59.634-GV



59.636-GV



59.638-GV



59.643-NA



59.644-NA



59.680-GV



59.690-GV



59.693-BO



59.699-NA

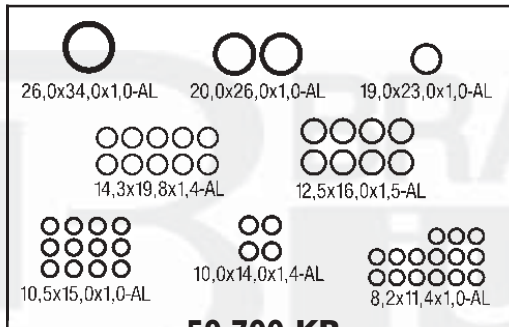

59.700-KB

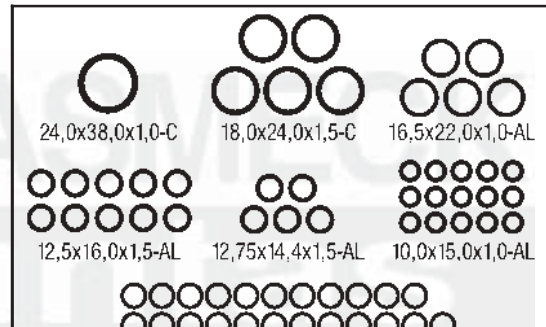

59.707-KA



59.720-BBS

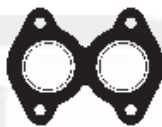

59.724-BBS



59.729-GV



59.730-NA



59.731-NA



59.732-NA



59.733-GV



59.734-GV



59.735-GV



9.2069-S



9.2235-S

Unificados 111/112 HW 112/113 – DN / DS / DSC



59.701-OIL

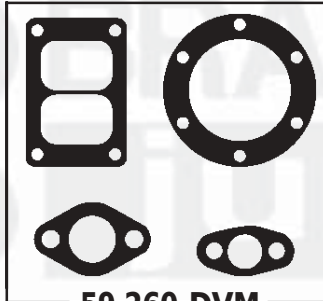

59.260-DVM

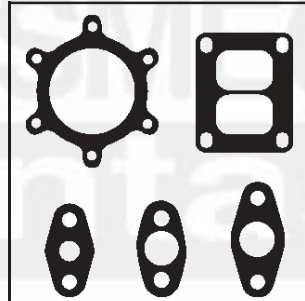

59.270-DVM



59.521-NA



59.522-NA



59.533-PS



59.547-GV



59.546-GV



59.616-NA



59.624-NA



59.626-CB



59.628-GV



59.630-NA



59.632-GV



59.627-NA



59.633-GV



59.636-GV



59.644-NA



59.645-NA



59.646-NA



59.655-NA



59.678-NA



59.690-GV



59.693-BO



59.699-NA

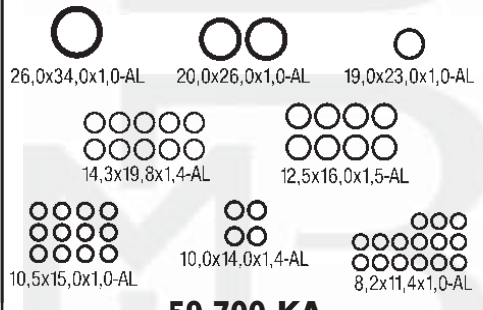

59.700-KA

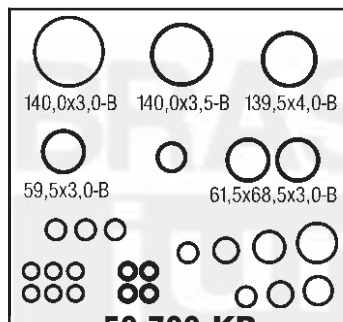

59.700-KB

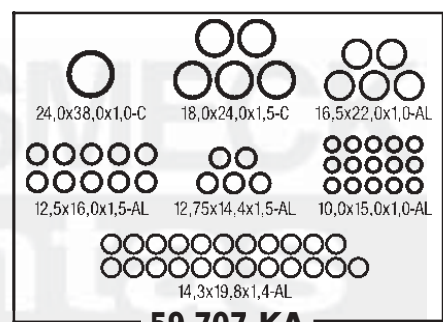

59.707-KA



59.720-BBS

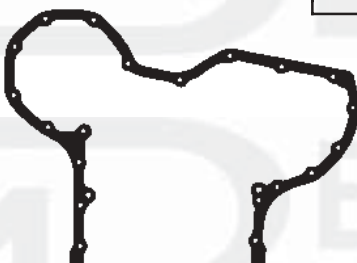

59.728-NA



59.724-BBS



59.729-GV



59.730-NA



59.736-GV



59.740-GV



59.748-GV



59.836-NA



59.938-NA



9.1949-S



9.2069-S



9.2235-S

Unificados 111/112 HW 112/113 – DN / DS / DSC

CÓDIGO BRASMECK	CÓDIGO ORIGINAL	DESCRIÇÃO	QTDE.
59.708-CC		Jogo de Juntas do Motor Com Cabeçote Com Retentores Com Anéis da Camisa	
59.708-CS		Jogo de Juntas do Motor Com Cabeçote Sem Retentores Sem Anéis da Camisa	
59.708-SS		Jogo de Juntas do Motor Sem Cabeçote Sem Retentores Sem Anéis da Camisa	
59.701-OIL	271.980	Junta do Cabeçote	2
59.260-DVM		Jogo de Juntas da Turbina	1
59.270-DVM		Jogo de Juntas da Turbina	1
59.521-NA	1.675.583-B	Junta da Admissão	1
59.522-NA	1.675.584-B	Junta da Admissão	1
59.533-PS	225.835	Junta da Tampa da BBA de Óleo	1
59.546-GV	332.598	Junta do Suporte da BBA Hidráulica	1
59.547-GV		Junta	1
59.616-NA	215.242	Jogo de Juntas do Carter	1
59.624-NA	338.332	Junta de Admissão	1
59.626-CB	258.459	Junta da Tampa de Válvulas	2
59.627-NA	277.632	Junta do Coletor de Admissão	2
59.628-GV	287.553	Junta da Tampa Dianteira da Distribuição	1
59.630-NA	181.333	Junta da Tampa Lateral	2
59.632-GV	231.795	Junta da Carcaça da BBA D'Água	1
59.633-GV	302.226	Junta da Tampa de Distribuição	1
59.636-GV	35.309	Junta Respiro dos Tuchos	2
59.644-NA	291.826	Junta do Termostato	2
59.645-NA		Junta	1
59.646-NA	278.602	Junta da Passagem D'Água	1
59.655-NA	1.676.941	Junta Tubo Saída do Escape	1
59.678-NA	272.793	Junta da Tampa do Mediador de Óleo	1
59.690-GV	287.555	Junta da Carcaça do Volante	1
59.693-BO		Anéis da Camisa	18
59.699-NA	232.961	Junta do Rotativo	1
59.700-KB		Kit de Anéis de Borracha	1
59.700-KA		Kit de Arruelas	1
59.707-KA		Kit de Arruelas	1
59.720-BBS	1.109.288	Junta do Coletor	1
59.724-BBS	378.264	Junta do Coletor	1
59.728-NA	1.675.602	Junta da Caixa Interna de Distribuição	1
59.729-GV	292.759	Junta do Tubo de Entrada D'Água	1
59.730-NA	238.403	Junta do Filtro	1
59.736-GV		Junta do Tubo Retorno de Óleo	1
59.740-GV	278.334	Junta do Termostato	1
59.748-GV		Junta	1
59.836-NA		Junta	1
59.938-NA	170.765	Junta da Carcaça do Filtro Rotativo	1
9.1949-S	1.109.870	Retentor Eixo BBA Injetora	1
9.2069-S	275.591	Retentor Dianteiro do Virabrequim	1
9.2235-S	231.938	Retentor Traseiro do Virabrequim	1

TODAS AS PEÇAS SÃO FORNECIDAS INDIVIDUALMENTE

LK 140 / 141 – LKS 140

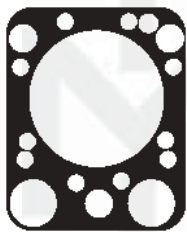

59.801-OIL

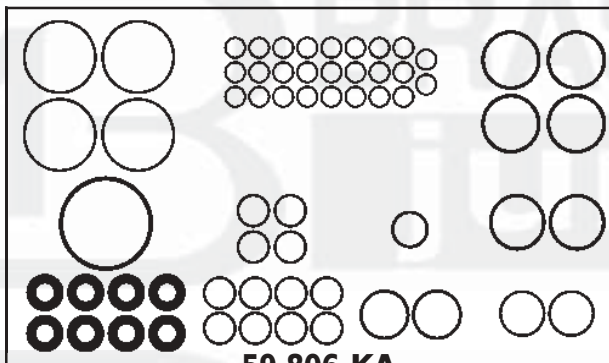

59.806-KA

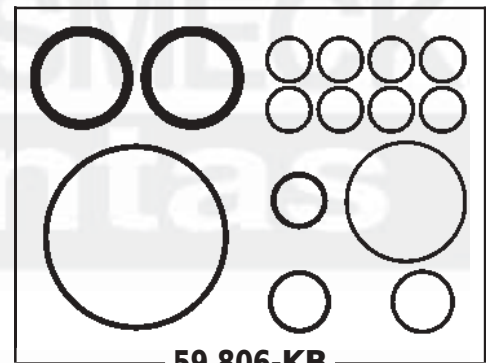

59.806-KB

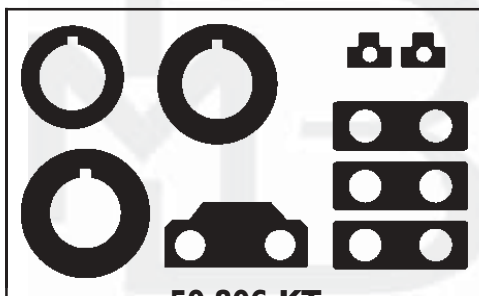

59.806-KT

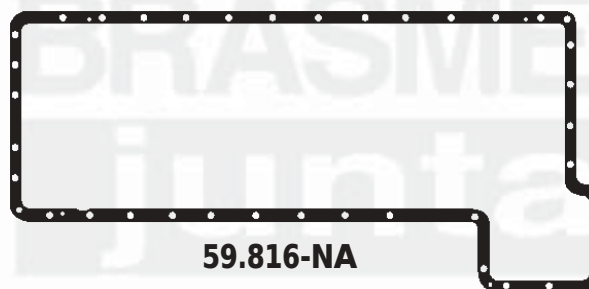

59.816-NA



59.821-BBS



59.822-BBS



59.823-BBS



59.826-BO



59.827-GV



59.828-NA



59.829-NA

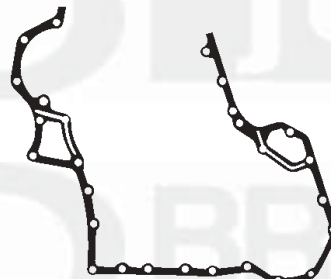

59.830-NA

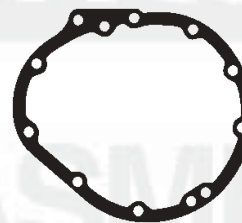

59.831-NA



59.832-GV



59.833-NA

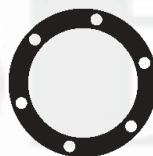

59.834-NA



59.835-NA



59.836-GV



59.837-NA



59.838-GV



59.839-GV



59.840-GV



59.841-GV



59.842-GV



59.843-GV



59.844-GV



59.845-NA



59.846-GV



59.847-NA



59.848-NA

Scania DSC 124 – Motor 360



59.102-OIL



59.031-NA



59.036-NA



59.076-NA



59.093-BO



59.094-BO

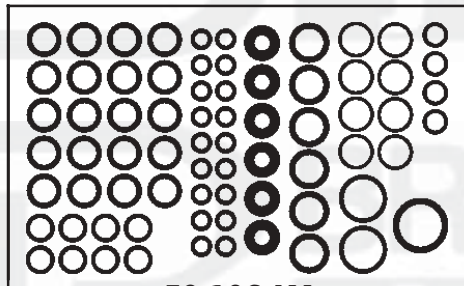

59.106-KA

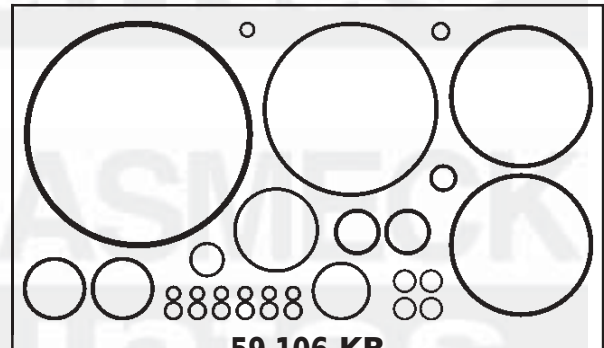

59.106-KB



59.116-NA



59.125-BO



59.126-BO



59.128-NA

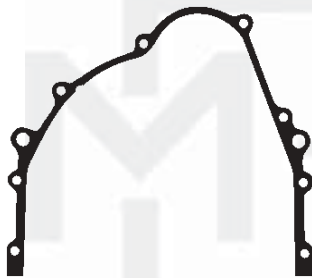

59.129-NA



59.133-NA



59.135-NA



59.142-NA



59.145-NA

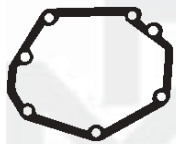

59.187-NA

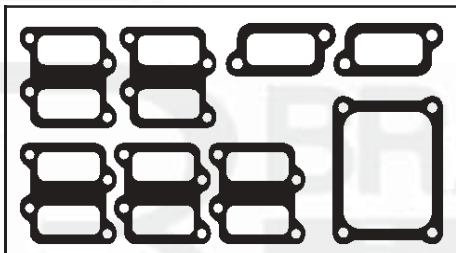

59.220-NA

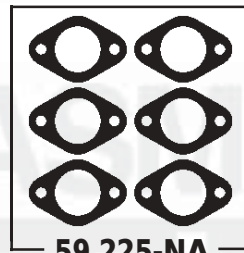

59.225-NA



59.230-NA



59.231-BO



59.232-NA



59.235-BO

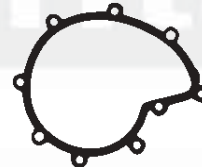

59.237-NA



59.241-NA

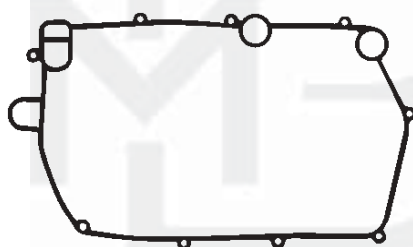

59.242-BO



59.243-BO



59.246-AL



59.247-BO

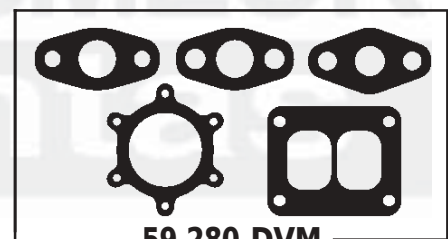

59.280-DVM

L-75 / 76 / 110 – Motor Nacional Ônibus / Caminhão (63/76)



59.601-OIL

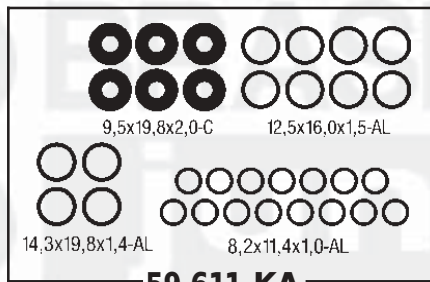

59.611-KA

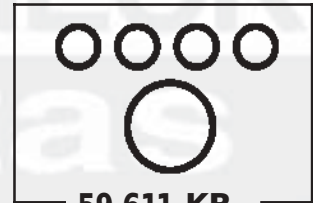

59.611-KB



59.626-CB



59.627-NA



59.635-GV



59.639-PS



59.640-GV



59.643-NA



59.644-NA



59.646-NA



59.721-CHAC



59.722-CHAC

DESENHOS FORA DE ESCALA

CÓDIGO BRASMECK	CÓDIGO ORIGINAL	DESCRIÇÃO	QTDE.
59.611-C	750.008	Jogo de Juntas para Retificação de Válvulas c/ Cabeçote	
59.611-S		Jogo de Juntas para Retificação de Válvulas s/ Cabeçote	
59.601-OIL	271.980	Junta do Cabeçote	2
59.611-KA		Kit de Arruelas	1
59.611-KB		Kit de Borrachas	1
59.626-CB	258.459	Junta da Tampa de Válvulas	2
59.627-NA	277.632	Junta do Coletor de Admissão	2
59.635-GV	139.108	Junta do Coletor de Admissão	2
59.639-PS	139.123	Junta do Suporte do Balanceiro	6
59.640-GV	139.044	Junta do Termostato	2
59.643-NA	152.667	Junta do Coletor de Escape	2
59.644-NA	291.826	Junta do Termostato	2
59.646-NA	278.602	Junta da Passagem D'Água	1
59.721-CHAC	277.272	Junta do Escape.	2
59.722-CHAC	277.273	Junta do Escape.	2

TODAS AS PEÇAS SÃO FORNECIDAS INDIVIDUALMENTE

L-111 / L-112 Ônibus B-76 (76/89)



59.701-OIL



59.626-CB



59.627-NA



59.639-PS



59.640-GV



59.644-NA



59.646-NA

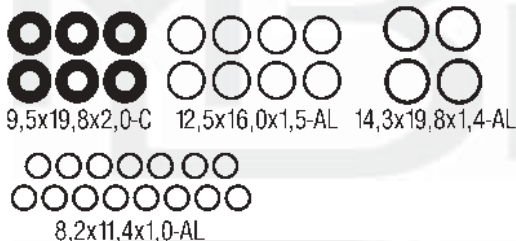

59.711-KA

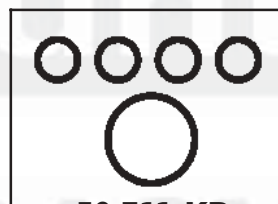

59.711-KB



59.721-CHAC



59.722-CHAC



59.731-NA



59.735-GV



59.756-GV

DESENHOS FORA DE ESCALA

CÓDIGO BRASMECK	CÓDIGO ORIGINAL	DESCRIÇÃO	QTDE.
59.711-C	750.008	Jogo de Juntas para Retificação de Válvulas c/ Cabeçote	
59.711-S		Jogo de Juntas para Retificação de Válvulas s/ Cabeçote	
59.701-OIL	271.980	Junta do Cabeçote	2
59.626-CB	258.459	Junta da Tampa de Válvulas	2
59.627-NA	277.632	Junta Coletor Admissão	2
59.639-PS	139.123	Junta do Suporte do Balanceiro	6
59.640-GV	139.044	Junta do Termostato	1
59.644-NA	291.826	Junta do Termostato	2
59.646-NA	278.602	Junta da Passagem D'Água	1
59.711-KA		Kit Arruelas	1
59.711-KB		Kit Anéis de Borracha	1
59.721-CHAC	277.272	Junta do Escape.	2
59.722-CHAC	277.273	Junta do Escape.	2
59.731-NA	183.938	Junta do Cano de Escape.	1
59.735-GV	238.148	Junta do Termostato	1
59.756-GV	277.637	Junta do Abafador	1

TODAS AS PEÇAS SÃO FORNECIDAS INDIVIDUALMENTE

HW 112/113 – DN / DS / DSC11 (82/...)



59.701-OIL



59.521-NA



59.522-NA



59.624-NA



59.626-CB



59.627-NA



59.644-NA



59.646-NA



59.655-NA

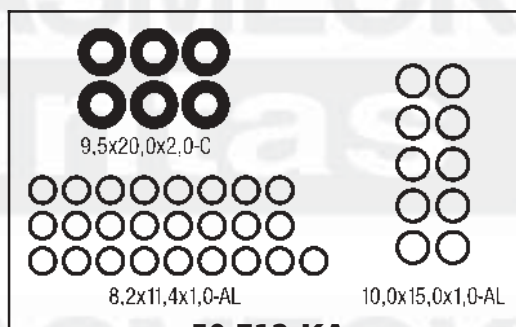

59.712-KA

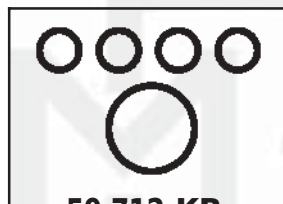

59.712-KB



59.720-BBS



59.724-BBS



59.756-GV

DESENHOS FORA DE ESCALA

CÓDIGO BRASMECK	CÓDIGO ORIGINAL	DESCRIÇÃO	QTDE.
59.712-C	750.008	Jogo de Juntas para Retificação de Válvulas c/ Cabeçote	
59.712-S		Jogo de Juntas para Retificação de Válvulas s/ Cabeçote	
59.701-OIL	271.980	Junta do Cabeçote	2
59.521-NA	1.675.583-B	Junta da Admissão	4
59.522-NA	1.675.584-B	Junta da Admissão	2
59.624-NA	338.332	Junta da Admissão	1
59.626-CB	258.459	Junta da Tampa de Válvulas	2
59.627-NA	277.632	Junta do Coletor de Admissão	2
59.644-NA	291.826	Junta do Termostato	2
59.646-NA	278.602	Junta da Passagem D'Água	1
59.655-NA	287.789	Junta Tubo Saída do Escape	1
59.692-NA	141.920	Junta do Corpo do Compressor	1
59.712-KA		Kit de Arruelas	1
59.712-KB		Kit Anéis de Borracha	1
59.720-BBS	1.109.288	Junta do Coletor	2
59.724-BBS	378.264	Junta do Coletor	2
59.756-GV	277.637	Junta do Abafador	1

TODAS AS PEÇAS SÃO FORNECIDAS INDIVIDUALMENTE

Scania HW 1990



59.701-OIL



59.624-NA



59.626-CB



59.627-NA



59.644-NA



59.646-NA

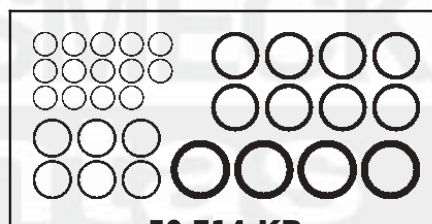

59.714-KR



59.733-GV



59.720-BBS



59.724-BBS



59.935-GV

DESENHOS FORA DE ESCALA

CÓDIGO BRASMECK	CÓDIGO ORIGINAL	DESCRIÇÃO	QTDE.
59.714-C	750.008	Jogo de Juntas para Retificação de Válvulas c/ Cabeçote	
59.714-S		Jogo de Juntas para Retificação de Válvulas s/ Cabeçote	
59.701-OIL	271.980	Junta do Cabeçote	2
59.624-NA	338.332	Junta da Admissão	1
59.626-CB	258.459	Junta da Tampa de Válvulas	2
59.627-NA	277.632	Junta do Coletor de Admissão	2
59.644-NA	291.826	Junta do Termostato	2
59.646-NA	278.602	Junta da Passagem D'Água	1
59.714-KR		Kit de Reparo	1
59.733-GV	238.309	Junta do Abafador	1
59.720-BBS	1.109.288	Junta do Coletor	2
59.724-BBS	378.264	Junta do Coletor	2
59.935-GV	271.238	Junta	1

TODAS AS PEÇAS SÃO FORNECIDAS INDIVIDUALMENTE

LK-140 / 141 / LKS 140



59.801-OIL



59.821-BBS



59.826-BO



59.828-NA



59.832-NA



59.837-NA



59.839-GV



59.857-BO



59.863-BO

DESENHOS FORA DE ESCALA

CÓDIGO BRASMECK	CÓDIGO ORIGINAL	DESCRIÇÃO	QTDE.
59.811-C	750.008	Jogo de Juntas para Retificação de Válvulas c/ Cabeçote	
59.811-S		Jogo de Juntas para Retificação de Válvulas s/ Cabeçote	
59.801-OIL	170.274	Junta do Cabeçote	1
59.821-BBS	170.363	Junta do Escape.	1
59.826-BO	170.610	Junta da Tampa das Válvulas	1
59.828-NA	277.607	Junta do Coletor Admissão / Escape	1
59.832-NA	170.368	Junta do Cano D'Água	1
59.837-NA	170.627	Junta Lateral do Cabeçote	1
59.839-GV	170.675	Junta do Balancim do Mancal	2
59.857-BO		Anel de Borracha 19x22x1,5mm	1
59.863-BO		Anel de Borracha 20x28x4,0mm	1

TODAS AS PEÇAS SÃO FORNECIDAS INDIVIDUALMENTE

Scania DSC 124 Motor 360

59.102-OIL

59.125-BO

59.126-BO

59.223-NA

59.229-NA

59.597-BO

59.598-AL

59.599-CU

DESENHOS FORA DE ESCALA

CÓDIGO BRASMECK	CÓDIGO ORIGINAL	DESCRIÇÃO	QTDE.
59.111-C	750.008	Jogo de Juntas para Retificação de Válvulas c/ Cabeçote Para 1 cil	
59.111-S		Jogo de Juntas para Retificação de Válvulas s/ Cabeçote Para 1 cil	
59.102-OIL	551.363	Junta do Cabeçote	1
59.125-BO	1.367.027	Junta da Tampa das Válvulas	1
59.126-BO	1.367.028	Junta da Tampa das Válvulas	1
59.223-NA	1.373.340	Junta do Coletor de Admissão	1
59.229-NA	1.309.051	Junta do Escape.	1
59.597-BO		Anel de Borracha 23x19x1.8mm	3
59.599-CU		Arruela de Cobre 20x9.4x2.0mm	1
59.598-AL		Arruela 13x8x1.8mm	6

TODAS AS PEÇAS SÃO FORNECIDAS INDIVIDUALMENTE

Scania DSC 124 Motor 420

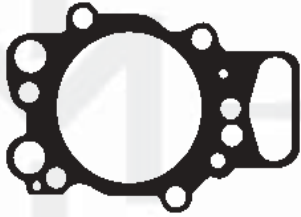

59.102-OIL



59.221-BBS



59.222-NA



59.223-NA



59.226-BO



59.227-BO



59.229-NA



59.597-BO



59.598-AL



59.599-CU

DESENHOS FORA DE ESCALA

CÓDIGO BRASMECK	CÓDIGO ORIGINAL	DESCRIÇÃO	QTDE.
59.112-C	750.008	Jogo de Juntas para Retificação de Válvulas c/ Cabeçote Para 1 cil	
59.112-S		Jogo de Juntas para Retificação de Válvulas s/ Cabeçote Para 1 cil	
59.102-OIL	551.363	Junta do Cabeçote	1
59.221-BBS	1.309.051	Junta do Coletor de Escape.	1
59.222-NA	1.374.338	Junta do Coletor de Admissão	1
59.223-NA	1.374.340	Junta do Coletor de Admissão	1
59.226-BO	1.401.982	Junta da Tampa das Válvulas Superior	1
59.227-BO	1.414.422	Junta da Tampa das Válvulas Inferior	1
59.229-NA	1.401.982	Junta do Escape.	1
59.597-BO		Anel de Borracha 23x19x1.8mm	3
59.599-CU		Arruela de Cobre 20x9.4x2.0mm	1
59.598-AL		Arruela 13x8x1.8mm	6

TODAS AS PEÇAS SÃO FORNECIDAS INDIVIDUALMENTE

GR / GRS / RE 890 / 900 – 8 Marchas

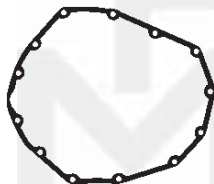

59.181-NA

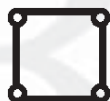

59.183-NA



59.184-NA



59.186-NA



59.188-BO



59.189-BO



59.387-PS

DESENHOS FORA DE ESCALA

CÓDIGO BRASMECK	CÓDIGO ORIGINAL	DESCRIÇÃO	QTDE.
59.180-NA	550.539	Jogo de Juntas do Cambio	
59.181-NA	1.305.139	Junta da Tampa Reduzida	1
59.183-NA	1.305.673	Junta da Tampa Superior	1
59.184-NA	1.329.585	Junta da Tampa Superior	1
59.186-NA	1.302.556	Junta da Tampa Lateral	1
59.188-BO	804.660	Anel de Borracha	1
59.189-BO	810.958	Anel de Borracha	1
59.387-PS	224.915	Junta da Tampa Inferior	1

TODAS AS PEÇAS SÃO FORNECIDAS INDIVIDUALMENTE

GR 801 – 8 Marchas (Ônibus)

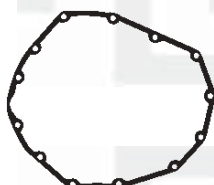

59.181-NA

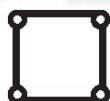

59.183-NA



59.191-NA



59.186-NA



59.188-BO



59.189-BO



59.387-PS

DESENHOS FORA DE ESCALA

CÓDIGO BRASMECK	CÓDIGO ORIGINAL	DESCRIÇÃO	QTDE.
59.190-NA	550.540	Jogo de Juntas do Cambio	
59.181-NA	1.305.139	Junta da Tampa Reduzida	1
59.183-NA	1.305.673	Junta da Tampa Superior	1
59.186-NA	1.302.556	Junta da Tampa Lateral	1
59.191-NA	1.329.586	Junta da Tampa Superior da Caixa	1
59.188-BO	804.660	Anel de Borracha	1
59.189-BO	810.958	Anel de Borracha	1
59.387-PS	224.915	Junta da Tampa Inferior	1

TODAS AS PEÇAS SÃO FORNECIDAS INDIVIDUALMENTE

L-110 / 111 – LK 140 / 141 (Caminhão) Caixa GR 860 10 Marchas (com anéis)

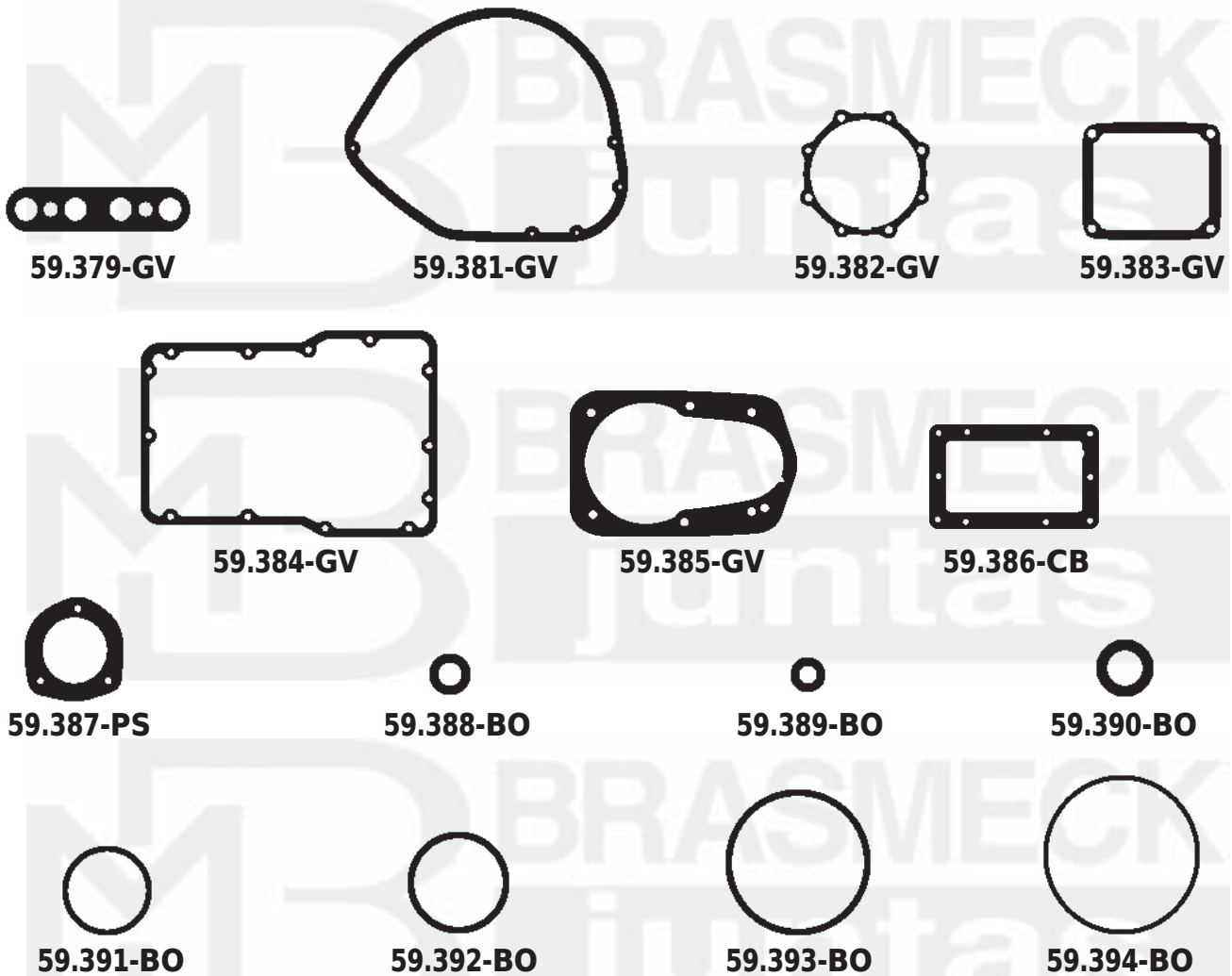

DESENHOS FORA DE ESCALA

CÓDIGO BRASMECK	CÓDIGO ORIGINAL	DESCRIÇÃO	QTDE.
59.380-GV	550.514/X	Jogo de Juntas do Cambio	
59.379-GV	35.737	Junta do Câmbio	1
59.381-GV	194.515	Junta Reduzida	1
59.382-GV	214.747	Junta da Tampa Traseira	2
59.383-GV	194.489	Junta da Alavanca	1
59.384-GV	194.488	Junta da Tampa do Câmbio	1
59.385-GV	254.042	Junta da Carcaça	1
59.386-CB	164.061	Junta da Caixa Reduzida Moderna	1
59.387-PS	224.915	Junta da Tampa Inferior	1
59.388-BO	810.962	Anéis de Borracha	2
59.389-BO	810.967	Anel de Borracha	1
59.390-BO	810.968	Anel de Borracha	1
59.391-BO	811.045	Anel de Borracha	1
59.392-BO	810.983	Anel de Borracha	1
59.393-BO	810.993	Anel de Borracha	1
59.394-BO	194.414	Anel de Borracha Moringa	2

TODAS AS PEÇAS SÃO FORNECIDAS INDIVIDUALMENTE

DESENHOS FORA DE ESCALA

B-111 / BR 112 / K 111 / K-S 112 (Ônibus)



59.383-NA

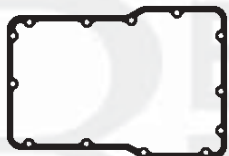

59.384-GV



59.387-PS



59.394-BO



59.395-GV



59.481-GV



59.482-GV

CÓDIGO BRASMECK	CÓDIGO ORIGINAL	DESCRIÇÃO	QTDE.
59.480-GV	550.514/X	Jogo de Juntas do Cambio	
59.383-NA	194.489	Junta da Tampa da Alavanca	1
59.384-GV	194.488	Junta da Tampa do Câmbio	1
59.387-PS	224.915	Junta da Tampa Inferior	1
59.394-BO	194.414	Anel de Borracha da Moringa	1
59.395-GV	304.061	Junta da Caixa de Transmissão	1
59.481-GV	294.361	Junta do Câmbio	1
59.482-GV	294.320	Junta do Câmbio	1

TODAS AS PEÇAS SÃO FORNECIDAS INDIVIDUALMENTE

DESENHOS FORA DE ESCALA

B-75 / 76 (Ônibus)



59.386-CB



59.775-GV



59.785-GV



59.787-GV



59.793-GV



59.794-GV



59.795-GV

CÓDIGO BRASMECK	CÓDIGO ORIGINAL	DESCRIÇÃO	QTDE.
59.780-GV	750.504	Jogo de Juntas do Cambio	
59.386-CB	164.061	Junta da Caixa Reduzida Moderna	1
59.775-GV	35.737	Junta da Capa da Alavanca	1
59.785-GV	35.638	Junta da Moringa	1
59.787-GV	35.743	Junta Lateral da Carcaça	1
59.793-GV	164.716	Junta Traseira Caixa Embreagem	1
59.794-GV	35.740	Junta Tampa Superior do Câmbio	1
59.795-GV	35.738	Junta da Carcaça da Embreagem	1

TODAS AS PEÇAS SÃO FORNECIDAS INDIVIDUALMENTE

DESENHOS FORA DE ESCALA

Scania L-75



59.770-GV

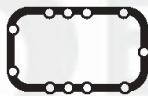

59.771-GV



59.772-GV



59.773-GV



59.774-GV



59.775-GV



59.776-GV

CÓDIGO BRASMECK	CÓDIGO ORIGINAL	DESCRIÇÃO	QTDE.
59.781-GV	750.505	Jogo de Juntas do Cambio	
59.770-GV	124.598	Junta da Tampa Traseira	1
59.771-GV	123.856	Junta Lateral da Caixa Reduzida	1
59.772-GV	123.845	Junta da Tampa da Caixa	1
59.773-GV	123.843	Junta da Luva Superior Mancal Rolamento	1
59.774-GV	123.857	Junta da Carcaça Embreagem Caixa Mudança	1
59.775-GV	35.737	Junta da Capa da Alavanca	1
59.776-GV	124.599	Junta da Tampa Contra Eixo Câmbio	1

TODAS AS PEÇAS SÃO FORNECIDAS INDIVIDUALMENTE

DESENHOS FORA DE ESCALA

Scania L-75 (Caixa Reduzida)



59.652-BO



59.760-GV



59.761-GV



59.762-GV



59.763-GV

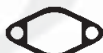

59.764-GV



59.765-CB



59.767-BO

CÓDIGO BRASMECK	CÓDIGO ORIGINAL	DESCRIÇÃO	QTDE.
59.782-GV	750.556	Jogo de Juntas do Cambio	
59.652-BO	173.126	Anel de Borracha	1
59.760-GV	122.090	Junta do Conjunto das Árvores	3
59.761-GV	132.759	Junta da Cobertura da Árvore Intermediária	3
59.762-GV	132.757	Junta da Cobertura para Árvore Intermediária	1
59.763-GV	132.755	Junta da Cobertura da Árvore Primária	1
59.764-GV	132.764	Junta da Cobertura para Barra do Cabeçote	1
59.765-CB	132.753	Junta Tampa Inferior	1
59.767-BO	132.249	Anel de Borracha	1

TODAS AS PEÇAS SÃO FORNECIDAS INDIVIDUALMENTE

DESENHOS FORA DE ESCALA

Scania L-76 (Caixa Acoplada Moderna)



59.386-CB



59.759-GV



59.768-GV



59.769-GV



59.773-GV



59.774-GV



59.775-GV

CÓDIGO BRASMECK	CÓDIGO ORIGINAL	DESCRIÇÃO	QTDE.
59.783-GV	750.506	Jogo de Juntas do Cambio	
59.386-CB	164.061	Junta da Caixa Reduzida Moderna	1
59.759-GV	164.378	Junta da Tampa da Caixa	1
59.768-GV		Junta da Tampa Dianteira	1
59.769-GV		Junta da Tampa Traseira	1
59.773-GV	123.843	Junta Luva Suporte Mancal de Rolamento	1
59.774-GV	123.857	Junta da Carcaça Embreagem Caixa de Mudança	1
59.775-GV	35.737	Junta da Capa da Alavanca	1

TODAS AS PEÇAS SÃO FORNECIDAS INDIVIDUALMENTE

DESENHOS FORA DE ESCALA

SC B-110 / 111 – BR 115/116 (Ônibus Motor Dianteiro)



59.383-GV

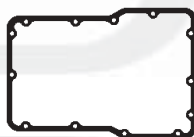

59.384-GV



59.386-CB



59.387-PS



59.394-BO



59.877-GV



59.878-GV



59.879-GV



71.654-BO

CÓDIGO BRASMECK	CÓDIGO ORIGINAL	DESCRIÇÃO	QTDE.
59.881-GV	550.510	Jogo de Juntas do Cambio	
59.383-GV	194.489	Junta da Alavanca	1
59.384-GV	194.488	Junta da Tampa do Câmbio	1
59.386-CB	164.061	Junta da Caixa Reduzida Moderna	1
59.387-PS	224.915	Junta da Tampa Inferior	1
59.394-BO	194.414	Anel de Borracha da Moringa	1
59.877-GV	224.894	Junta do Câmbio	1
59.878-GV	194.584	Junta da Alavanca	1
59.879-GV	194.583	Junta do Câmbio	1
71.654-BO	234.031	Anel de Borracha	1

TODAS AS PEÇAS SÃO FORNECIDAS INDIVIDUALMENTE

DESENHOS FORA DE ESCALA

Compressor de Ar Bendix TU-FLU 500



50.272-NA



50.274-NA



50.275-NA



50.276-NA



50.277-NA



59.688-NA



59.691-NA

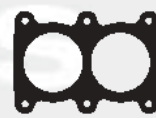

59.692-NA

CÓDIGO BRASMECK	CÓDIGO ORIGINAL	DESCRIÇÃO	QTDE.
50.260-NA		Jogo de Juntas do Compressor de Ar Bendix TU-FLU 500	
50.272-NA	9610/54497	Junta do Compressor	2
50.274-NA	9610/54498	Junta do Compressor	1
50.275-NA	9610/54479	Junta do Compressor	1
50.276-NA	251.207	Junta do Compressor	1
50.277-NA	307.221	Junta do Compressor	1
59.688-NA	148.090	Junta do Compressor	1
59.691-NA	141.926	Junta do Compressor	1
59.692-NA	141.920	Junta do Corpo do Compressor	1

TODAS AS PEÇAS SÃO FORNECIDAS INDIVIDUALMENTE

DESENHOS FORA DE ESCALA

Compressor de Ar Bendix TU-FLU 700



50.272-NA



50.273-NA

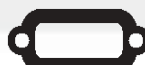

50.274-NA



50.275-NA



50.276-NA



50.277-NA



59.691-NA



59.692-NA

CÓDIGO BRASMECK	CÓDIGO ORIGINAL	DESCRIÇÃO	QTDE.
50.270-NA		Jogo de Juntas do Compressor de Ar Bendix TU-FLU 700	
50.272-NA	9610/54497	Junta do Compressor	2
50.273-NA	148.926.SSB	Junta do Cilindro	1
50.274-NA	9610/54498	Junta do Compressor	1
50.275-NA	9610/54479	Junta do Compressor	1
50.276-NA	251.207	Junta do Compressor	1
50.277-NA	307.221	Junta do Compressor	1
59.691-NA	141.926	Junta do Compressor	1
59.692-NA	141.920	Junta do Corpo do Compressor	1

TODAS AS PEÇAS SÃO FORNECIDAS INDIVIDUALMENTE

DESENHOS FORA DE ESCALA

Compressor Varga 2 cils



59.006-NA



59.011-NA



59.101-NA



59.103-NA



59.104-NA



59.105-NA



59.107-NA



59.108-NA



59.109-NA

CÓDIGO BRASMECK	CÓDIGO ORIGINAL	DESCRIÇÃO	QTDE.
59.100-NA	522.393	Jogo de Juntas do Compressor Varga 2 cils	
59.006-NA		Junta Conexão de Desgarga	1
59.011-NA		Junta da Tampa do Cabeçote	1
59.101-NA		Junta do Compressor	1
59.103-NA		Junta do Bloco	1
59.104-NA		Junta entre Bloco e Cabeçote	1
59.105-NA		Junta do Compressor	1
59.107-NA		Junta Fixação ao Cabeçote	1
59.108-NA		Junta do Coletor Entrada de Ar	1
59.109-NA		Junta da Tampa Dianteira	2

TODAS AS PEÇAS SÃO FORNECIDAS INDIVIDUALMENTE

DESENHOS FORA DE ESCALA

Compressor Varga 2 cils



59.001-NA



59.006-NA



59.011-NA



59.101-NA



59.103-NA



59.104-NA



59.105-NA



59.107-NA



59.108-NA



59.109-NA

CÓDIGO BRASMECK	CÓDIGO ORIGINAL	DESCRIÇÃO	QTDE.
59.110-NA		Jogo de Juntas do Compressor Varga 2 cils	
59.001-NA		Junta do Compressor	1
59.006-NA		Junta Conexão de Desgarga	1
59.011-NA		Junta da Tampa do Cabeçote	1
59.101-NA		Junta do Compressor	1
59.103-NA		Junta do Bloco	1
59.104-NA		Junta entre Bloco e Cabeçote	1
59.105-NA		Junta do Compressor	1
59.107-NA		Junta Fixação ao Cabeçote	1
59.108-NA		Junta do Coletor Entrada de Ar	1
59.109-NA		Junta da Tampa Dianteira	2

TODAS AS PEÇAS SÃO FORNECIDAS INDIVIDUALMENTE

DESENHOS FORA DE ESCALA

Turbina L-110 / 111 BR 116



59.265-NA



59.272-NA



59.273-CH



59.274-CH

CÓDIGO BRASMECK	CÓDIGO ORIGINAL	DESCRIÇÃO	QTDE.
59.260-DVM	222.499-X	Jogo de Juntas da Turbina L-110 / 111 BR 116	
59.265-NA	139.472	Junta do tubo de Drenagem da Turbina Inferior	1
59.272-NA	1.671.153	Junta da Saída do Compressor	1
59.273-CH	325.245/132.354	Junta da Mesa da Turbina	1
59.274-CH	365.863	Junta Entre Tubo e Cotovelo	1

TODAS AS PEÇAS SÃO FORNECIDAS INDIVIDUALMENTE

DESENHOS FORA DE ESCALA

Turbina T-112



59.263-CH



59.264-NA



59.265-NA



59.777-CHACH

CÓDIGO BRASMECK	CÓDIGO ORIGINAL	DESCRIÇÃO	QTDE.
59.270-DVM	365.863-X	Jogo de Juntas da Turbina T-112	
59.263-CH	222.499	Junta do Caracol da Turbina	1
59.264-NA	139.471	Junta do Tubo Lubrificador da Turbina Superior	1
59.265-NA	139.472	Junta do Tubo de Drenagem da Turbina Inferior	1
59.777-CHAC	139.616	Junta da Base da Turbina	1

TODAS AS PEÇAS SÃO FORNECIDAS INDIVIDUALMENTE

Escape. L-111/112 Ônibus B76



59.721-CHACH



59.722-CHACH

CÓDIGO BRASMECK	CÓDIGO ORIGINAL	DESCRIÇÃO	QTDE.
59.723-CHAC	139.616-X	Jogo de Juntas do Escape. L-111/112 Ônibus B76	
59.721-CHAC	277.272	Junta do Escape.	2
59.722-CHAC	277.273	Junta do Escape.	2

TODAS AS PEÇAS SÃO FORNECIDAS INDIVIDUALMENTE

Coletor do Escape. HW-112/113



59.720-BBS



59.724-BBS

CÓDIGO BRASMECK	CÓDIGO ORIGINAL	DESCRIÇÃO	QTDE.
59.825-BBS	378.264-X	Jogo de Juntas do Coletor do Escape. HW-112/113	
59.720-BBS	1.109.288	Junta do Coletor	2
59.724-BBS	378.264	Junta do Coletor	2

TODAS AS PEÇAS SÃO FORNECIDAS INDIVIDUALMENTE

Escape. LK 140/141



59.823-BBS

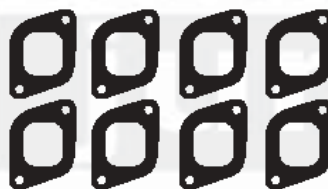

59.821-BBS

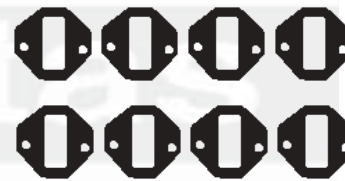

59.828-BBS

CÓDIGO BRASMECK	CÓDIGO ORIGINAL	DESCRIÇÃO	QTDE.
59.870-BBS		Jogo de Juntas do Escape. LK 140/141	
59.821-BBS	170.363	Junta do Escape.	8
59.823-BBS	170.932	Junta da Tubagem	2
59.828-GV	277.607	Junta do Coletor Admissão/Escape	8

TODAS AS PEÇAS SÃO FORNECIDAS INDIVIDUALMENTE

Coletor Admissão / Escape LK-140/141 - LKS-140



59.828-GV

DESENHOS FORA DE ESCALA

CÓDIGO BRASMECK	CÓDIGO ORIGINAL	DESCRIÇÃO	QTDE.
59.871-GV		Jogo de Juntas do Coletor Admissão / Escape LK-140/141 - LKS-140	
59.828-GV	277.607	Junta do Coletor Admissão / Escape	8

TODAS AS PEÇAS SÃO FORNECIDAS INDIVIDUALMENTE

Cano de Escape. LK-140/141 - LKS-140



59.832-GV

DESENHOS FORA DE ESCALA

CÓDIGO BRASMECK	CÓDIGO ORIGINAL	DESCRIÇÃO	QTDE.
59.873-GV		Jogo de Juntas do Cano de Escape. LK-140/141 - LKS-140	
59.832-GV	170.368	Junta do Cano de Escape.	8

TODAS AS PEÇAS SÃO FORNECIDAS INDIVIDUALMENTE

Escape. LK 140/141 - LKS-140



59.821-BBS

DESENHOS FORA DE ESCALA

CÓDIGO BRASMECK	CÓDIGO ORIGINAL	DESCRIÇÃO	QTDE.
59.875-BBS		Jogo de Juntas do Escape. LK-140/141 - LKS-140	
59.821-BBS	170.363	Junta do Escape.	8

TODAS AS PEÇAS SÃO FORNECIDAS INDIVIDUALMENTE

Admissão HW 112 / 113



59.521-NA



59.522-NA

DESENHOS FORA DE ESCALA

CÓDIGO BRASMECK	CÓDIGO ORIGINAL	DESCRIÇÃO	QTDE.
59.925-NA		Jogo de Juntas de Admissão HW 112 / 113	
59.521-NA	1.675.583-B	Junta da Admissão HW 112/113	4
59.522-NA	1.675.584-B	Junta da Admissão HW 112/113	2

TODAS AS PEÇAS SÃO FORNECIDAS INDIVIDUALMENTE

DESENHOS FORA DE ESCALA

CÓDIGO BRASMECK	CÓDIGO ORIGINAL	DESCRIÇÃO	QTDE.

TODAS AS PEÇAS SÃO FORNECIDAS INDIVIDUALMENTE

DESENHOS FORA DE ESCALA

CÓDIGO BRASMECK	CÓDIGO ORIGINAL	DESCRIÇÃO	QTDE.

TODAS AS PEÇAS SÃO FORNECIDAS INDIVIDUALMENTE



59.016-NA



59.021-CHA



59.022-NA



59.026-NA



59.027-CHA

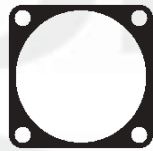

59.028-NA



59.030-NA

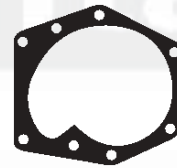

59.032-NA



59.033-NA



59.034-NA



59.035-NA



59.037-NA



59.038-NA



59.052-NA

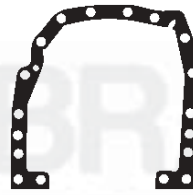

59.090-NA



59.091-NA



59.121-BBS



59.122-NA



59.124-NA



59.127-NA



59.131-NA



59.136-NA



59.155-NA



59.182-NA



59.185-NA



59.192-NA



59.233-BO

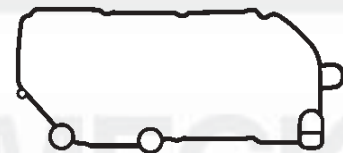

59.239-BO



59.248-CB



59.262-NA



59.266-NA



59.344-CB



59.345-CB



59.346-CB



59.376-NA



59.378-GV



59.397-NA



59.398-NA



59.487-GV



59.617-CB



59.618-CB

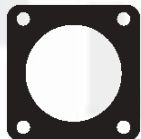

59.622-CHA



59.682-CB



59.687-GV



59.694-AL

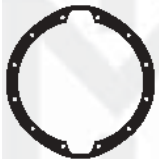

59.696-AL



59.717-CB



59.717-GV

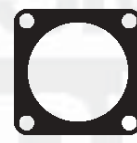

59.725-GV



59.777-CH



59.867-CB



59.868-CHA



59.892-GV



59.893-GV



59.894-NA



59.896-AL



59.943-NA



59.944-NA



59.966-CH



59.981-NA

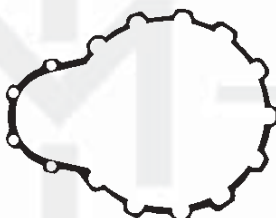

59.982-NA



59.983-NA



59.990-CH



59.994-CH

MB BRASMECK
juntas

MB BRASMECK
juntas

MB BRASMECK
juntas

MB BRASMECK
juntas

MB BRASMECK
juntas

MB BRASMECK
juntas

MB BRASMECK
juntas

MB BRASMECK
juntas

MB BRASMECK
juntas

MB BRASMECK
juntas

MB BRASMECK
juntas

MB BRASMECK
juntas

MB BRASMECK
juntas

MB BRASMECK
juntas

MB BRASMECK
juntas

MB BRASMECK
juntas

MB BRASMECK
juntas
TECNOLOGIA ORIGINAL EM PEÇAS DE REPOSIÇÃO

MB BRASMECK
juntas

Rua Alvares Cabral, 1.081 – CEP: 09980-160

Serraria - Diadema - SP

Fone: (0xx11) 4055-1111 - Fax: (0xx11) 4055-5522

Site: www.brasmeck.com.br

E-mail Dept. de Vendas: vendas@brasmeck.com.br

MB BRASMECK
juntas

MB BRASMECK
juntas

MB BRASMECK
juntas

MB BRASMECK
juntas

MB BRASMECK
juntas

MB BRASMECK
juntas

MB BRASMECK
juntas

MB BRASMECK
juntas

MB BRASMECK
juntas

MB BRASMECK
juntas

MB BRASMECK
juntas

MB BRASMECK
juntas

MB BRASMECK
juntas

MB BRASMECK
juntas

MB BRASMECK
juntas